

Interfacing TFT LCD Module ER-TFTM090-2 to MCU STC12LE5A60S2

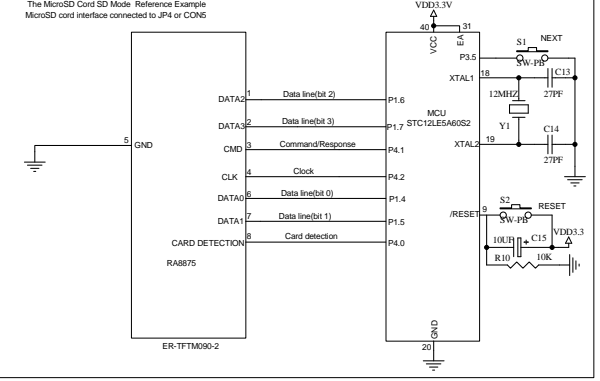
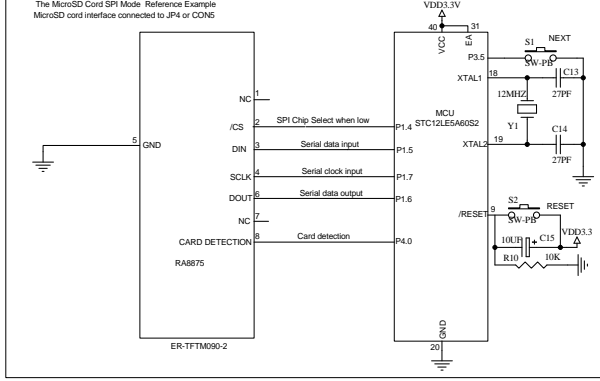
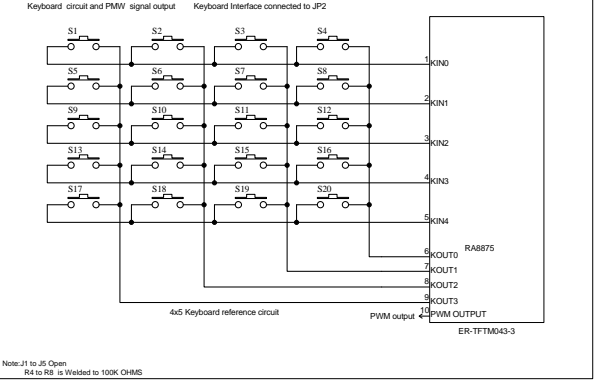
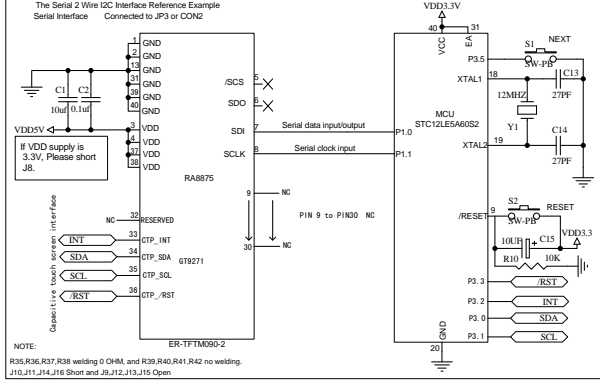
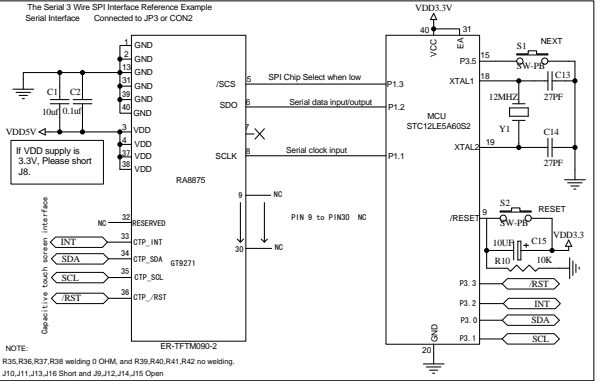
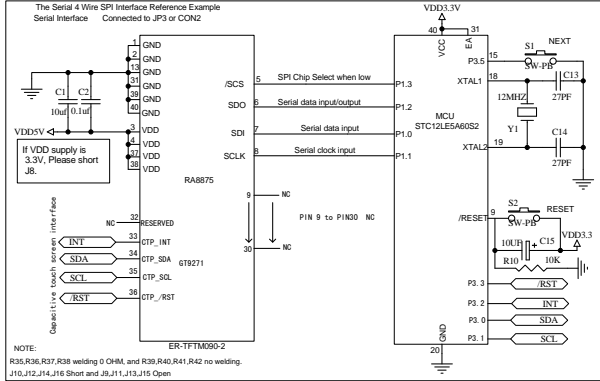
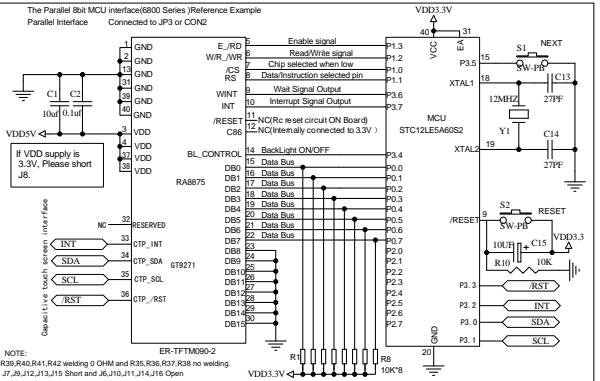
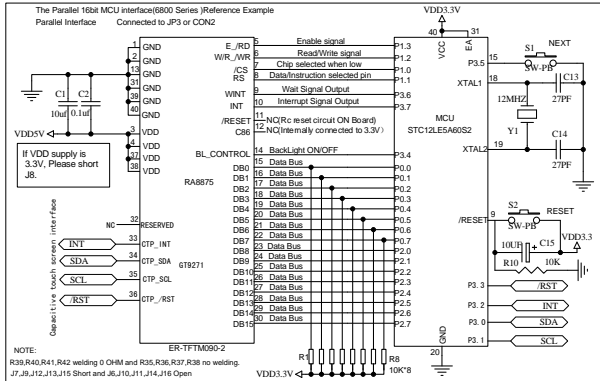
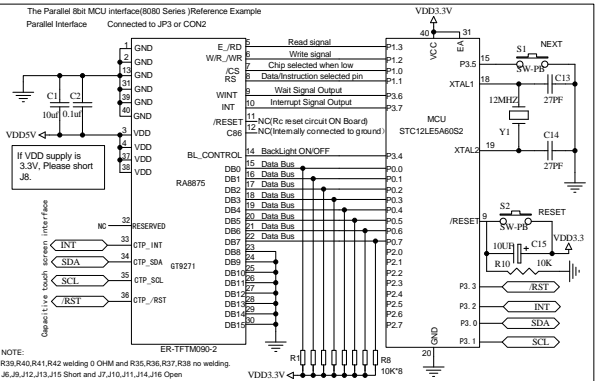
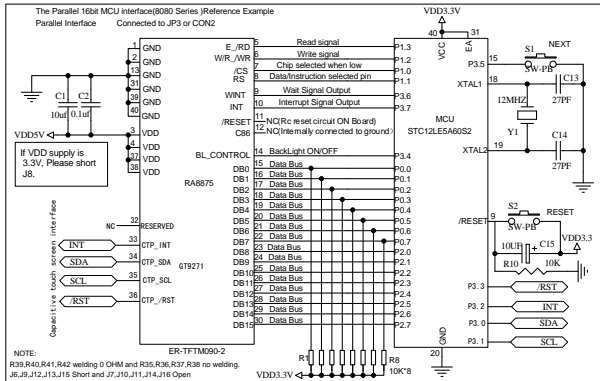

REV	DESCRIPTION OF MODIFY	MODIFY BY	DATE	Title	Size	Number	Revision
A0	I 'ST DESIGN	JIM	26-Jan-2015	EASTRISING TECHNOLOGY CO.,LTD.	A	ER-TFTM090-2	AO
A1	Add capacitive touch screen	JIM	27-May-2019				

Date: 26-Jan-2015
Sheet of 1
Drawn By JIM