

# Interfacing LCD Modules to the AT89LV52 MCU

The Parallel (8080 Series MCU Reference Example)

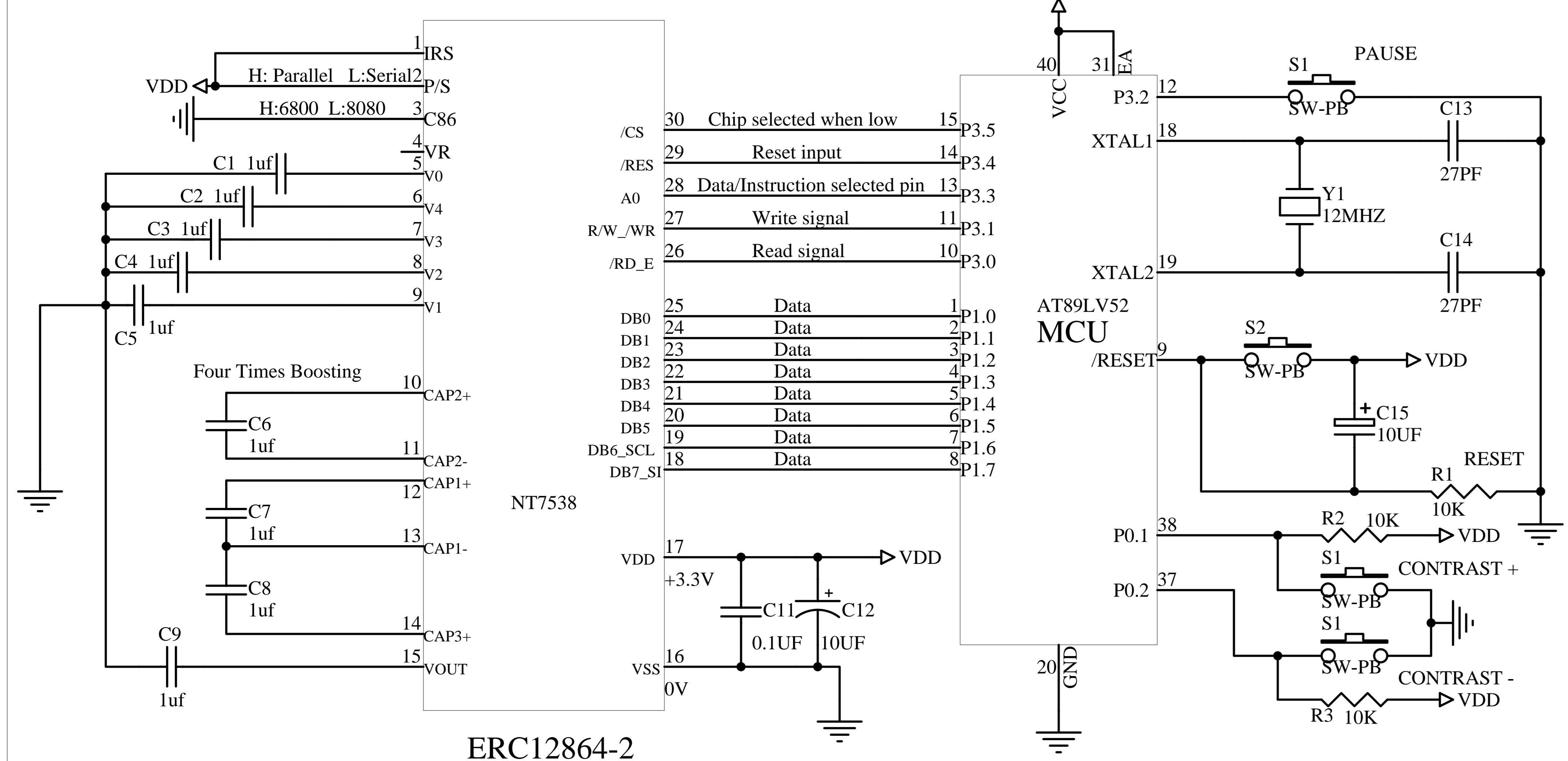

ERC12864-2

The Parallel (6800 Series MCU) Reference Example

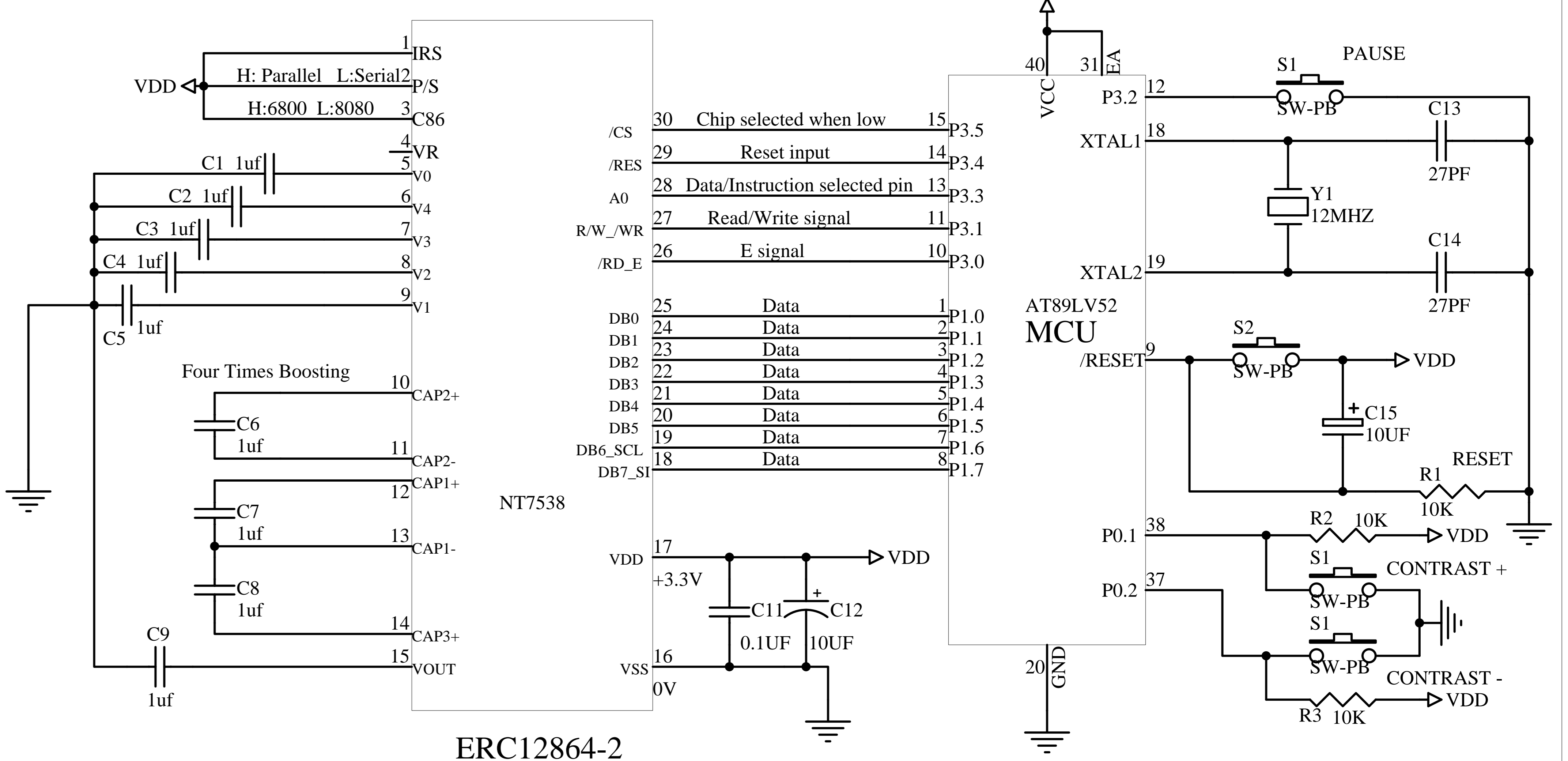

ERC12864-2

The Serial (SPI) Reference Example

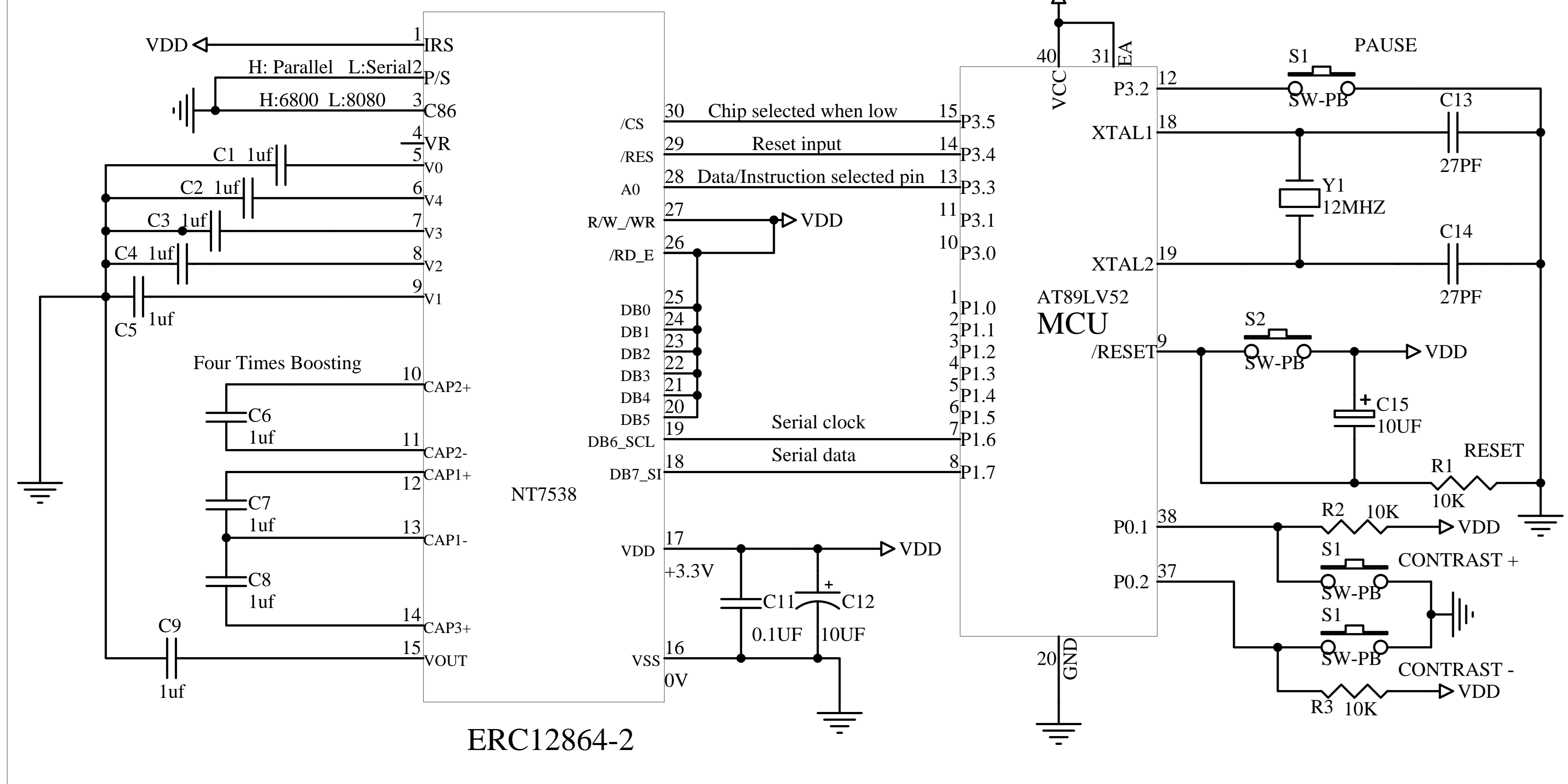

ERC12864-2

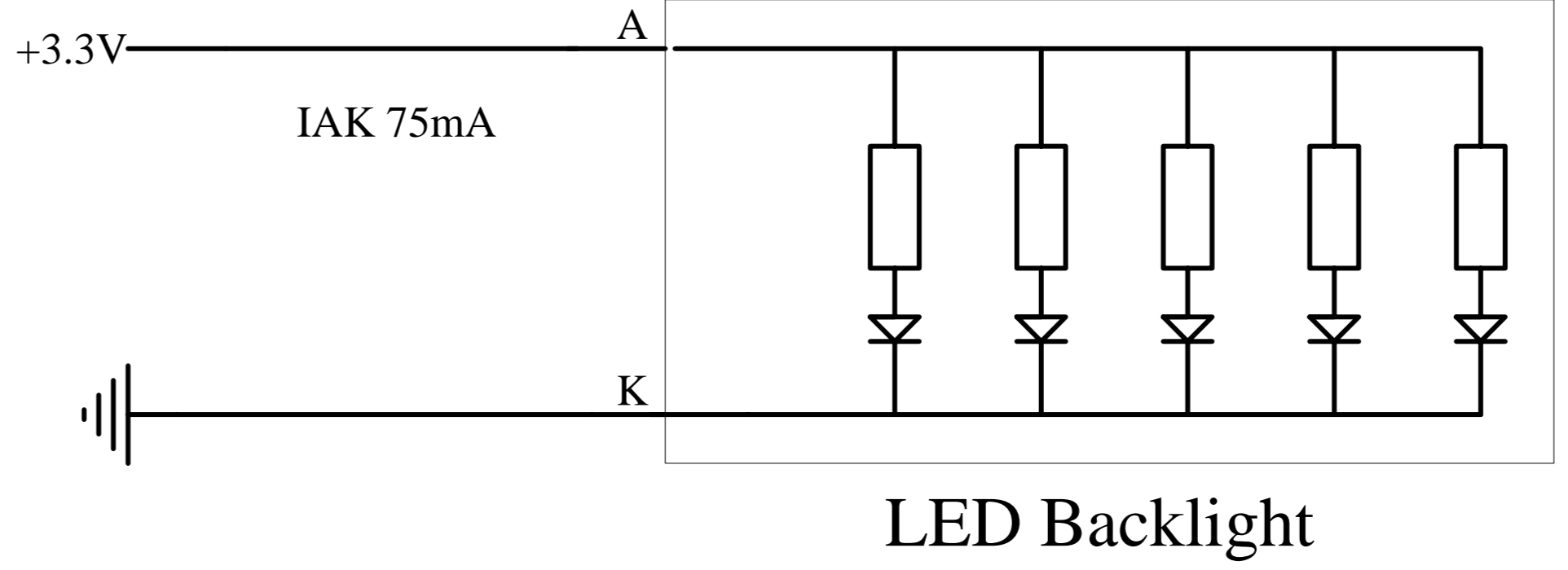

LED Backlight

Title			
<b>EASTRISING TECHNOLOGY CO.,LTD.</b>			
Size	Number	Revision	
A	ERC12864-2	A0	
Date:	19-Jun-2009	Sheet of	1
File		Drawn By	Javen