

Interfacing 4-wire SPI OLED Display Module to Raspberry pi

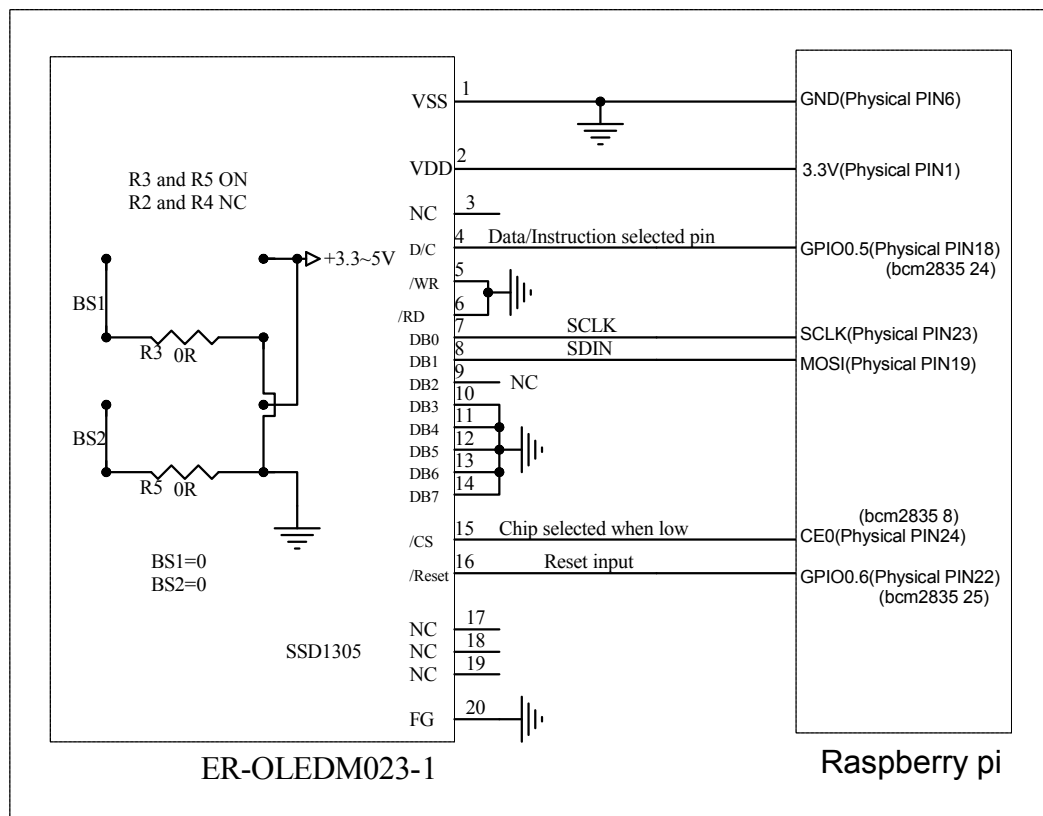

Interfacing 2-wire I2C OLED Display Module to Raspberry pi

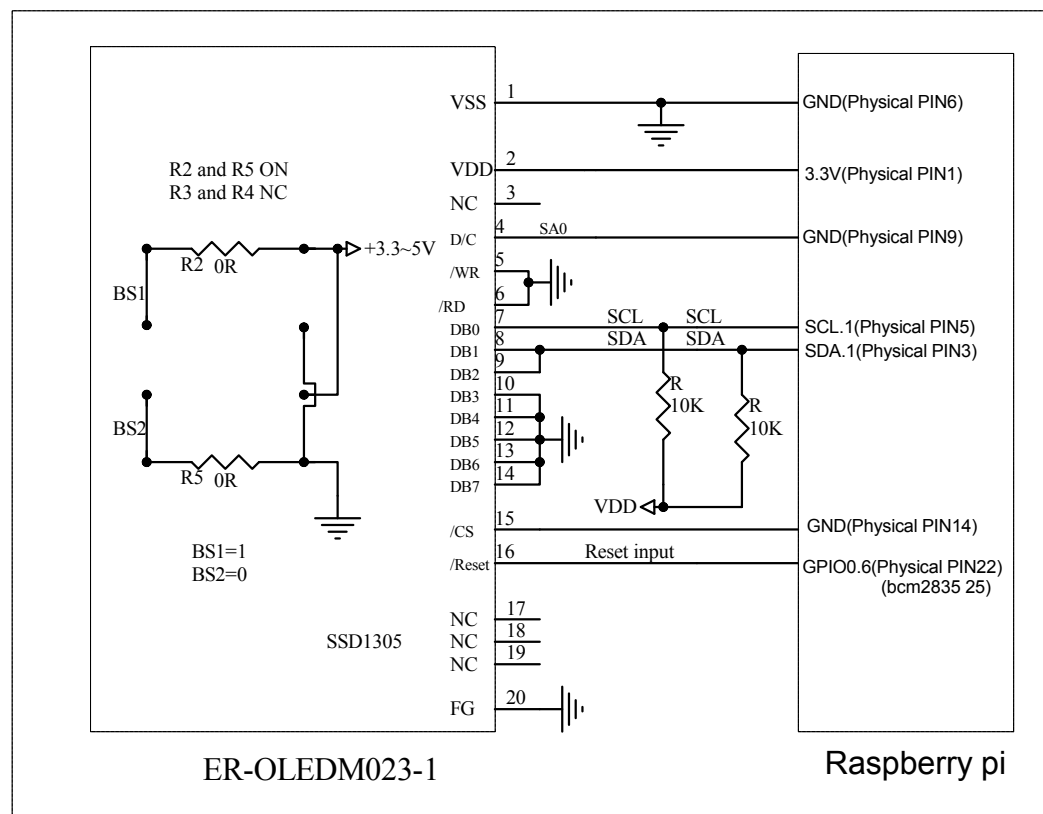

== How to use ==

1. Install the C libraries of bcm2835, see: <http://www.airspayce.com/mikem/bcm2835/>
2. Change the current directory to where the Makefile and oled.c file located.
3. Clean the file with: make clean
4. Compile the file with: make
5. Run the demo with: sudo ./oled

REV.	DESCRIPTION OF MODIFY	MODIFY BY	DATE
A0	1'ST DESIGN	JIM	29-Nov-2019
A1			

Title			
EASTRISING TECHNOLOGY CO.,LTD.			
Size	Number	Revision	
A	ER-OLEDM023-1 Series	A0	
Date:	29-Nov-2019	Sheet of	1
File		Drawn By	Javen