

Interfacing 4-wire SPI OLED Display Module to Raspberry pi

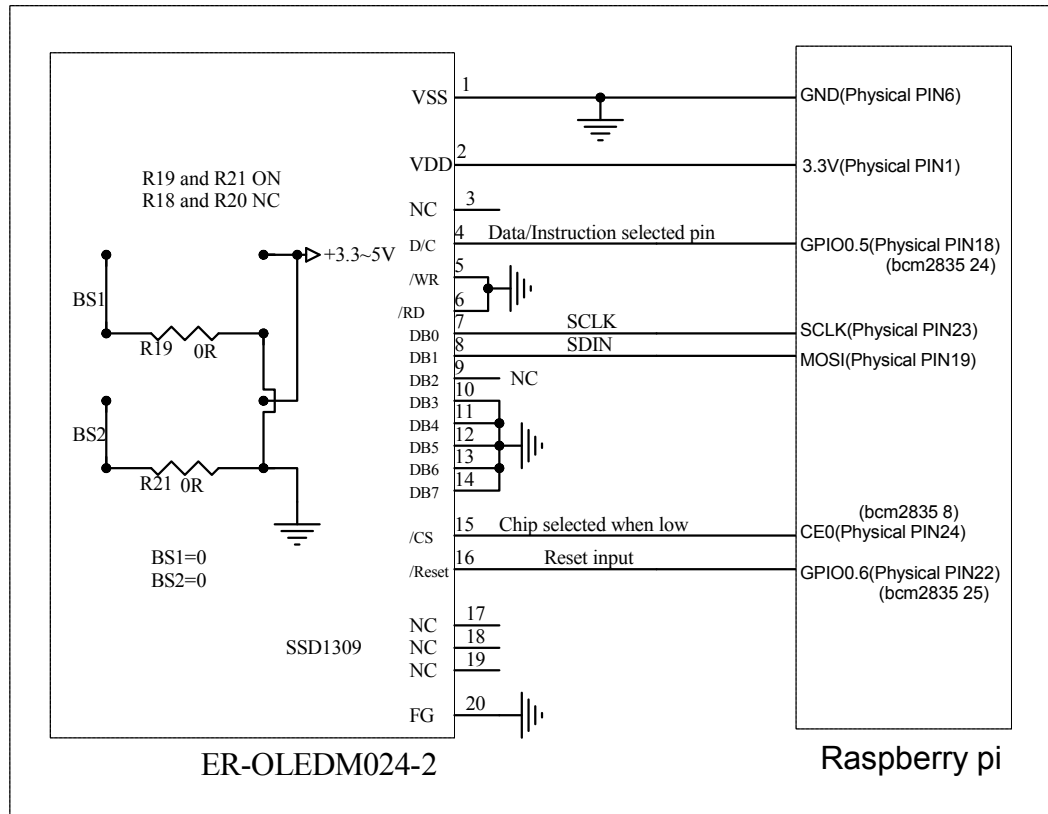

Interfacing 2-wire I2C OLED Display Module to Raspberry pi

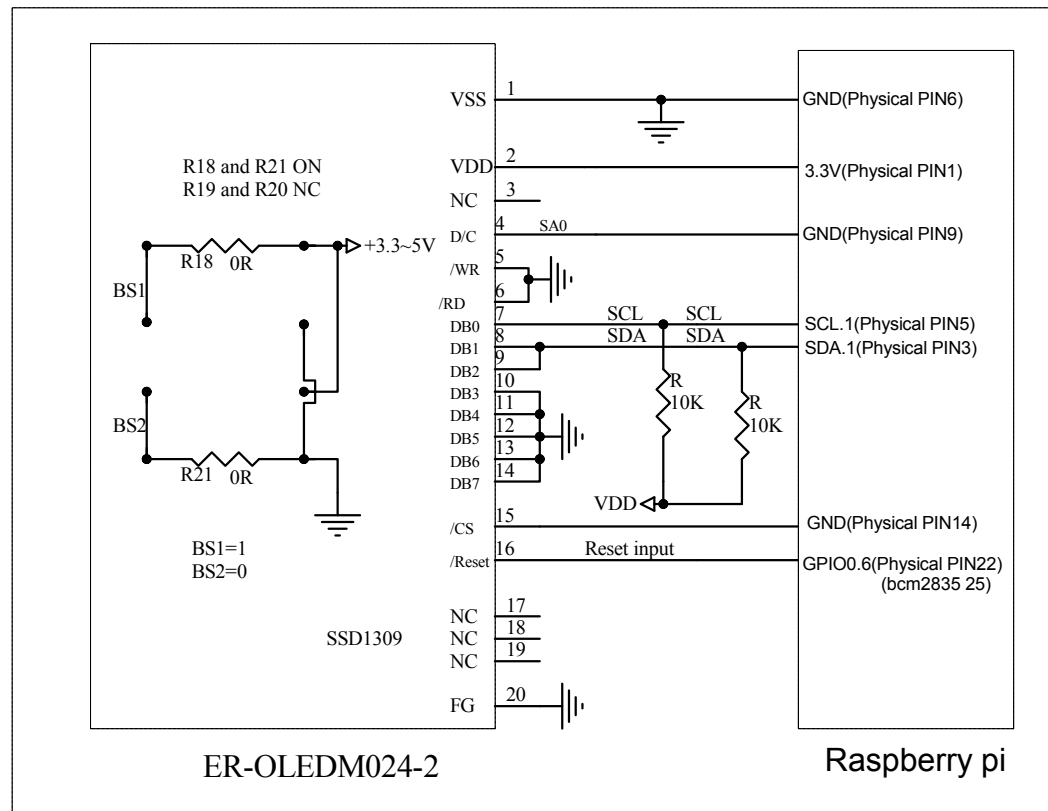

== How to use ==

- 1, Install the C libraries of bcm2835, see: <http://www.airspayce.com/mikem/bcm2835/>
- 2, Change the current directory to where the Makefile and oled.c file located.
- 3, Clean the file with: make clean
- 4, Compile the file with: make
- 5, Run the demo with: sudo ./oled

REV.	DESCRIPTION OF MODIFY	MODIFY BY	DATE
A0	1'ST DESIGN	JIM	29-Nov-2019
A1			

Title			
EASTRISING TECHNOLOGY CO.,LTD.			
Size	Number	Revision	
A	ER-OLEDM024-2 Series	A0	
Date:	29-Nov-2019	Sheet of	1
File		Drawn By	Javen