

L-WEA2010

Product Preview

454x454 TDDI for IOT/Wearable

This document contains information on a product under development. Solomon Systech reserves the right to change or discontinue this product without notice.

<http://www.solomon-systech.com>

L-WEA2010 | Rev 0.50 | P 1/73 | Apr 2021

Copyright © 2021 Solomon Systech Limited



APPENDIX: IC REVISION HISTORY OF L-WEA2010 SPECIFICATION

Version	Change Items	Effective Date
0.10	1 st Release	03-Nov-2020
0.20	Section 2, for Touch section, add I2C for communication with Host Section 7.6, update description of SPI pins Added Section 14 POWER ON/OFF SEQUENCE Added Section 15 OTP PROGRAM FLOW CHART Added Section 16 PACKAGE INFORMATION	26-Nov-2020
0.30	For Table 5.2 and section 7.2, Interface Selection, separated the pin definition of IM0 and IM1 to avoid confusion.	25-Jan-2021
0.40	Section 2, for MIPI section, removed Video mode	05-Feb-2021
0.50	Section 5, added die floor plan Section 6, added SPI/DSPI/QSPI timing, RAM block description Section 8, updated un-used pin setting Section 15, updated Power on/off sequence	23-Apr-2021

Confidential

CONTENTS

1	GENERAL DESCRIPTION	7
2	FEATURES	7
3	ORDERING INFORMATION	8
4	BLOCK DIAGRAM	9
5	DIE PAD FLOOR PLAN	10
6	BLOCK FUNCTION DESCRIPTION	11
6.1	MIPI INTERFACE	11
6.2	SYSTEM INTERFACE	11
6.2.1	4-wire SPI Timing	12
6.2.2	4-wire DSPI Timing	13
6.2.3	3-wire SPI Timing	14
6.2.4	QSPI Timing	15
6.3	REGULATOR / POWER GENERATION CIRCUIT	15
6.4	GIP DRIVING CIRCUITS	15
6.5	RAM	16
6.6	NON-VOLATILE MEMORY (NVM)	16
6.7	CLOCK GENERATION CIRCUIT	16
6.8	TOUCH	16
7	POWER SCHEME	17
8	PIN DESCRIPTIONS	18
8.1	POWER PINS	18
8.2	INTERFACES LOGIC PINS	19
8.3	OUTPUT DRIVER PINS	19
8.4	MIPI INTERFACE	20
8.5	SPI INTERFACE	20
8.6	TOUCH INTERFACE	20
8.7	OTHER PINS	21
9	MAXIMUM RATINGS	22
10	AC CHARACTERISTICS	23
10.1	MIPI CHARACTERISTICS	23
11	DC CHARACTERISTICS	26
12	RESET CHARACTERISTICS	28
13	COMMAND TABLE	29
14	COMMAND DESCRIPTION	31
14.1	USER COMMAND SET	31
14.1.1	NOP (00h)	31
14.1.2	Software Reset (01h)	32
14.1.3	Read ID (04h)	33
14.1.4	Read Display Mode (09h)	34
14.1.5	Read Display Power Mode (0Ah)	35
14.1.6	Read Display MADCTL (0Bh)	36
14.1.7	Read Color format (0Ch)	37
14.1.8	Read Display Image Mode (0Dh)	38
14.1.9	Read Signal Mode (0Eh)	39
14.1.10	Read Signal Mode (0Fh)	40
14.1.11	Sleep In (10h)	41
14.1.12	Sleep Out (11h)	42
14.1.13	Normal Display Mode On (13h)	43
14.1.14	Display Invert Mode Off (20h)	44
14.1.15	Display Invert Mode On (21h)	45

14.1.16	Display Off (28h)	46
14.1.17	Display On (29h)	47
14.1.18	Set Column (2AH)	48
14.1.19	Set Row (2BH)	49
14.1.20	Write memory start (2CH)	50
14.1.21	Set Tearing Off (34H)	51
14.1.22	Set Tearing On(35H)	52
14.1.23	Data Access Control (36H)	53
14.1.24	Idle Mode Off (38H)	55
14.1.26	Idle Mode On (39H)	56
14.1.27	Set Color format (3Ah)	57
14.1.28	Write memory Continue (3CH)	58
14.1.29	Set Tear Scanline (44h)	59
14.1.30	Get Scanline (45h)	60
14.1.31	Write Display Brightness (51h)	61
14.1.32	Set Display Brightness mode(53h)	62
14.1.33	Read Display Brightness mode(54h)	63
14.1.34	Set CABC control (55h)	64
14.1.35	Read CABC control (56h)	65
14.1.36	Set CABC Minimum Brightness (5Eh)	66
14.1.37	Read CABC Minimum Brightness (5Fh)	67
14.1.38	Read DDB Start (A1h)	68
14.1.39	Read DDB Continue (A8h)	69
15	POWER ON/OFF SEQUENCES	70
16	OTP PROGRAM FLOW CHART	71
17	PACKAGE INFORMATION	72
17.1	CHIP TRAY INFORMATION	72

TABLES

TABLE 3-1: ORDERING INFORMATION	8
TABLE 5-1: DIE INFORMATION	10
TABLE 6-1: MIPI BUS CONFIGURATION	11
TABLE 6-2: INTERFACE SELECTION	11
TABLE 8-1: POWER SUPPLY PINS.....	18
TABLE 8-2: POWER GENERATION / REGULATION PINS	18
TABLE 8-3: INTERFACES LOGIC PINS	19
TABLE 8-4: OUTPUT DRIVER PINS	19
TABLE 8-5: MIPI INTERFACES PINS.....	20
TABLE 8-6: SPI INTERFACES PINS	20
TABLE 8-7: TOUCH INTERFACES PINS.....	20
TABLE 8-8: OTHER PINS	21
TABLE 8-1: MAXIMUM RATING (VOLTAGE REFERENCE TO VSS).....	22
TABLE 10-1: MIPI DPHY CHARACTERISTICS	23
TABLE 10-2: GLOBAL OPERATION TIMING PARAMETERS.....	24
TABLE 11-1: DC CHARACTERISTICS.....	26
TABLE 11-2: CURRENT CONSUMPTIONS (TO BE UPDATED).....	27
TABLE 11-3: MIPI DC CHARACTERISTICS	27
TABLE 12-1: RESET CHARACTERISTICS	28
TABLE 13-1: USER COMMAND SET TABLE	29

Confidential

FIGURES

FIGURE 4-1: L-WEA2010 BLOCK DIAGRAM	9
FIGURE 5-1: ALIGNMENT MARKS	10
FIGURE 5-2: PAD ARRANGEMENT (DIE FACE-UP, ALL IN UM).....	10
FIGURE 5-3: L-WEA2010 DIE PAD FLOOR PLAN	10
FIGURE 6-1: 4-WIRE SPI WRITE COMMAND AND WRITE DATA.....	12
FIGURE 6-2: 4-WIRE SPI WRITE RAM DATA	12
FIGURE 6-3: 4-WIRE SPI READ	12
FIGURE 6-4: 4-WIRE DSPI WRITE COMMAND AND WRITE DATA.....	13
FIGURE 6-5: 4-WIRE DSPI WRITE RAM DATA	13
FIGURE 6-6: 4-WIRE DSPI READ	13
FIGURE 6-7: 3-WIRE SPI WRITE COMMAND AND WRITE DATA.....	14
FIGURE 6-8: 3-WIRE SPI WRITE RAM DATA	14
FIGURE 6-9: 3-WIRE SPI READ	14
FIGURE 6-10: QSPI WRITE COMMAND AND WRITE DATA (1 DATA LANE).....	15
FIGURE 6-11: QSPI WRITE COMMAND AND WRITE DATA (4 DATA LANES).....	15
FIGURE 6-12: QSPI READ.....	15
FIGURE 10-1: HIGH-SPEED DATA TRANSMISSION IN BURSTS	25
FIGURE 10-2: SWITCHING THE CLOCK LANE BETWEEN CLOCK TRANSMISSION AND LOW POWER MODE	25
FIGURE 10-3: MIPI BUS TURNAROUND PROCEDURE.....	25
FIGURE 11-1: MIPI SIGNAL VOLTAGE LEVEL	27
FIGURE 12-1: RESET OPERATION.....	28
FIGURE 15-1: POWER ON/OFF SEQUENCE	70

Confidential

1 GENERAL DESCRIPTION

L-WEA2010 is a display driver supporting a-Si panel up to 454RGB x 454 resolution with 24bit color depth. The IC has integrated with RAM and self-cap incell touch controller.

2 FEATURES

Display

- IOT solution for TFT display
- Support various resolution, from 240RGB x 240 to 454RGB x 454
- Display color modes: 16.7M color (24bit – 8R:8G:8B)
- Support Column/1dot/2dot inversion
- Dual Gate GIP driving

Touch

- Low Power Touch Standby mode
- Support max 49 touch nodes sensing signal
- Support Vblank touch sensing mode, up to 60Hz report rate
- I2C/SPI for communication with Host (AP)
- 8 channels virtual touch key

Interface

- MIPI
 - MIPI lane speed up to 500Mbps per lane
 - MIPI DSI (version 1.1) with D-PHY (version 1.1)
 - Support command mode
 - Command set compliant with MIPI DCS (version 1.4)
 - 1 data lane and 1 clock lane
- SPI
 - Support SPI/DSPI/QSPI
 - 1/2/4 data lane and 1 clock lane
 - Data rate up to 40Mbps

RAM

- Embedded 103058 bytes RAM (454x454/2)

Power

- Power Supply
 - VDDIO: 1.65V – 3.3V
 - VCI: 2.5V ~ 3.3V
- Max VGH – VGL: 28Vp-p
- Low Current Sleep Mode and 8-color display mode for power saving

Function

- Programmable Gamma Correction Curve
- Programmable VCOM (-0.2V ~ -2.7V)
- CABC dynamics backlight control with PWM output

3 ORDERING INFORMATION

Table 3-1: Ordering Information

Ordering Part Number	Package Form	Remark
L-WEA2010Z	COG	

Confidential

4 BLOCK DIAGRAM

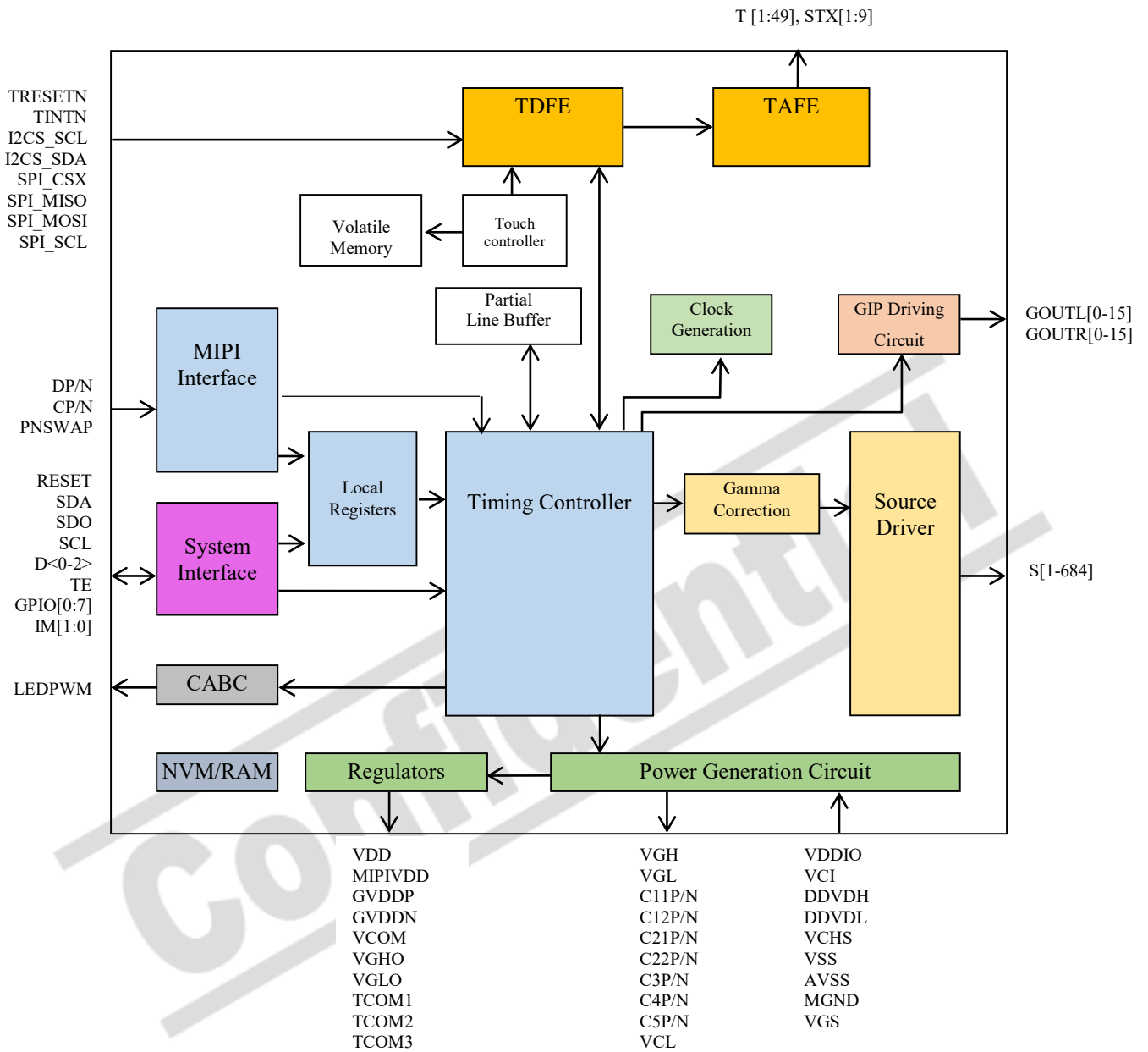

Figure 4-1: L-WEA2010 Block Diagram

5 DIE PAD FLOOR PLAN

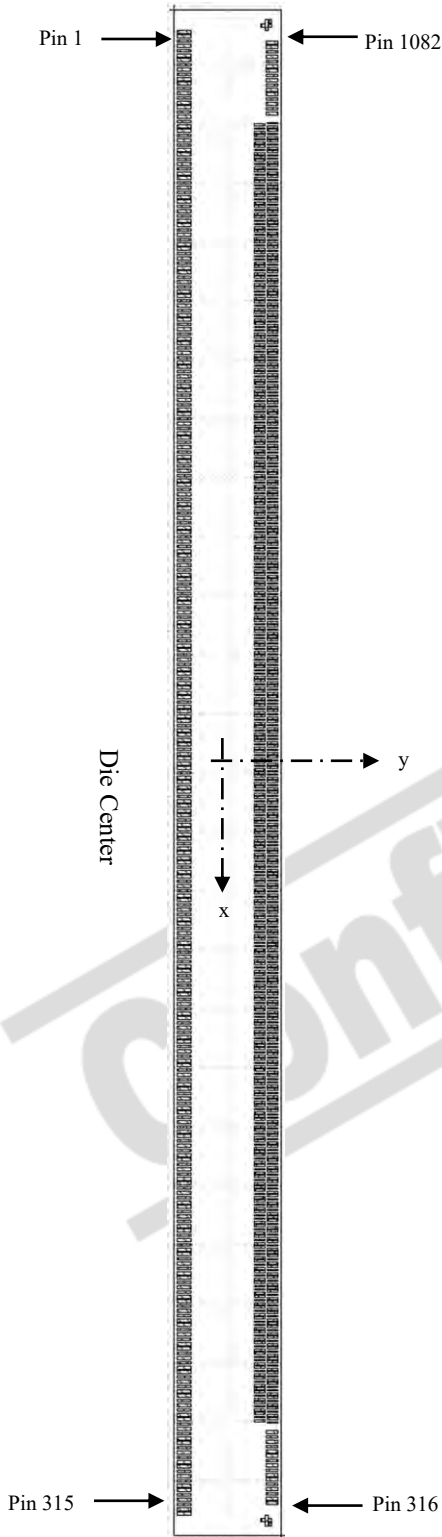

Figure 5-3: L-WEA2010 Die Pad Floor Plan (die face up)

Alignment Mark (center)	X (um)	Y (um)
Left	-6333.8	330.8
Right	6333.8	330.8

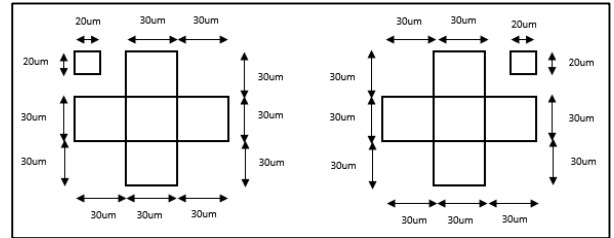

Figure 5-1: Alignment Marks

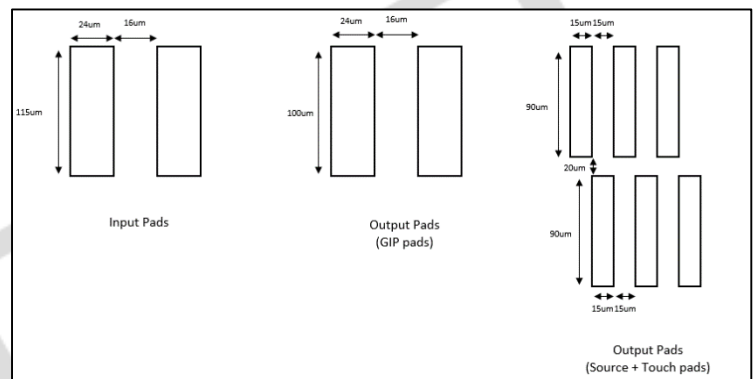

Figure 5-2: Pad Arrangement (die face-up, all in um)

Table 5-1: Die Information

Die Size	13004um x 998um (w/ scribe line)
Die Thickness	200um
Typical Bump Height	9 um
Bump Co-planarity (within die)	≤ 2 um
Bump Size 1	24 x 115 μm ² (pin 1-315)
Pad Pitch 1	40 μm
Bump Size 2	24 x 100 μm ² (pin 316-331,1067-1082)
Pad Pitch 2	40 um
Bump Size 3	15 x 90 μm ² (pin 332-1066)
Pad Pitch 3	30 um, 2 layers stagger
Bump Hardness	90 +/-20 Hv

Note

- (1) Coordinates are referenced to center of the chip.
- (2) Coordinate units and size of all alignment marks are in um.
- (3) All alignment keys do not contain gold bump.

6 BLOCK FUNCTION DESCRIPTION

6.1 MIPI Interface

L-WEA2010 supports MIPI DSI interface which can be used to transmit display data. It can also be used to program the L-WEA2010 registers.

The MIPI DPHY in L-WEA2010 supports flexible data and clock lane polarity swap. It is controlled by hardware pin. Please see the diagram below for possible arrangement.

Table 6-1: MIPI Bus Configuration

Physical Pin	DP	DN	CP	CN
PNSWAP	Functional Output			
1	DP	DN	CP	CN
0	DN	DP	CN	CP

6.2 System Interface

L-WEA2010 supports SPI interface which can be used to transmit display data. It can also be used to program the L-WEA2010 registers.

SPI/DSPI/QSPI are supported.

SPI interface or MIPI interface is selected by hardware pins IM[0:1].

Table 6-2: Interface Selection

IM[1]	IM[0]	Interface	Used pins
0	0	Reserved	-
0	1	4-wire SPI (0xE4=0)	PNSWAP(CSX), TEST_I[2](DCX), SCL, SDA
0	1	4-wire DSPI (0xE4=1)	PNSWAP(CSX), TEST_I[2](DCX), SCL, SDA, D[0]
1	0	MIPI	PNSWAP, CP, CN, DP, DN
1	1	3-wire SPI	PNSWAP(CSX), TEST_I[2](DCX)=GND, SCL, SDA
1	1	QSPI	PNSWAP(CSX), TEST_I[2](DCX)=VDDIO, SCL, SDA, D[0:2]

6.2.1 4-wire SPI Timing

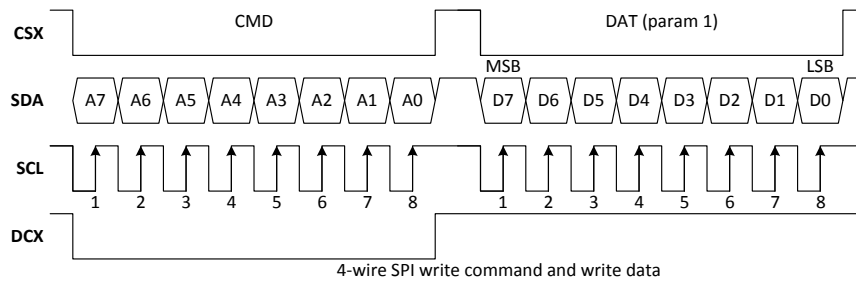

Figure 6-1: 4-wire SPI write command and write data

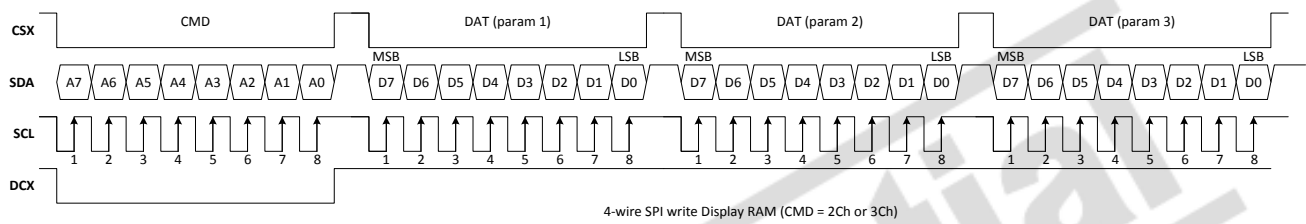

Figure 6-2: 4-wire SPI write RAM data

(Note: for each time using 0x2C or 0x3C cmd to write RAM data, please write 4 pixels data or more.)

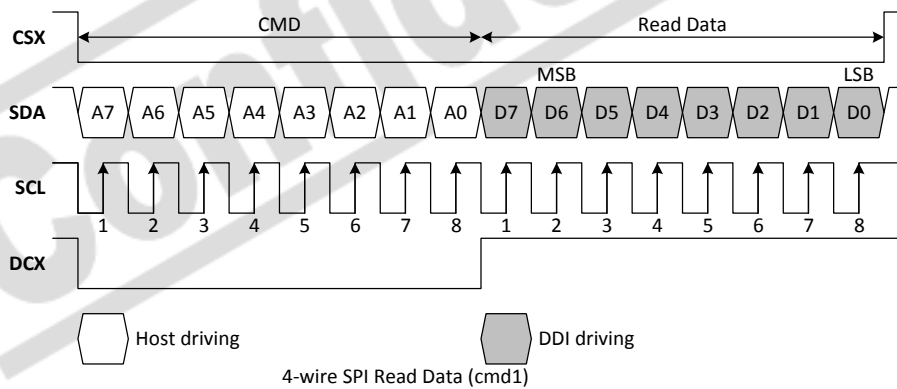

Figure 6-3: 4-wire SPI Read

6.2.2 4-wire DSPI Timing

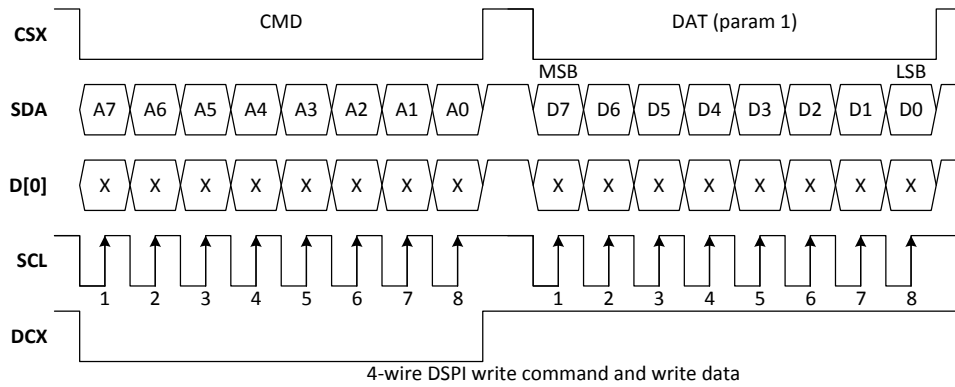

Figure 6-4: 4-wire DSPI write command and write data

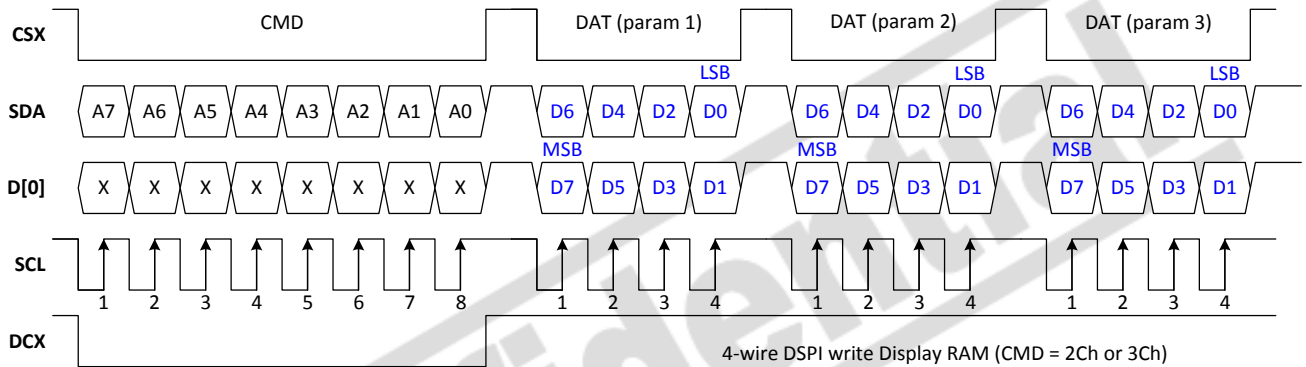

Figure 6-5: 4-wire DSPI write RAM data

(Note: for each time using 0x2C or 0x3C cmd to write RAM data, please write 4 pixels data or more.)

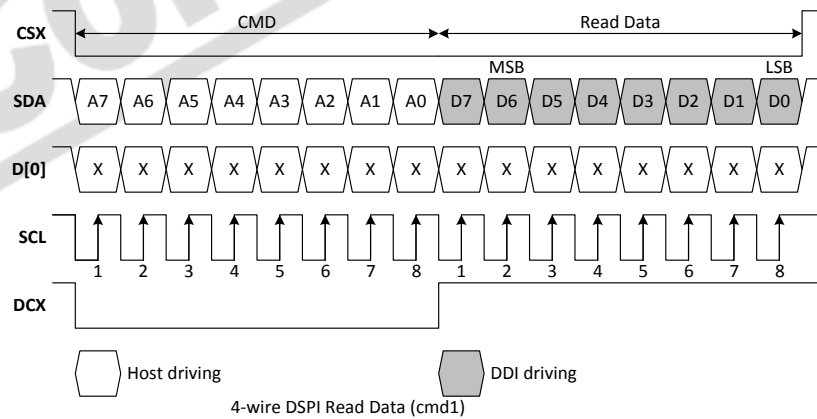

Figure 6-6: 4-wire DSPI Read

6.2.3 3-wire SPI Timing

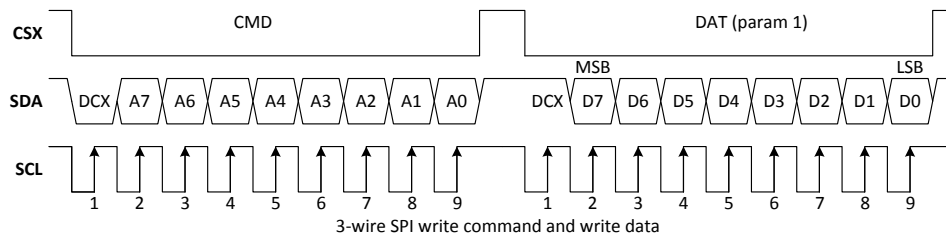

Figure 6-7: 3-wire SPI write command and write data

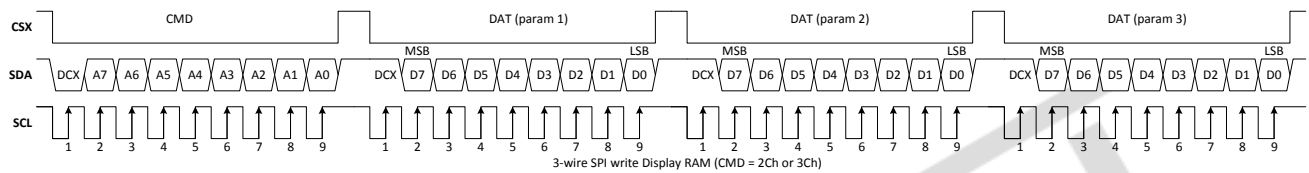

Figure 6-8: 3-wire SPI write RAM data

(Note: for each time using 0x2C or 0x3C cmd to write RAM data, please write 4 pixels data or more.)

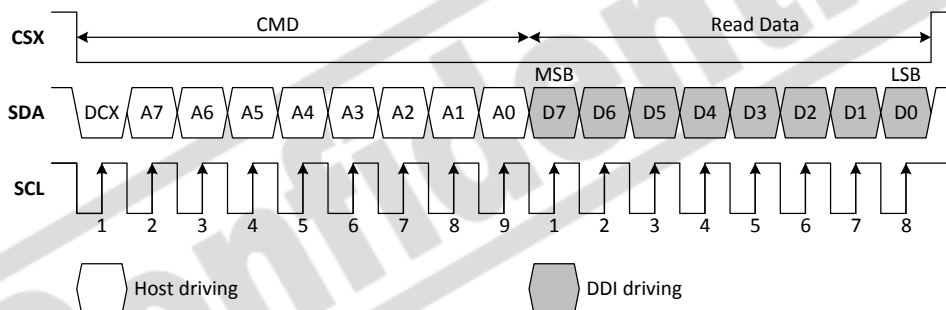

Figure 6-9: 3-wire SPI Read

6.2.4 QSPI Timing

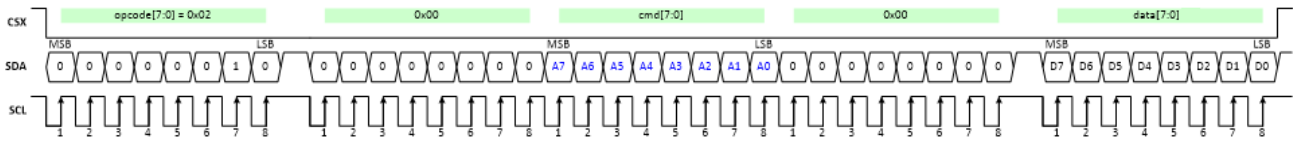

Figure 6-10: QSPI write command and write data (1 data lane)

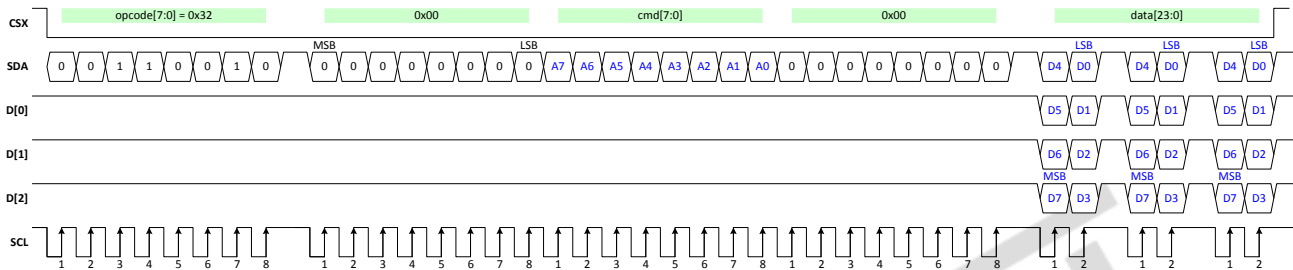

Figure 6-11: QSPI write command and write data (4 data lanes)

(Note: for each time using 0x2C or 0x3C cmd to write RAM data, please write 4 pixels data or more.)

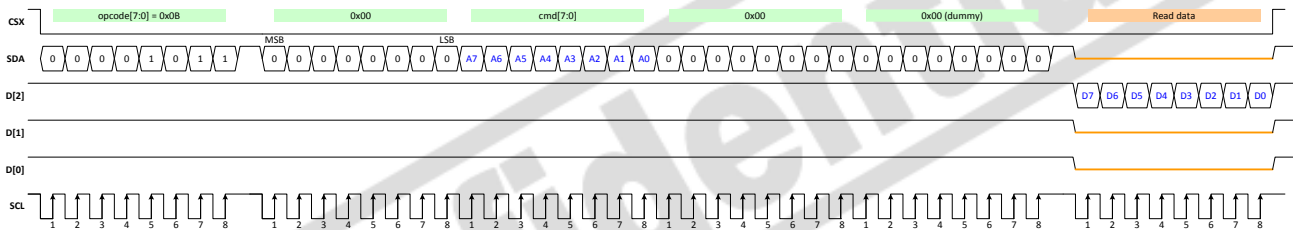

Figure 6-12: QSPI Read

6.3 Regulator / Power Generation Circuit

This block generates the voltage of VGH, VGL, VCOM etc which are necessary for operating L-WEA2010.

6.4 GIP Driving Circuits

This block generates the controls signals that are used in the Gate-Driver In Panel (GIP). Dual gate driving is supported.

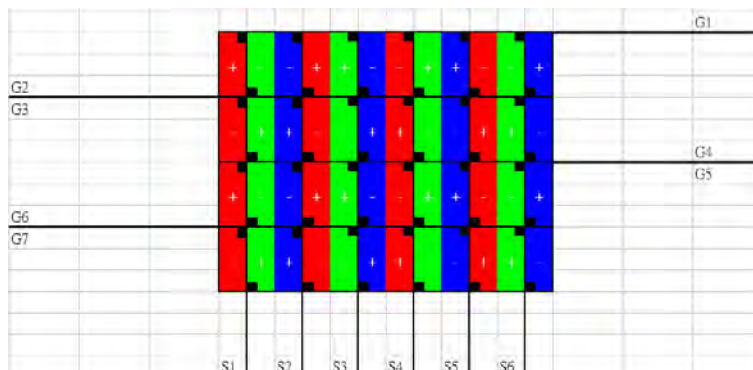

6.5 RAM

There are 103058 bytes RAM (456x456/2). RAM must be written as 1 pixel (3 bytes for 16.7M/262k color format, 2 bytes for 65k color format). Number of pixel must be in multiple of 4.

Use 0x2C and 0x3C to write whole frame data. (Please do not only use 0x2C to write whole frame data.) For each time using 0x2C or 0x3C command to write RAM data, please write 4 pixels data or more.

Read RAM is not supported.

6.6 Non-Volatile Memory (NVM)

NVM is available. It has a reserved area for below purpose. Each one can be programmed multiple times.

- Vendor ID
- VCOM tuning
- Full Gamma setting

6.7 Clock Generation Circuit

L-WEA2010 supports generating operational clock by itself through local oscillator and PLL.

6.8 Touch

L-WEA2010 has integrated the Touch Module Controller (TMC), Touch Digital Front End (TDFE), and Touch Analog Front End (TAFE).

TMC is able to process all the raw touch data and generate the final touch location and communicate with the AP.

7 POWER SCHEME

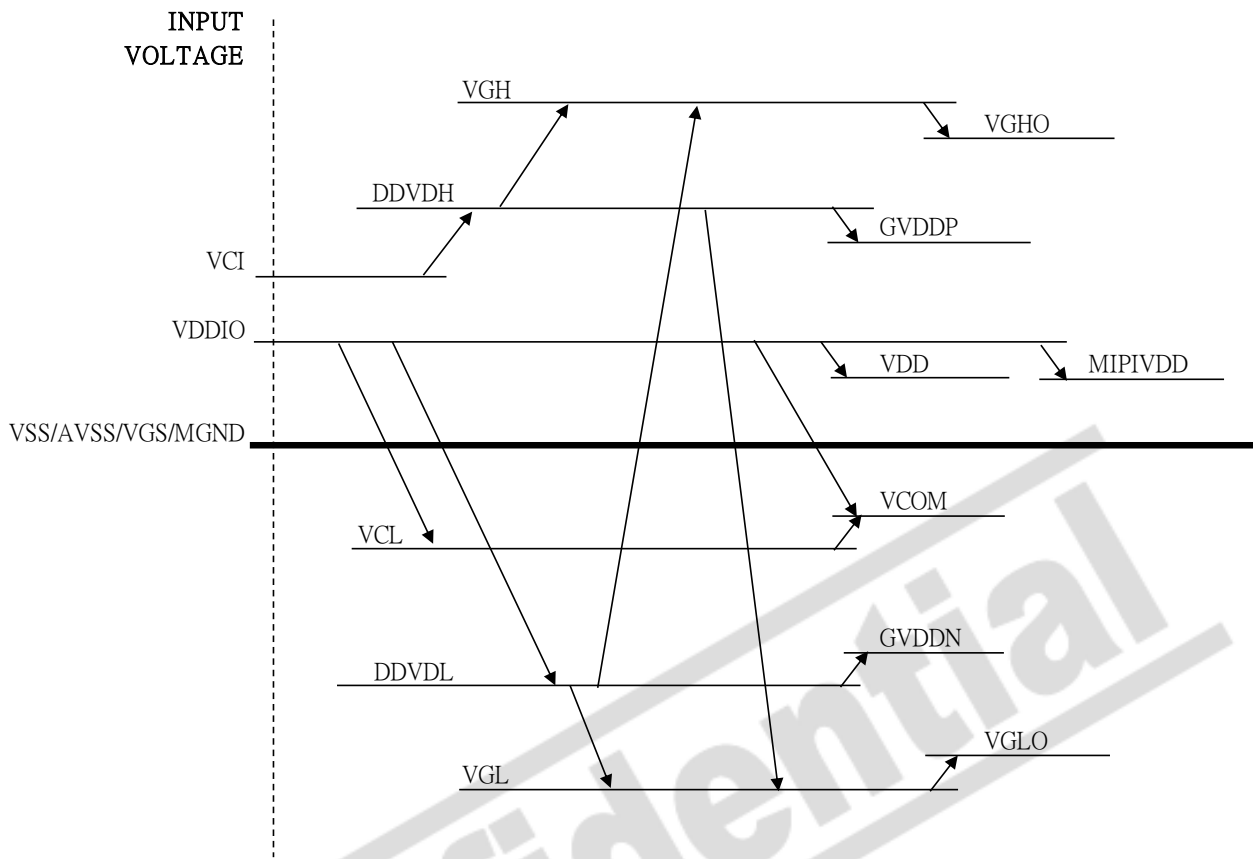

8 PIN DESCRIPTIONS

Key:

I = Input
 O =Output
 IO = Bi-directional (input/output)
 P = Power pin
 GIP = Gate In Panel
 BLU = Back Light Unit

8.1 Power Pins

Table 8-1: Power Supply Pins

Name	Type	Connect to	Function	Description	When not in use
VDDIO	P	Power Supply	Power supply for logic I/O	Power Supply for logic I/O - Connect to voltage source between 1.65V to 3.3V	-
VCI	P	Power Supply	Power supply for Analog	Power Supply for analog circuit - Connect to voltage source between 2.5V to 3.3V	-
AVSS	P	GND	Ground of the Power Supply	Analog circuit ground	-
VSS	P	GND	Ground of the Power Supply	System ground pin	-
MGND	P	GND	Ground of MIPI logic	MIPI analog circuit ground pin	-
VGS	P	GND	Reference Voltage	VGS is the ground reference voltage for gamma circuit.	-

Table 8-2: Power Generation / Regulation Pins

Name	Type	Connect to	Function	Description	When not in use
VCOM	O	LCD	LCD Driving Voltage	Supply voltage to the common electrode of TFT panel	-
VGH	I/O	Stabilizing Capacitor	LCD Driving Voltage	A positive power output pin for gate driver	-
VGL	I/O	Stabilizing Capacitor	LCD Driving Voltage	A negative power output pin for gate driver	-
VGHO	O	Stabilizing Capacitor	LCD Driving Voltage	A regulated positive power output pin for gate driver	-
VGLO	O	Stabilizing Capacitor	LCD Driving Voltage	A regulated negative power output pin for gate driver	-
DDVDH	O	Stabilizing Capacitor	LCD Driving Voltage	Positive power supply for LCD driving	-
DDVDL	O	Stabilizing Capacitor	LCD Driving Voltage	Positive power supply for LCD driving	-
VCL	O	Stabilizing Capacitor	LCD Driving Voltage	A negative power output pin for driver IC internal circuit.	-
GVDDP	O	Stabilizing Capacitor	Reference Voltage	VREG1OUT is a positive source driver grayscale reference voltage	-
GVDDN	O	Stabilizing Capacitor	Reference Voltage	VREG2OUT is a negative source driver grayscale reference voltage	-
MIPIVDD	O	Stabilizing Capacitor	Power supply for MIPI circuits	Regulator output that needed to be connected with stabilizing capacitor for MIPI block	-
VDD	O	Stabilizing Capacitor	Power supply for logic circuits	Power Supply for logic circuits	-
C21N, C21P	I/O	Step-up capacitor	Booster Circuit	Connect booster capacitors to generate DDVDL.	Open
C22N, C22P	I/O	Step-up capacitor	Booster Circuit	Connect booster capacitors to generate DDVDL	Open
C11N, C11P	I/O	Step-up capacitor	Booster Circuit	Connect booster capacitors to generate DDVDH	Open
C12N, C12P	I/O	Step-up capacitor	Booster Circuit	Connect booster capacitors to generate DDVDH	Open
C3N, C3P	I/O	Step-up capacitor	Booster Circuit	Connect booster capacitors to generate VCL	Open

Name	Type	Connect to	Function	Description	When not in use
C4N, C4P	I/O	Step-up capacitor	Booster Circuit	Connect booster capacitors to generate VGH	Open
C5N, C5P	I/O	Step-up capacitor	Booster Circuit	Connect booster capacitors to generate VGL	Open
TCOM1	O	Stabilizing Capacitor	Touch Driving Voltage	Used for touch application	Open
TCOM2	O	Stabilizing Capacitor	Touch Driving Voltage	Used for touch application	Open
TCOM3	O	Stabilizing Capacitor	Touch Driving Voltage	Used for touch application	Open

8.2 Interfaces Logic Pins

Table 8-3: Interfaces Logic Pins

Name	Type	Connect to	Function	Description	When not in use																					
RESET	I	MPU	System Reset	System reset pin. (active low)	VDDIO																					
TE	O	MPU	Logic Control	Frame head pulse signal. Utilize this signal when synchronizing RAM data write operations.	Open																					
LED_PWM	O	BLU	-	BLU PWM signal	Open																					
IM[0:1]	I	MPU	-	Interface selection:	-																					
				<table border="1"> <thead> <tr> <th>IM[1]</th> <th>IM[0]</th> <th>Interface</th> </tr> </thead> <tbody> <tr> <td>0</td> <td>0</td> <td>Reserved</td> </tr> <tr> <td>0</td> <td>1</td> <td>4-wire SPI (0xE4=0)</td> </tr> <tr> <td>0</td> <td>1</td> <td>4-wire DSPI (0xE4=1)</td> </tr> <tr> <td>1</td> <td>0</td> <td>MIPI</td> </tr> <tr> <td>1</td> <td>1</td> <td>3-wire SPI (DCX=GND)</td> </tr> <tr> <td>1</td> <td>1</td> <td>QSPI (DCX=VDDIO)</td> </tr> </tbody> </table>		IM[1]	IM[0]	Interface	0	0	Reserved	0	1	4-wire SPI (0xE4=0)	0	1	4-wire DSPI (0xE4=1)	1	0	MIPI	1	1	3-wire SPI (DCX=GND)	1	1	QSPI (DCX=VDDIO)
				IM[1]		IM[0]	Interface																			
				0		0	Reserved																			
				0		1	4-wire SPI (0xE4=0)																			
				0		1	4-wire DSPI (0xE4=1)																			
				1		0	MIPI																			
1	1	3-wire SPI (DCX=GND)																								
1	1	QSPI (DCX=VDDIO)																								

8.3 Output Driver Pins

Table 8-4: Output Driver Pins

Name	Type	Connect to	Function	Description	When not in use
GOUTL[0-15] GOUTR[0-15]	O	LCD	GIP Control Signals	These pins are used for GIP control signal. Unused pins should leave open	Open
S[1-684]	O	LCD	LCD Driving Signals	Source driver output pins	Open

8.4 MIPI Interface

Table 8-5: MIPI Interfaces Pins

Name	Type	Connect to	Function	Description	When not in use
DP	I/O	MIPI Interface Signal	MIPI differential Data Pair	Positive polarity of low voltage differential data signal	Open/VSS
DN				Negative polarity of low voltage differential data signal	Open/VSS
CP	I		MIPI differential Clock Pair	Positive polarity of low voltage differential clock signal	Open/VSS
CN	I			Negative polarity of low voltage differential clock signal	Open/VSS
PNSWAP	I	MPU	Logic Control	PNSWAP polarity swap of MIPI signal	VDDIO

8.5 SPI Interface

Table 8-6: SPI Interfaces Pins

Name	Type	Connect to	Function	Description	When not in use
SCL	I	MPU	SPI	SPI clock signal	VSS
SDA	I		SPI	SPI data signal	VSS
D[0:2]	I		SPI	SPI data signal	VSS

8.6 Touch Interface

Table 8-7: Touch Interfaces Pins

Name	Type	Connect to	Function	Description	When not in use
TRESETN	I	MPU	Touch reset	Reset signal for touch circuit	VSS
SPI_CSX	I	Flash/MPU	SPI	SPI chip selection pin	VSS
SPI_MISO	I	Flash/MPU	SPI	SPI Data Output pin	VSS
SPI_MOSI	O	Flash/MPU	SPI	SPI Data Input pin	Open
SPI_SCL	I	Flash/MPU	SPI	SPI Clock pin	VSS
I2CS_SDA	I	MPU	I2C	Serial data pin of I2C interface for touch circuit	VSS
I2CS_SCL	I	MPU	I2C	Serial clock pin of I2C interface for touch circuit	VSS
TINTN	I	MPU	Touch interrupt	Interrupt signal for touch circuit	VSS
STX[1:9]	O	LCD	Touch control signal	Touch key channels	Open
T[1-49]	I/O	LCD	Touch control signal/VCOM	Touch channels/VCOM	Open

8.7 Other Pins

Table 8-8: Other Pins

Name	Type	Connect to	Function	Description	When not in use
DBIST	I	-	-	Test pin	VSS
GPO[0:7]	I/O	-	-	Test pin	Open
CL	O	-	-	Test pin	Open
VCOM_OPT[0:1]	O			Test pin	Open
DUMMY	-	-	-	Dummy pin	Open
TEST_I[0:2]	I			Test pin	VSS

Confidential

9 MAXIMUM RATINGS

Table 9-1: Maximum Rating (Voltage reference to VSS)

Symbol	Parameter	Pin	Value	Unit
VDDIO	Supply Voltage	VDDIO	-0.3 to +3.3	V
VCI		VCI	-0.3 to +3.3	V
VGH-VGL	Gate Driver Supply Voltage	-	-0.3 to +28.0	V
DP, DN CP, CN	Differential Input Voltage	-	1.65	V
T _A	Operating Temperature	-	-40 to +85	°C
T _{STG}	Storage Temperature	-	-55 to +125	°C

Maximum ratings are those values beyond which damages to the device may occur. Functional operation should be restricted to the limits in the Electrical Characteristics tables or Pin Description section.

Display driver IC is a UV sensitive device; so do not let the front or backside of an IC under UV exposure. An appropriate coating, module design and assembly methods to adequately protect the IC from UV are required for application.

This device contains circuitry to protect the inputs against damage due to high static voltages or electric fields; however, it is advised that normal precautions to be taken to avoid application of any voltage higher than maximum rated voltages to this high impedance circuit. Reliability of operation is enhanced if unused input is connected to an appropriate logic voltage level (e.g., either VSS or VDDIO). Unused outputs must be left open. This device may be light sensitive. Caution should be taken to avoid exposure of this device to any light source during normal operation. This device is not radiation protected.

10 AC CHARACTERISTICS

10.1 MIPI CHARACTERISTICS

Table 10-1: MIPI DPHY Characteristics

Symbol	Parameter	Test Condition	Min	Typ	Max	Unit
MIPI HS Receiver						
F _{SPEED}	MIPI Data Lane Speed	Please see Note 1	400		500	Mbps
UI	Unit Interval	Please see Note 2	2			ns
T _{SETUP}	Data to Clock Setup Time	Please see Note 3	0.2			UI
T _{HOLD}	Data to Clock Hold Time	Please see Note 3	0.2			UI
T _{SKEW}	Data to Clock Skew	Please see Note 4	-0.2			UI
MIPI LP Receiver						
T _{LTX}	LP transmission pulse width		50			ns

Note 1: The MIPI data lane speed depends on the number of data lanes, the bit per pixel (bpp) value of the display data and the operation mode (command mode).

Note 2: $UI = 1 / F_{SPEED}$

Note 3: Total setup and hold window for receiver of $0.3 * UI$ when max rate less than 1Gbps.

Note 4: Total silicon and package skew delay budget of $0.3 * UI$ when max rate less than 1Gbps.

Confidential

Table 10-2: Global Operation Timing Parameters

Symbol	Parameter	Min	Typ	Max	Unit
T _{CLK-POST}	Time that the transmitter shall continue sending HS clock after the last associated Data Lane has transitioned to LP mode. Interval is defined as the period from the end of T _{HS-TRAIL} to the beginning of T _{CLK-TRAIL} .	60ns + 52UI			ns
T _{CLK-PRE}	Minimum time that the HS clock shall be driven prior to any associated Data Lane beginning the transition from LP to HS mode	8			UI
T _{CLK-PREPARE}	Time that the transmitter drives the Clock Lane LP-00 Line state immediately before the HS-0 Line state starting the HS transmission.	38		95	ns
T _{CLK-SETTLE}	Time interval during which the HS receiver shall ignore any Clock Lane HS transitions, starting from the beginning of T _{CLK-PREPARE} .	95		300	ns
T _{CLK-TERM-EN}	Time for the Clock Lane receiver to enable the HS line termination, starting from the time point when Dn crosses V _{IL,MAX} .			38	ns
T _{CLK-TRAIL}	Time that the transmitter drives the HS-0 state after the last payload clock bit of a HS transmission burst.	60			ns
T _{CLK-PREPARE} + T _{CLK-ZERO}	T _{CLK-PREPARE} + time that the transmitter drives the HS-0 state prior to starting the Clock.	300			ns
T _{D-TERM-EN}	Time for the Data Lane receiver to enable the HS line termination, starting from the time point when Dn crosses V _{IL,MAX} .			35ns + 4UI	ns
T _{EOT}	Transmitted time interval from the start of T _{HS-TRAIL} or T _{CLK-TRAIL} , to the start of the LP-11 state following a HS burst.			105ns + n*12UI	ns
T _{HS-EXIT}	Time that the transmitter drives LP-11 following a HS burst.	100			ns
T _{HS-PREPARE}	Time that the transmitter drives the Data Lane LP-00 Line state immediately before the HS-0 Line state starting the HS transmission	40ns + 4UI		85ns + 6UI	ns
T _{HS-PREPARE} + T _{HS-ZERO}	T _{HS-PREPARE} + time that the transmitter drives the HS-0 state prior to transmitting the Sync sequence.	145ns + 10UI			ns
T _{HS-ZERO}	Time that the transmitter drives the HS-0 state prior to transmitting the Sync sequence	100			ns
T _{HS-SETTLE}	Time interval during which the HS receiver shall ignore any Data Lane HS transitions, starting from the beginning of T _{HS-PREPARE} .	85ns + 6UI		145ns + 10UI	ns
T _{HS-SKIP}	Time interval during which the HS-RX should ignore any transitions on the Data Lane, following a HS burst. The end point of the interval is defined as the beginning of the LP-11 state following the HS burst.	40		55 ns + 4*UI	ns
T _{HS-TRAIL}	Time that the transmitter drives the flipped differential state after last payload data bit of a HS transmission burst.	100			ns
T _{LPX}	Transmitted length of any Low-Power state period		100		ns
Ratio T _{LPX}	Ratio of T _{LPX(MASTER)} /T _{LPX(SLAVE)} between Master and Slave side	2/3		3/2	
T _{TA-GET}	Time to drive LP-00 by new TX		5T _{LPX}		
T _{TA-GO}	Time to drive LP-00 after Turnaround Request		4T _{LPX}		
T _{TA-SURE}	Time-out before new TX side starts driving	1*T _{LPX}		2*T _{LPX}	
T _{WAKEUP}	Time that a transmitter drives a Mark-1 state prior to a Stop state in order to initiate an exit from ULPS.	1			ms

Note: Please refer to the diagram below for the definition of the MIPI parameter.

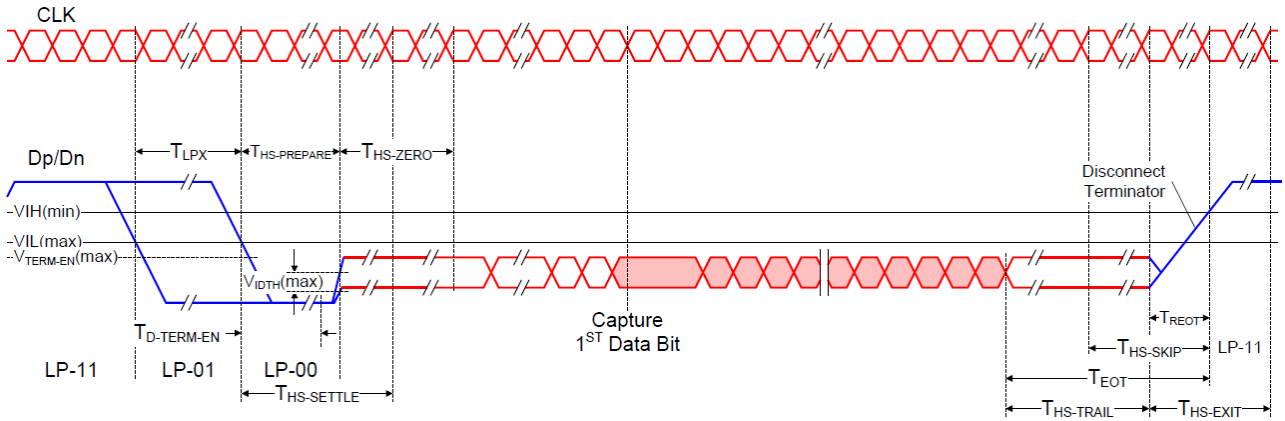

Figure 10-1: High-Speed Data Transmission in Bursts

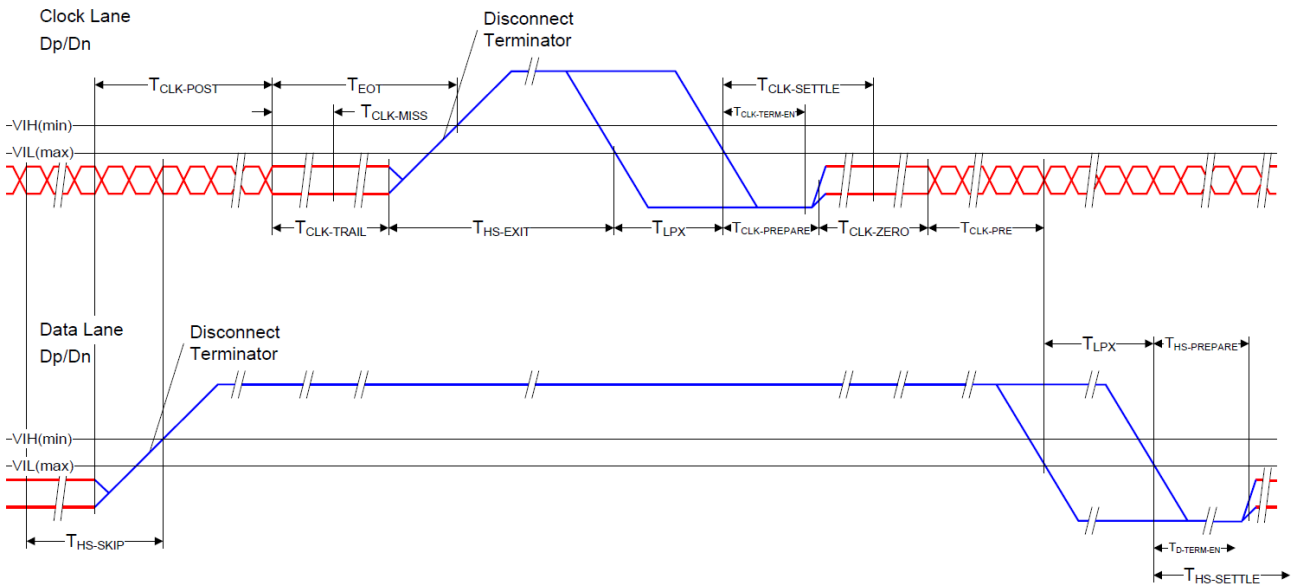

Figure 10-2: Switching the Clock Lane between Clock Transmission and Low Power Mode

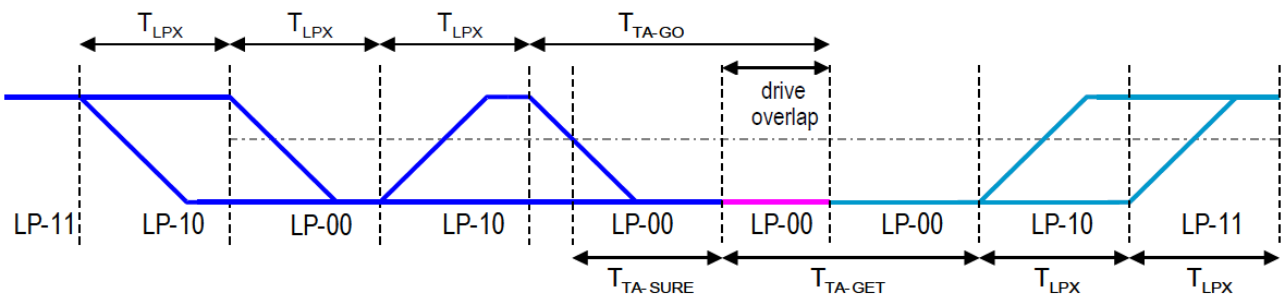

Figure 10-3: MIPI BUS Turnaround Procedure

11 DC CHARACTERISTICS

Table 11-1: DC Characteristics

(Unless otherwise specified, Voltage Referenced to VSS, TA = -40 to 85 °C)

Symbol	Parameter	Test Condition	Min	Typ	Max	Unit
Power Supply						
VDDIO	Power Supply for Logic circuit	-	1.65	-	3.30	V
VCI	Power Supply for Analog circuit	-	2.5	-	3.30	V
Digital IO Input/Output						
V _{IH}	Logic High Level Input voltage	-	0.8 * VDDIO	-	VDDIO	V
V _{IL}	Logic Low Level Input voltage	-	VSS	-	0.2 * VDDIO	V
V _{OH}	Logic High Level Output Voltage	I _{out} = 1mA	0.9 * VDDIO	-	VDDIO	V
V _{OL}	Logic Low Level Output Voltage	I _{out} = -1mA	VSS	-	0.1 * VDDIO	V
I _{IH}	Logic High Input Current Source (Non MIPI Pin)	-	-	-	1	μA
I _{IL}	Logic Low Input Current Drain (Non MIPI Pin)	-	-1	-	-	μA
I _{IH_M}	Logic High Input Current Source (MIPI Pin Only)	-	-	-	10	μA
I _{IL_M}	Logic Low Input Current Drain (MIPI Pin Only)	-	-10	-	-	μA
Power Generation / Regulation Output						
VDD	Power supply for Logic circuit	-	-	1.2	-	V
MIPIVDD	Regulated Output for MIPI logic circuits	-	-	1.2	-	V
VCOM	VCOM Voltage	-	-2.7	-	-0.2	V
DDVDH	Source Circuit Positive Power Supply	-	4.50	-	6.00	V
DDVDL	Source Circuit Negative Power Supply	-	-6.00	-	-4.50	V
VGH	GIP Pin Positive Power Supply	VCI=3.3V with No Loading	VCI- DDVDL	-	2x DDVDH - DDVDL	V
VGL	GIP Pin Negative Power Supply	-	2x DDVDL - DDVDH	-	DDVDL- VCI	V
	VGH-VGL	-	-	-	30	V
VGHO	Regulated positive power output pin for gate driver	-	6	-	15	V
VGLO	Regulated negative power output pin for gate driver	-	-14	-	-5	V
Source Driver						
Deviation	GVDDP/GVDDN deviation	Note 1,2 GVDDP/GVDDN set @ +/- 5.00V	-	-	45	mV
S _{off}	Source Output offset voltage	Note 1,2 VREG1OUT/VREG2OUT set @ +/-5.00V	-	-	45	mV

Note 1: VDDIO = 1.8V and at Room Temperature (25°C)

Note 2: VCI = 3V

Table 11-2: Current Consumptions (to be updated)

(Unless otherwise specified, Voltage Referenced to VSS, TA = 25 °C, Display Resolution is 454x454 @ 60Hz)

Symbol	Parameter	Test Condition	Min	Typ	Max	Unit	
Current Consumptions							
I _{sleep}	Sleep mode current	VDDIO = 1.8V DDVDH = 5.5V, DDVDL = -5.5V	VDDIO	-	TBD	-	μA
			DDVDH	-	TBD	-	μA
			DDVDL	-	TBD	-	μA
I _{DISPLAY}	Display on current	VDDIO = 1.8V DDVDH = 5.5V, DDVDL = -5.5V White pattern	VDDIO	-	TBD	-	mA
			DDVDH	-	TBD	-	mA
			DDVDL	-	TBD	-	mA

Note 1: VDDIO= 1.8V, VCI = 3V at Room Temperature (25°C)

Table 11-3: MIPI DC Characteristics

(Unless otherwise specified, Voltage Referenced to VSS, TA = -40 to 85 °C)

Symbol	Parameter	Test Condition	Min	Typ	Max	Unit
MIPI LP Transmitter						
V _{OH}	Thevenin output high level	-	1.15	1.2	1.35	V
V _{OL}	Thevenin output low level	-	-50	-	50	mV
MIPI LP Receiver						
V _{IH}	Logic 1 input voltage	-	880	-	-	mV
V _{IL}	Logic 0 input voltage	-	-	-	550	mV
MIPI HS Receiver						
V _{CMRX(DC)}	Common mode voltage, HS Receiver mode	-	70	-	330	mV
V _{IDTH}	Differential input high threshold	-	-	-	70	mV
V _{IDTL}	Differential input low threshold	-	-70	-	-	mV
V _{IHHS}	Single-ended input high voltage	-	-	-	460	mV
V _{ILHS}	Single-ended input low voltage	-	-40	-	-	mV
V _{TERM-EN}	Single-ended threshold for HS termination enable	-	-	-	450	mV
Z _{ID}	Differential input impedance	-	80	100	125	ohm

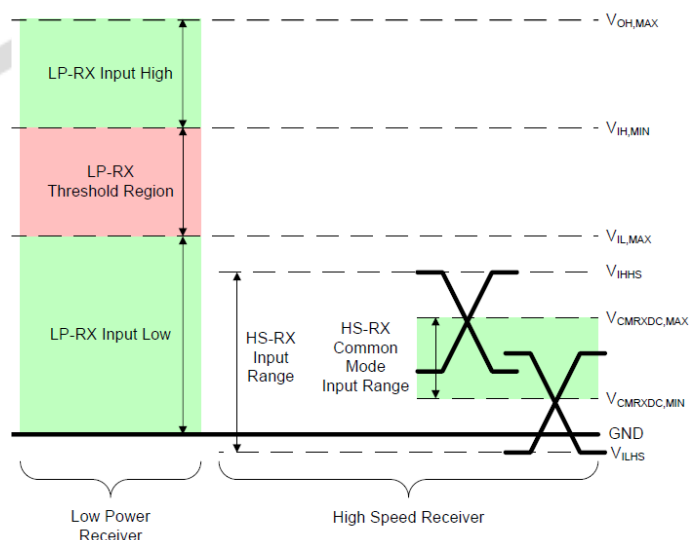

Figure 11-1: MIPI Signal Voltage Level

12 RESET CHARACTERISTICS

Table 12-1: Reset Characteristics

Item	Symbol	Unit	Test Condition	Min.	Typ.	Max.
Reset "Low" level width 1	tRW1	ms	Power On	1	-	-
Reset "Low" level width 2	tRW2	ms	Operation	1	-	-
Reset time	tRT	ms	-	20	-	-

Figure 12-1: Reset Operation

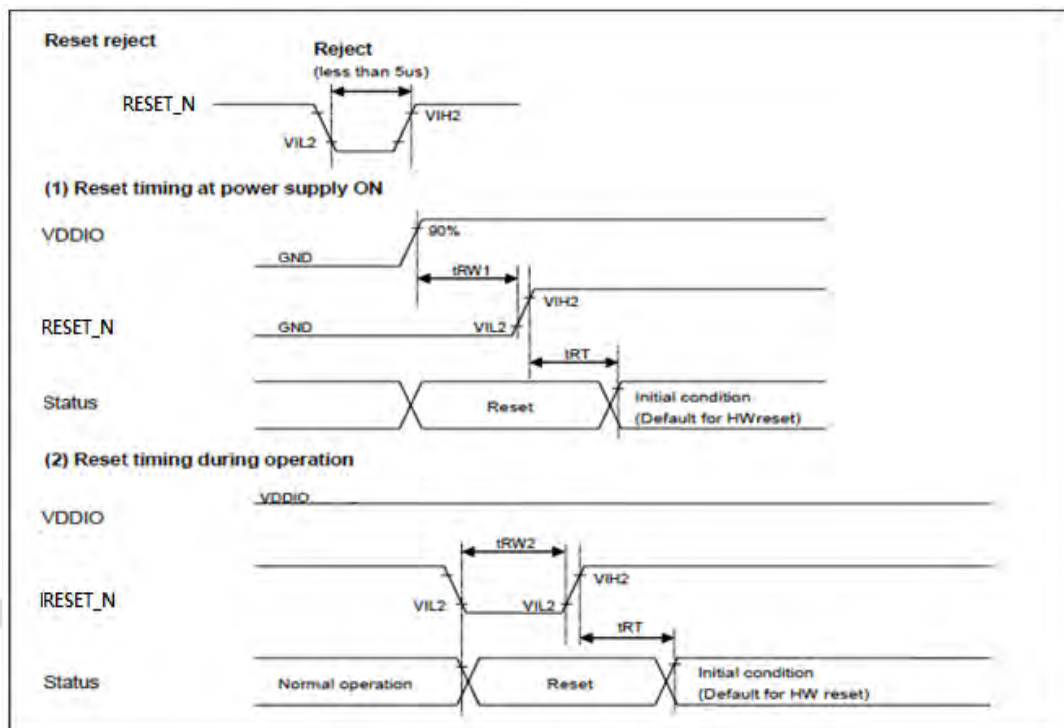

13 COMMAND TABLE

Table 13-1: User Command Set Table

Hex Code	Command	D/C	W/R	D7	D6	D5	D4	D3	D2	D1	D0
R00h	NOP	C	W	0	0	0	0	0	0	0	0
R01h	SWRESET	D	W	0	0	0	0	0	0	0	1
R04h	ID	C	W	0	0	0	0	0	1	0	0
	1st Parameter	D	R	ID1[7:0]							
	2nd Parameter	D	R	ID2[7:0]							
	3rd Parameter	D	R	ID3[7:0]							
R09h	RDISPMODE	C	W	0	0	0	0	1	0	0	1
	1st Parameter	D	R	0	0	0	0	RGB	0	SS	GS
	2nd Parameter	D	R	0	0	0	0	IDMON	0	SLPOUT	NORM
	3rd Parameter	D	R	0	0	INV	0	0	DISPON	TEON	0
	4th Parameter	D	R	0	0	TELOM	0	0	0	0	0
R0Ah	RDDPM	C	W	0	0	0	0	1	0	1	0
	1st Parameter	D	R	0	IDMON	0	SLPOUT	NORON	DISON	0	0
R0Bh	RDDMADCTL	C	W	0	0	0	0	1	0	1	1
	1st Parameter	D	R	0	0	0	0	BGR	0	SS	GS
R0Ch	RDPPIX	C	W	0	0	0	0	1	1	0	0
	1st Parameter	D	R	0	0	0	0	0	DBI[2:0]		
R0Dh	RDDIM	C	W	0	0	0	0	1	1	0	1
	1st Parameter	D	R	0	0	INV	0	0	0	0	0
R0Eh	RDDSM	C	W	0	0	0	0	1	1	1	0
	1st Parameter	D	R	TEON	TELOM	0	0	0	0	0	EDSI
R0Fh	RDDSDR	C	W	0	0	0	0	1	1	1	1
	1st Parameter	D	R	NVLD	FUND	0	0	0	0	0	0
R10h	SLPIN	C	W	0	0	0	1	0	0	0	0
R11h	SLPOUT	C	W	0	0	0	1	0	0	0	1
R13h	NORON	C	W	0	0	0	1	0	0	1	1
R20h	INVOFF	C	W	0	0	1	0	0	0	0	0
R21h	INVON	C	W	0	0	1	0	0	0	0	1
R28h	DISPOFF	C	W	0	0	1	0	1	0	0	0
R29h	DISPON	C	W	0	0	1	0	1	0	0	1
R2Ah	SETCOL	C	W	0	0	1	0	1	0	1	0
	1st Parameter	D	W	SC[15:8]							
	2nd Parameter	D	W	SC[7:0]							
	3rd Parameter	D	W	EC[15:8]							
	4th Parameter	D	W	EC[7:0]							
R2Bh	SETPAGE	C	W	0	0	1	0	1	0	1	1
	1st Parameter	D	W	SP[15:8]							
	2nd Parameter	D	W	SP[7:0]							
	3rd Parameter	D	W	EP[15:8]							
	4th Parameter	D	W	EP[7:0]							
R2Ch	WRMEMST	C	W	0	0	1	0	1	1	0	0
R34h	TEOFF	C	W	0	0	1	1	0	1	0	0
R35h	TEON	C	W	0	0	1	1	0	1	0	1
	1st Parameter	D	W	0	0	0	0	0	0	0	TELOM
R36h	MADCTR	C	W	0	0	1	1	0	1	1	0
	1st Parameter	D	W	0	0	0	ML	BGR	0	SS	GS
R38h	IDMOFF	C	W	0	0	1	1	1	0	0	0
R39h	IDMON	C	W	0	0	1	1	1	0	0	1
R3Ah	SETPIXEL	C	W	0	0	1	1	1	0	1	0
	1st Parameter	D	W	0	0	0	0	0	DBI[2:0]		
R3Ch	WRMEMCONT	C	W	0	0	1	1	1	1	0	0
R44h	TESS	C	W	0	1	0	0	0	1	0	0
	1st Parameter	D	W	STS [15:8]							
	2nd Parameter	D	W	STS[7:0]							
R45h	RSS	C	W	0	1	0	0	0	1	0	1
	1st Parameter	D	R	GTS [15:8]							
	2nd Parameter	D	R	GTS[7:0]							
R51h	SETBR	C	W	0	1	0	1	0	0	0	1
	1st Parameter	D	W	DBV[13:6]							
	2nd Parameter	D	W	0	0	DBV[5:0]					
R53h	SETMODE	C	W	0	1	0	1	0	0	1	1
	1st Parameter	D	W	0	0	BCTRL	0	DD	BL	0	0
R54h	RDMODE	C	W	0	1	0	1	0	1	0	0
	1st Parameter	D	R	0	0	BCTRL	0	DD	BL	0	0
R55h	SETPWR	C	W	0	1	0	1	0	1	0	1
	1st Parameter	D	W	0	0	0	0	0	PS[2:0]		

Hex Code	Command	D/C	W/R	D7	D6	D5	D4	D3	D2	D1	D0
R56h	RDPWR	C	W	0	1	0	1	0	1	1	0
	1st Parameter	D	R	0	0	0	0	0	PS[2:0]		
R5Eh	SETMINBR	C	W	0	1	0	1	1	1	1	0
	1st Parameter	D	W	CMB[13:6]							
	2nd Parameter	D	W	0	0	CMB[5:0]					
R5Fh	RDMINBR	C	W	0	1	0	1	1	1	1	1
	1st Parameter	D	R	CMB[15:8]							
	2nd Parameter	D	R	0	0	CMB[5:0]					
A1h	RDDDBST	C	W	1	0	1	0	0	0	0	1
A8h	RDDDBCON	C	W	1	0	1	0	1	0	0	0

Confidential

14 COMMAND DESCRIPTION

14.1 User Command Set

14.1.1 NOP (00h)

Hex Code	Command	D/C	WR	D7	D6	D5	D4	D3	D2	D1	D0	POR
R00h	NOP	C	W	0	0	0	0	0	0	0	0	-

Description	- This command is an empty command; it does not have any effect on the display module.	
Restriction	-	
Register Availability	Status	Availability
	Normal Mode On, Idle Mode Off, Sleep Out	Yes
	Normal Mode On, Idle Mode On, Sleep Out	Yes
	Sleep In	Yes

Confidential

14.1.2 Software Reset (01h)

Hex Code	Command	D/C	WR	D7	D6	D5	D4	D3	D2	D1	D0	POR
R01h	SWRESET	C	W	0	0	0	0	0	0	0	1	-

Description	<ul style="list-style-type: none"> - When the Software Reset command is written, it causes a software reset. It resets the commands and parameters to their S/W Reset default values (See default tables in each command description.). - The display is blank immediately. The display turns black or white immediately that depends on the panel type. 									
Restriction	<ul style="list-style-type: none"> - It will be necessary to wait 5msec before sending new command following software reset. - The display module loads all display module factory default values to the registers during 5msec. - If Software Reset is applied during Sleep Out mode, it will be necessary to wait 120msec before sending Sleep Out command. - Software Reset Command cannot be sent during Sleep Out sequence. - NVM will reload when hardware reset is applied. 									
Register Availability	<table border="1" style="width: 100%; border-collapse: collapse;"> <thead> <tr> <th style="width: 60%;">Status</th> <th style="width: 40%;">Availability</th> </tr> </thead> <tbody> <tr> <td>Normal Mode On, Idle Mode Off, Sleep Out</td> <td style="text-align: center;">Yes</td> </tr> <tr> <td>Normal Mode On, Idle Mode On, Sleep Out</td> <td style="text-align: center;">Yes</td> </tr> <tr> <td style="text-align: center;">Sleep In</td> <td style="text-align: center;">Yes</td> </tr> </tbody> </table>		Status	Availability	Normal Mode On, Idle Mode Off, Sleep Out	Yes	Normal Mode On, Idle Mode On, Sleep Out	Yes	Sleep In	Yes
Status	Availability									
Normal Mode On, Idle Mode Off, Sleep Out	Yes									
Normal Mode On, Idle Mode On, Sleep Out	Yes									
Sleep In	Yes									

Confidential

14.1.3 Read ID (04h)

Hex Code	Command	D/C	W/R	D7	D6	D5	D4	D3	D2	D1	D0	POR
R04h	ID	C	W	0	0	0	0	0	1	0	0	-
	1 st Parameter	D	R	ID1[7:0]							00h	
	2 nd Parameter	D	R	ID2[7:0]							00h	
	3 rd Parameter	D	R	ID3[7:0]							00h	

Description	- This command read back ID code.	
Restriction	-	
Register Availability	Status	
	Normal Mode On, Idle Mode Off, Sleep Out	
	Normal Mode On, Idle Mode On, Sleep Out	
	Sleep In	
	Availability	
	Yes	
	Yes	
	Yes	

Confidential

14.1.4 Read Display Mode (09h)

Hex Code	Command	D/C	W/R	D7	D6	D5	D4	D3	D2	D1	D0	POR
R09h	RDISPMODE	C	W	0	0	0	0	1	0	0	1	-
	1st Parameter	D	R	0	0	0	0	RGB	0	SS	GS	00h
	2nd Parameter	D	R	0	0	0	0	IDMON	0	SLPOUT	NORM	01h
	3rd Parameter	D	R	0	0	INV	0	0	DISPON	TEON	0	00h
	4th Parameter	D	R	0	0	TELOM	0	0	0	0	0	00h

Description	<p>RGB: RGB/BGR order status</p> <p>SS: Flip horizontal status</p> <p>GS: Flip vertical status</p> <p>IDMON: Idle mode status</p> <p>SLPOUT: Sleep out status</p> <p>NORM: Normal mode status</p> <p>INV: Inversion mode status</p> <p>DISPON: Display on status</p> <p>TEON: TE status</p> <p>TELOM: TE mode status</p>								
Restriction	-								
Register Availability	<table border="1"> <thead> <tr> <th>Status</th> <th>Availability</th> </tr> </thead> <tbody> <tr> <td>Normal Mode On, Idle Mode Off, Sleep Out</td> <td>Yes</td> </tr> <tr> <td>Normal Mode On, Idle Mode On, Sleep Out</td> <td>Yes</td> </tr> <tr> <td>Sleep In</td> <td>Yes</td> </tr> </tbody> </table>	Status	Availability	Normal Mode On, Idle Mode Off, Sleep Out	Yes	Normal Mode On, Idle Mode On, Sleep Out	Yes	Sleep In	Yes
Status	Availability								
Normal Mode On, Idle Mode Off, Sleep Out	Yes								
Normal Mode On, Idle Mode On, Sleep Out	Yes								
Sleep In	Yes								

14.1.5 Read Display Power Mode (0Ah)

Hex Code	Command	D/C	W/R	D7	D6	D5	D4	D3	D2	D1	D0	POR
R0Ah	RDDPM	0	W	0	0	0	0	1	0	1	0	-
	1 st Parameter	1	R	0	IDMON	0	SLPOUT	NORON	DISON	0	0	08h

Description	-This command indicates the current status of the display as described in the table below:								
	Bit	Bit Symbol							
	D7	Reserved							
	D6	IDMON							
	D5	Reserved							
	D4	SLPOUT							
	D3	NORON							
	D2	DISON							
	D1	Reserved							
D0	Reserved								
Restriction	-								
Register Availability	<table border="1"> <thead> <tr> <th>Status</th> <th>Availability</th> </tr> </thead> <tbody> <tr> <td>Normal Mode On, Idle Mode Off, Sleep Out</td> <td>Yes</td> </tr> <tr> <td>Normal Mode On, Idle Mode On, Sleep Out</td> <td>Yes</td> </tr> <tr> <td>Sleep In</td> <td>Yes</td> </tr> </tbody> </table>	Status	Availability	Normal Mode On, Idle Mode Off, Sleep Out	Yes	Normal Mode On, Idle Mode On, Sleep Out	Yes	Sleep In	Yes
Status	Availability								
Normal Mode On, Idle Mode Off, Sleep Out	Yes								
Normal Mode On, Idle Mode On, Sleep Out	Yes								
Sleep In	Yes								

14.1.6 Read Display MADCTL (0Bh)

Hex Code	Command	D/C	W/R	D7	D6	D5	D4	D3	D2	D1	D0	POR
R0Bh	RDDMADCTL	0	W	0	0	0	0	1	0	1	1	-
	1 st Parameter	1	R	0	0	0	0	BGR	0	SS	GS	00h

Description	-This command indicates the current status of the display as described in the table below:			
	Bit	Bit Symbol	Description	Value
	D7	Reserved	-	0
	D6	Reserved	-	0
	D5	Reserved	-	0
	D4	Reserved	-	0
	D3	BGR	RGB/BGR Order	'0' =RGB, '1' =BGR
	D2	Reserved	-	0
D1	SS	Flip Horizontal	'0' = Normal '1' = Flipped horizontally	
D0	GS	Flip Vertical	'0' = Normal '1' = Flipped vertically	
Restriction	-			
Register Availability	Status		Availability	
	Normal Mode On, Idle Mode Off, Sleep Out		Yes	
	Normal Mode On, Idle Mode On, Sleep Out		Yes	
	Sleep In		Yes	

14.1.7 Read Color format (0Ch)

Hex Code	Command	D/C	W/R	D7	D6	D5	D4	D3	D2	D1	D0	POR
R0Ch	RDPIX	0	W	0	0	0	0	1	1	0	0	-
	1 st Parameter	1	R	0	0	0	0	0	DBI[2:0]			07h

Description	-This command read pixel color format.	
Restriction	-	
Register Availability	Status	
	Normal Mode On, Idle Mode Off, Sleep Out	
	Normal Mode On, Idle Mode On, Sleep Out	
	Sleep In	
	Availability	
	Yes	
	Yes	
	Yes	

Confidential

14.1.8 Read Display Image Mode (0Dh)

Hex Code	Command	D/C	W/R	D7	D6	D5	D4	D3	D2	D1	D0	POR
R0Dh	RDDIM	0	W	0	0	0	0	1	1	0	1	-
	1 st Parameter	1	R	0	0	INVON	0	0	0	0	0	00h

Description	-This command indicates the current status of the display as described in the table below:		
	Bit	Bit Symbol	Description
	D7	D7	Revered
	D6	D6	
	D5	INVON	Inversion On/Off
	Value		
	‘0’ = Inversion is Off. ‘1’ = Inversion is On.		
	D4	D4	Reserved
D3	D3		
D2	D2		
D1	D1		
D0	D0		
Restriction	-		
Register Availability	Status		Availability
	Normal Mode On, Idle Mode Off, Sleep Out		Yes
	Normal Mode On, Idle Mode On, Sleep Out		Yes
	Sleep In		Yes

14.1.9 Read Signal Mode (0Eh)

Hex Code	Command	D/C	W/R	D7	D6	D5	D4	D3	D2	D1	D0	POR
R0Eh	RDDIM	0	W	0	0	0	0	1	1	1	0	-
	1 st Parameter	1	R	TEON	TELOM	0	0	0	0	0	0	00h

Description	-This command indicates the current status of the display as described in the table below:		
	Bit	Bit Symbol	Description
	D7	TEON	Tearing Effect Line
	D6	TELOM	Tearing Effect Line Output Mode
	D5	D5	Revered
	D4	D4	
	D3	D3	
	D2	D2	
D1	D1		
D0	D0		
			Value
			'0' : Off '1' : On
			'0' : Mode 0 '1' : Mode 1
			'0'
Restriction	-		
Register Availability	Status		Availability
	Normal Mode On, Idle Mode Off, Sleep Out		Yes
	Normal Mode On, Idle Mode On, Sleep Out		Yes
	Sleep In		Yes

14.1.10 Read Signal Mode (0Fh)

Hex Code	Command	D/C	W/R	D7	D6	D5	D4	D3	D2	D1	D0	POR
R0Eh	RDDSDR	0	W	0	0	0	0	1	1	1	0	-
	1 st Parameter	1	R	NVLD	FUND	0	0	0	0	0	0	00h

Description	-This command indicates the current status of the display as described in the table below:			
	Bit	Bit Symbol	Description	Value
	D7	NVLD	NVM Loading Detection	'0': Not OK '1': OK
	D6	FUND	Functionality Detection	'0': Not OK '1': OK
	D5	D5	Revered	'0'
	D4	D4		
	D3	D3		
	D2	D2		
D1	D1			
D0	D0			
Restriction	-			
Register Availability	Status		Availability	
	Normal Mode On, Idle Mode Off, Sleep Out		Yes	
	Normal Mode On, Idle Mode On, Sleep Out		Yes	
	Sleep In		Yes	

14.1.11 Sleep In (10h)

Hex Code	Command	D/C	W/R	D7	D6	D5	D4	D3	D2	D1	D0	POR
R10h	SLPIN	C	W	0	0	0	1	0	0	0	0	-

Description	<ul style="list-style-type: none"> - This command causes the LCD module to enter the low power consumption mode. - In this mode the DC/DC converter is disabled, and panel scanning is stopped. 									
Restriction	<ul style="list-style-type: none"> - This command has no effect when module is already in sleep in mode. Sleep In Mode can only be exit by the Sleep Out Command (11H). - It will be necessary to wait 5msec before sending next command; this is to allow time for the supply voltages and clock circuits to stabilize. - It will be necessary to wait 120msec after sending Sleep Out command (when in Sleep In Mode) before Sleep In command can be sent. - During sleep in mode, display data needed to be re-written into RAM before sleep out. 									
Register Availability	<table border="1" style="width: 100%; border-collapse: collapse;"> <thead> <tr> <th style="width: 50%;">Status</th> <th style="width: 50%;">Availability</th> </tr> </thead> <tbody> <tr> <td>Normal Mode On, Idle Mode Off, Sleep Out</td> <td>Yes</td> </tr> <tr> <td>Normal Mode On, Idle Mode On, Sleep Out</td> <td>Yes</td> </tr> <tr> <td>Sleep In</td> <td>Yes</td> </tr> </tbody> </table>	Status	Availability	Normal Mode On, Idle Mode Off, Sleep Out	Yes	Normal Mode On, Idle Mode On, Sleep Out	Yes	Sleep In	Yes	
Status	Availability									
Normal Mode On, Idle Mode Off, Sleep Out	Yes									
Normal Mode On, Idle Mode On, Sleep Out	Yes									
Sleep In	Yes									

Confidential

14.1.12 Sleep Out (11h)

Hex Code	Command	D/C	W/R	D7	D6	D5	D4	D3	D2	D1	D0	POR
R11h	SLPOUT	C	W	0	0	0	1	0	0	0	1	-

Description	<ul style="list-style-type: none"> - This command turns off sleep mode. - In this mode the DC/DC converter is enabled, and panel scanning is started. 									
Restriction	<ul style="list-style-type: none"> - This command has no effect when module is already in sleep out mode. Sleep Out Mode can only be exit by the Sleep In Command (10H), SW Reset Command (01H) or HW Reset. - It will be necessary to wait 5msec before sending next command; this is to allow time for the supply voltages and clock circuits to stabilize. - It will be necessary to wait 120msec after sending Sleep In command (when in Sleep Out mode) before Sleep Out command can be sent. - During sleep in mode, display data needed to be re-written into RAM before sleep out. 									
Register Availability	<table border="1"> <thead> <tr> <th>Status</th> <th>Availability</th> </tr> </thead> <tbody> <tr> <td>Normal Mode On, Idle Mode Off, Sleep Out</td> <td>Yes</td> </tr> <tr> <td>Normal Mode On, Idle Mode On, Sleep Out</td> <td>Yes</td> </tr> <tr> <td>Sleep In</td> <td>Yes</td> </tr> </tbody> </table>	Status	Availability	Normal Mode On, Idle Mode Off, Sleep Out	Yes	Normal Mode On, Idle Mode On, Sleep Out	Yes	Sleep In	Yes	
Status	Availability									
Normal Mode On, Idle Mode Off, Sleep Out	Yes									
Normal Mode On, Idle Mode On, Sleep Out	Yes									
Sleep In	Yes									

Confidential

14.1.13 Normal Display Mode On (13h)

Hex Code	Command	D/C	W/R	D7	D6	D5	D4	D3	D2	D1	D0	POR
R13h	NORON	C	W	0	0	0	1	0	0	1	1	-

Description	- This command causes the display module to enter the Normal Mode.	
Restriction	-This command has no effect when Normal mode is already active.	
Register Availability	Status	
	Availability	
	Normal Mode On, Idle Mode Off, Sleep Out	Yes
	Normal Mode On, Idle Mode On, Sleep Out	Yes
	Sleep In	Yes

Confidential

14.1.14 Display Invert Mode Off (20h)

Hex Code	Command	D/C	W/R	D7	D6	D5	D4	D3	D2	D1	D0	POR
R20h	INVOFF	C	W	0	0	1	0	0	0	0	0	-

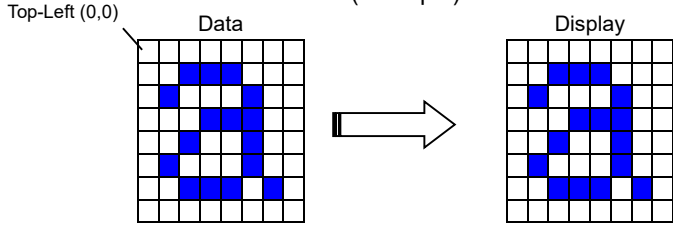
Description	<p>-This command is used to recover from display inversion mode. -This command does not change any other status.</p> <p>(Example)</p> 									
	Restriction	-This command has no effect when module is already inversion off mode.								
Register Availability	<table border="1"> <thead> <tr> <th>Status</th> <th>Availability</th> </tr> </thead> <tbody> <tr> <td>Normal Mode On, Idle Mode Off, Sleep Out</td> <td>Yes</td> </tr> <tr> <td>Normal Mode On, Idle Mode On, Sleep Out</td> <td>Yes</td> </tr> <tr> <td>Sleep In</td> <td>Yes</td> </tr> </tbody> </table>		Status	Availability	Normal Mode On, Idle Mode Off, Sleep Out	Yes	Normal Mode On, Idle Mode On, Sleep Out	Yes	Sleep In	Yes
Status	Availability									
Normal Mode On, Idle Mode Off, Sleep Out	Yes									
Normal Mode On, Idle Mode On, Sleep Out	Yes									
Sleep In	Yes									

14.1.15 Display Invert Mode On (21h)

Hex Code	Command	D/C	W/R	D7	D6	D5	D4	D3	D2	D1	D0	POR
R21h	INVON	C	W	0	0	1	0	0	0	0	1	-

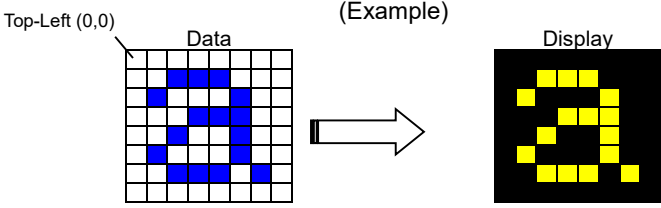
Description	<p>-This command is used to enter into display inversion mode -This command does not change any other status. -To exit from Display Inversion On, the Display Inversion Off command (20H) should be written.</p> <div style="text-align: center;">  </div>								
Restriction	<p>-This command has no effect when module is already Inversion On mode.</p>								
Register Availability	<table border="1" style="width: 100%; border-collapse: collapse;"> <thead> <tr> <th style="width: 50%;">Status</th> <th style="width: 50%;">Availability</th> </tr> </thead> <tbody> <tr> <td>Normal Mode On, Idle Mode Off, Sleep Out</td> <td style="text-align: center;">Yes</td> </tr> <tr> <td>Normal Mode On, Idle Mode On, Sleep Out</td> <td style="text-align: center;">Yes</td> </tr> <tr> <td style="text-align: center;">Sleep In</td> <td style="text-align: center;">Yes</td> </tr> </tbody> </table>	Status	Availability	Normal Mode On, Idle Mode Off, Sleep Out	Yes	Normal Mode On, Idle Mode On, Sleep Out	Yes	Sleep In	Yes
Status	Availability								
Normal Mode On, Idle Mode Off, Sleep Out	Yes								
Normal Mode On, Idle Mode On, Sleep Out	Yes								
Sleep In	Yes								

14.1.16 Display Off (28h)

Hex Code	Command	D/C	W/R	D7	D6	D5	D4	D3	D2	D1	D0	POR
R28h	DISPOFF	C	W	0	0	1	0	1	0	0	0	-

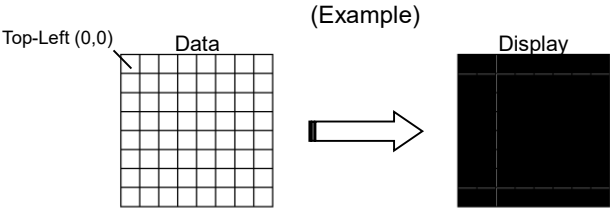
Description	<p>-This command is used to enter into DISPLAY OFF mode. - In this mode, the white or black image is displayed, which depends on the panel type. -This command does not change any other status. -There will be no abnormal visible effect on the display. -Exit from this command by Display On (29H)</p> <div style="text-align: center;">  <p>(Example)</p> </div>								
Restriction	-This command has no effect when module is already in display off mode.								
Register Availability	<table border="1" style="width: 100%; border-collapse: collapse;"> <thead> <tr> <th style="width: 50%;">Status</th> <th style="width: 50%;">Availability</th> </tr> </thead> <tbody> <tr> <td>Normal Mode On, Idle Mode Off, Sleep Out</td> <td style="text-align: center;">Yes</td> </tr> <tr> <td>Normal Mode On, Idle Mode On, Sleep Out</td> <td style="text-align: center;">Yes</td> </tr> <tr> <td style="text-align: center;">Sleep In</td> <td style="text-align: center;">Yes</td> </tr> </tbody> </table>	Status	Availability	Normal Mode On, Idle Mode Off, Sleep Out	Yes	Normal Mode On, Idle Mode On, Sleep Out	Yes	Sleep In	Yes
Status	Availability								
Normal Mode On, Idle Mode Off, Sleep Out	Yes								
Normal Mode On, Idle Mode On, Sleep Out	Yes								
Sleep In	Yes								

14.1.17 Display On (29h)

Hex Code	Command	D/C	RDX	D7	D6	D5	D4	D3	D2	D1	D0	POR
R29h	DISPON	C	1	0	0	1	0	1	0	0	1	-

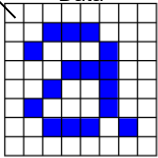
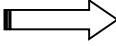
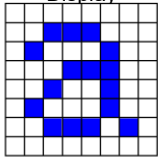
Description	<p>-This command is used to recover from DISPLAY OFF mode. -This command does not change any other status.</p> <p style="text-align: center;">(Example)</p> <div style="display: flex; align-items: center; justify-content: center;"> <div style="text-align: center;"> <p>Top-Left (0,0)</p>  <p>Data</p> </div> <div style="margin: 0 20px;">  </div> <div style="text-align: center;">  <p>Display</p> </div> </div>								
Restriction	-This command has no effect when module is already in display on mode.								
Register Availability	<table border="1" style="width: 100%; border-collapse: collapse;"> <thead> <tr> <th style="width: 50%;">Status</th> <th style="width: 50%;">Availability</th> </tr> </thead> <tbody> <tr> <td>Normal Mode On, Idle Mode Off, Sleep Out</td> <td>Yes</td> </tr> <tr> <td>Normal Mode On, Idle Mode On, Sleep Out</td> <td>Yes</td> </tr> <tr> <td>Sleep In</td> <td>Yes</td> </tr> </tbody> </table>	Status	Availability	Normal Mode On, Idle Mode Off, Sleep Out	Yes	Normal Mode On, Idle Mode On, Sleep Out	Yes	Sleep In	Yes
Status	Availability								
Normal Mode On, Idle Mode Off, Sleep Out	Yes								
Normal Mode On, Idle Mode On, Sleep Out	Yes								
Sleep In	Yes								

14.1.18Set Column (2AH)

Hex Code	Command	D/C	W/R	D7	D6	D5	D4	D3	D2	D1	D0	POR
R2Ah	SELCOL	C	W	0	0	1	0	1	0	1	0	-
	1st Parameter	D	W	SC[15:8]								00h
	2nd Parameter	D	W	SC[7:0]								00h
	3rd Parameter	D	W	EC[15:8]								01h
	4th Parameter	D	W	EC[7:0]								8Fh

Description	SC[15:0]: set start column EC[15:0]: set end column									
Restriction	- SC must be 4M, where M is integer - EC must be 4N-1, where N is integer									
Register Availability	<table border="1"> <thead> <tr> <th>Status</th> <th>Availability</th> </tr> </thead> <tbody> <tr> <td>Normal Mode On, Idle Mode Off, Sleep Out</td> <td>Yes</td> </tr> <tr> <td>Normal Mode On, Idle Mode On, Sleep Out</td> <td>Yes</td> </tr> <tr> <td>Sleep In</td> <td>Yes</td> </tr> </tbody> </table>		Status	Availability	Normal Mode On, Idle Mode Off, Sleep Out	Yes	Normal Mode On, Idle Mode On, Sleep Out	Yes	Sleep In	Yes
Status	Availability									
Normal Mode On, Idle Mode Off, Sleep Out	Yes									
Normal Mode On, Idle Mode On, Sleep Out	Yes									
Sleep In	Yes									

14.1.19Set Row (2BH)

Hex Code	Command	D/C	W/R	D7	D6	D5	D4	D3	D2	D1	D0	POR
R2Bh	SELPAGE	C	W	0	0	1	0	1	0	1	1	-
	1st Parameter	D	W	SP[15:8]								00h
	2nd Parameter	D	W	SP[7:0]								00h
	3rd Parameter	D	W	EP[15:8]								01h
	4th Parameter	D	W	EP[7:0]								8Fh

Description	SP[15:0]: set start row EP[15:0]: set end row									
Restriction	-									
Register Availability	<table border="1"> <thead> <tr> <th>Status</th> <th>Availability</th> </tr> </thead> <tbody> <tr> <td>Normal Mode On, Idle Mode Off, Sleep Out</td> <td>Yes</td> </tr> <tr> <td>Normal Mode On, Idle Mode On, Sleep Out</td> <td>Yes</td> </tr> <tr> <td>Sleep In</td> <td>Yes</td> </tr> </tbody> </table>	Status	Availability	Normal Mode On, Idle Mode Off, Sleep Out	Yes	Normal Mode On, Idle Mode On, Sleep Out	Yes	Sleep In	Yes	
Status	Availability									
Normal Mode On, Idle Mode Off, Sleep Out	Yes									
Normal Mode On, Idle Mode On, Sleep Out	Yes									
Sleep In	Yes									

Confidential

14.1.20 Write memory start (2CH)

Hex Code	Command	D/C	W/R	D7	D6	D5	D4	D3	D2	D1	D0	POR
R2Ch	WRMEMST	C	W	0	0	1	0	1	1	0	0	-

Description	Start to write memory data									
Restriction	<ul style="list-style-type: none"> - Cannot write whole frame data using 0x2C. - Separate whole frame into several segment. Use 0x2C and 0x3C to write whole frame data. 									
Register Availability	<table border="1" style="width: 100%; border-collapse: collapse;"> <thead> <tr> <th style="width: 50%;">Status</th> <th style="width: 50%;">Availability</th> </tr> </thead> <tbody> <tr> <td>Normal Mode On, Idle Mode Off, Sleep Out</td> <td>Yes</td> </tr> <tr> <td>Normal Mode On, Idle Mode On, Sleep Out</td> <td>Yes</td> </tr> <tr> <td>Sleep In</td> <td>Yes</td> </tr> </tbody> </table>		Status	Availability	Normal Mode On, Idle Mode Off, Sleep Out	Yes	Normal Mode On, Idle Mode On, Sleep Out	Yes	Sleep In	Yes
Status	Availability									
Normal Mode On, Idle Mode Off, Sleep Out	Yes									
Normal Mode On, Idle Mode On, Sleep Out	Yes									
Sleep In	Yes									

Confidential

14.1.21 Set Tearing Off (34H)

Hex Code	Command	D/C	W/R	D7	D6	D5	D4	D3	D2	D1	D0	POR
R34h	TEOFF	C	W	0	0	1	1	0	1	0	0	-

Description	- This command turns off the Tearing effect output signal from the TE signal line	
Restriction	- This command has no effect when Tearing Effect output is already off.	
Register Availability	Status	Availability
	Normal Mode On, Idle Mode Off, Sleep Out	Yes
	Normal Mode On, Idle Mode On, Sleep Out	Yes
	Sleep In	Yes

Confidential

14.1.22Set Tearing On(35H)

Hex Code	Command	D/C	W/R	D7	D6	D5	D4	D3	D2	D1	D0	POR
R35h	TEON	C	W	0	0	1	1	0	1	0	1	-
	1 st Parameter	D	W	0	0	0	0	0	0	0	TELOM	00h

Description	- This command turns on the Tearing effect output signal from the TE signal line.									
Restriction	- This command has no effect when Tearing Effect output is already off. - Changes in parameter TELOM is enabled form the next frame period.									
Register Availability	<table border="1"> <thead> <tr> <th>Status</th> <th>Availability</th> </tr> </thead> <tbody> <tr> <td>Normal Mode On, Idle Mode Off, Sleep Out</td> <td>Yes</td> </tr> <tr> <td>Normal Mode On, Idle Mode On, Sleep Out</td> <td>Yes</td> </tr> <tr> <td>Sleep In</td> <td>Yes</td> </tr> </tbody> </table>	Status	Availability	Normal Mode On, Idle Mode Off, Sleep Out	Yes	Normal Mode On, Idle Mode On, Sleep Out	Yes	Sleep In	Yes	
Status	Availability									
Normal Mode On, Idle Mode Off, Sleep Out	Yes									
Normal Mode On, Idle Mode On, Sleep Out	Yes									
Sleep In	Yes									

Confidential

14.1.23 Data Access Control (36H)

Hex Code	Command	D/C	W/R	D7	D6	D5	D4	D3	D2	D1	D0	POR
R36h	MADCTR	C	W	0	0	1	1	0	1	1	0	-
	1 st Parameter	D	W	0	0	0	0	RGB	0	SS	GS	00h

-This command defines write scanning direction from the host processor.

Bit	Bit Symbol	Description	Value
D7	Revered	-	0
D6	Revered	-	0
D5	Revered	-	0
D4	Revered	-	0
D3	BGR	RGB/BGR Order	'0' =RGB, '1' =BGR
D2	Revered	-	0
D1	SS	Flip Horizontal	'0' = Normal '1' = Flipped horizontally
D0	GS	Flip Vertical	'0' = Normal '1' = Flipped vertically

Description

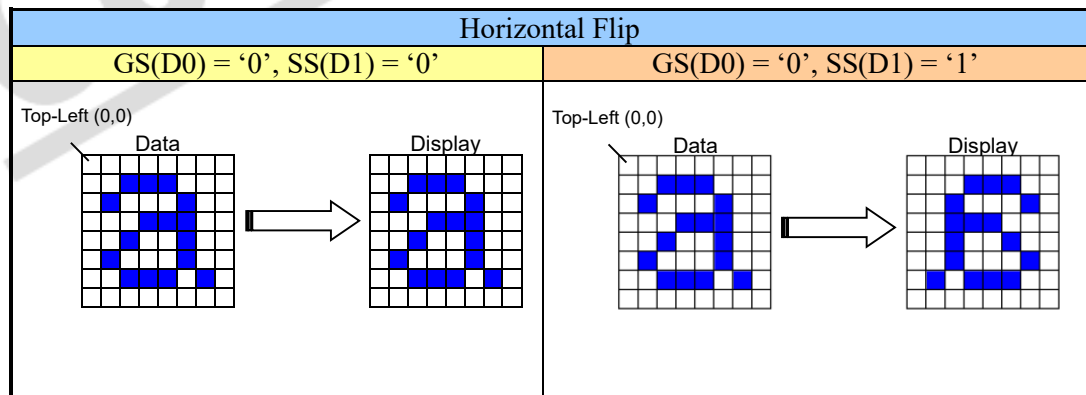
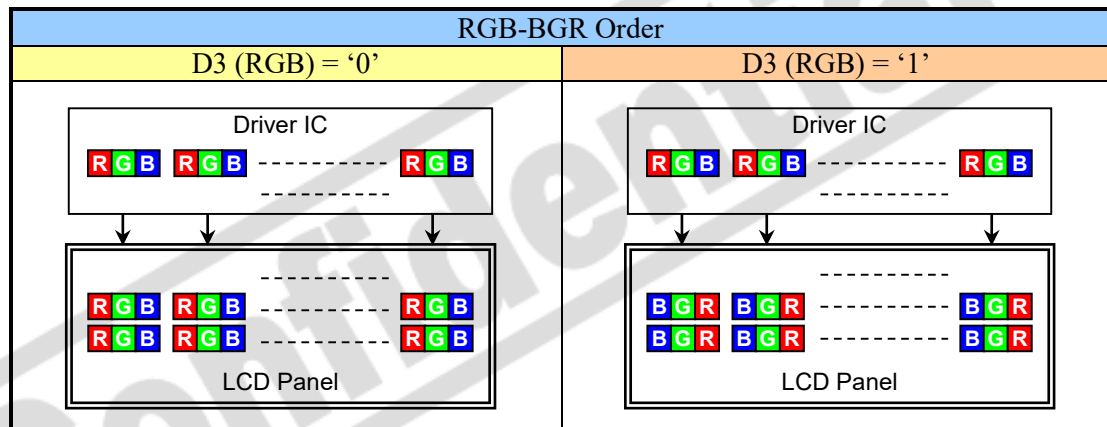

Description	Vertical Flip									
	GS(D0) = '0', SS(D1) = '0'	GS(D0) = '1', SS(D1) = '0'								
	<p>Top-Left (0,0)</p>	<p>Top-Left (0,0)</p>								
	Vertical & Horizontal Flip									
	GS(D0) = '0', SS(D1) = '0'	GS(D0) = '1', SS(D1) = '1'								
	<p>Top-Left (0,0)</p>	<p>Top-Left (0,0)</p>								
Register Availability	<table border="1"> <thead> <tr> <th>Status</th> <th>Availability</th> </tr> </thead> <tbody> <tr> <td>Normal Mode On, Idle Mode Off, Sleep Out</td> <td>Yes</td> </tr> <tr> <td>Normal Mode On, Idle Mode On, Sleep Out</td> <td>Yes</td> </tr> <tr> <td>Sleep In</td> <td>Yes</td> </tr> </tbody> </table>		Status	Availability	Normal Mode On, Idle Mode Off, Sleep Out	Yes	Normal Mode On, Idle Mode On, Sleep Out	Yes	Sleep In	Yes
Status	Availability									
Normal Mode On, Idle Mode Off, Sleep Out	Yes									
Normal Mode On, Idle Mode On, Sleep Out	Yes									
Sleep In	Yes									

14.1.24 Idle Mode Off (38H)

Hex Code	Command	D/C	W/R	D7	D6	D5	D4	D3	D2	D1	D0	POR
R38h	IDMOFF	C	W	0	0	1	1	1	0	0	0	-

Description	-This command is used to recover from Idle mode on.									
Restriction	- This command has no effect when module is already in idle off mode.									
Register Availability	<table border="1"> <thead> <tr> <th>Status</th> <th>Availability</th> </tr> </thead> <tbody> <tr> <td>Normal Mode On, Idle Mode Off, Sleep Out</td> <td>Yes</td> </tr> <tr> <td>Normal Mode On, Idle Mode On, Sleep Out</td> <td>Yes</td> </tr> <tr> <td>Sleep In</td> <td>Yes</td> </tr> </tbody> </table>	Status	Availability	Normal Mode On, Idle Mode Off, Sleep Out	Yes	Normal Mode On, Idle Mode On, Sleep Out	Yes	Sleep In	Yes	
Status	Availability									
Normal Mode On, Idle Mode Off, Sleep Out	Yes									
Normal Mode On, Idle Mode On, Sleep Out	Yes									
Sleep In	Yes									

Confidential

14.1.26 Idle Mode On (39H)

Hex Code	Command	D/C	W/R	D7	D6	D5	D4	D3	D2	D1	D0	POR
R39h	IDMON	C	W	0	0	1	1	1	0	0	1	-

Description	<p>- This command is used to enter into Idle mode on.</p> <p>- In the idle on mode, color expression is reduced. The primary and the secondary colors using MSB of each R, G and B in the Frame Memory, 8 color depth data is displayed.</p> <p>(Example)</p>																																				
	<table border="1"> <thead> <tr> <th>Color</th> <th>R₇ R₆ R₅ R₄ R₃ R₂ R₁ R₀</th> <th>G₇ G₆ G₅ G₄ G₃ G₂ G₁ G₀</th> <th>B₇ B₆ B₅ B₄ B₃ B₂ B₁ B₀</th> </tr> </thead> <tbody> <tr> <td>Black</td> <td>0xxxxxxx</td> <td>0xxxxxxx</td> <td>0xxxxxxx</td> </tr> <tr> <td>Blue</td> <td>0xxxxxxx</td> <td>0xxxxxxx</td> <td>1xxxxxxx</td> </tr> <tr> <td>Red</td> <td>1xxxxxxx</td> <td>0xxxxxxx</td> <td>0xxxxxxx</td> </tr> <tr> <td>Magenta</td> <td>1xxxxxxx</td> <td>0xxxxxxx</td> <td>1xxxxxxx</td> </tr> <tr> <td>Green</td> <td>0xxxxxxx</td> <td>1xxxxxxx</td> <td>0xxxxxxx</td> </tr> <tr> <td>Cyan</td> <td>0xxxxxxx</td> <td>1xxxxxxx</td> <td>1xxxxxxx</td> </tr> <tr> <td>Yellow</td> <td>1xxxxxxx</td> <td>1xxxxxxx</td> <td>0xxxxxxx</td> </tr> <tr> <td>White</td> <td>1xxxxxxx</td> <td>1xxxxxxx</td> <td>1xxxxxxx</td> </tr> </tbody> </table>		Color	R ₇ R ₆ R ₅ R ₄ R ₃ R ₂ R ₁ R ₀	G ₇ G ₆ G ₅ G ₄ G ₃ G ₂ G ₁ G ₀	B ₇ B ₆ B ₅ B ₄ B ₃ B ₂ B ₁ B ₀	Black	0xxxxxxx	0xxxxxxx	0xxxxxxx	Blue	0xxxxxxx	0xxxxxxx	1xxxxxxx	Red	1xxxxxxx	0xxxxxxx	0xxxxxxx	Magenta	1xxxxxxx	0xxxxxxx	1xxxxxxx	Green	0xxxxxxx	1xxxxxxx	0xxxxxxx	Cyan	0xxxxxxx	1xxxxxxx	1xxxxxxx	Yellow	1xxxxxxx	1xxxxxxx	0xxxxxxx	White	1xxxxxxx	1xxxxxxx
Color	R ₇ R ₆ R ₅ R ₄ R ₃ R ₂ R ₁ R ₀	G ₇ G ₆ G ₅ G ₄ G ₃ G ₂ G ₁ G ₀	B ₇ B ₆ B ₅ B ₄ B ₃ B ₂ B ₁ B ₀																																		
Black	0xxxxxxx	0xxxxxxx	0xxxxxxx																																		
Blue	0xxxxxxx	0xxxxxxx	1xxxxxxx																																		
Red	1xxxxxxx	0xxxxxxx	0xxxxxxx																																		
Magenta	1xxxxxxx	0xxxxxxx	1xxxxxxx																																		
Green	0xxxxxxx	1xxxxxxx	0xxxxxxx																																		
Cyan	0xxxxxxx	1xxxxxxx	1xxxxxxx																																		
Yellow	1xxxxxxx	1xxxxxxx	0xxxxxxx																																		
White	1xxxxxxx	1xxxxxxx	1xxxxxxx																																		
Restriction	- This command has no effect when module is already in idle off mode.																																				
Register Availability	<table border="1"> <thead> <tr> <th>Status</th> <th>Availability</th> </tr> </thead> <tbody> <tr> <td>Normal Mode On, Idle Mode Off, Sleep Out</td> <td>Yes</td> </tr> <tr> <td>Normal Mode On, Idle Mode On, Sleep Out</td> <td>Yes</td> </tr> <tr> <td>Sleep In</td> <td>Yes</td> </tr> </tbody> </table>		Status	Availability	Normal Mode On, Idle Mode Off, Sleep Out	Yes	Normal Mode On, Idle Mode On, Sleep Out	Yes	Sleep In	Yes																											
Status	Availability																																				
Normal Mode On, Idle Mode Off, Sleep Out	Yes																																				
Normal Mode On, Idle Mode On, Sleep Out	Yes																																				
Sleep In	Yes																																				

14.1.27Set Color format (3Ah)

Hex Code	Command	D/C	W/R	D7	D6	D5	D4	D3	D2	D1	D0	POR
R3Ah	SETPIXEL	C	W	0	0	1	1	1	0	1	0	-
	1 st Parameter	D	W	0	1	1	1	0	DBI[2:0]			77h

Description	<p>-This command set pixel color format.</p> <p>DBI[2:-0]=7: 16.7M color DBI[2:-0]=6: 262k color DBI[2:-0]=5: 65k color</p>									
Restriction	-									
Register Availability	<table border="1"> <thead> <tr> <th>Status</th> <th>Availability</th> </tr> </thead> <tbody> <tr> <td>Normal Mode On, Idle Mode Off, Sleep Out</td> <td>Yes</td> </tr> <tr> <td>Normal Mode On, Idle Mode On, Sleep Out</td> <td>Yes</td> </tr> <tr> <td>Sleep In</td> <td>Yes</td> </tr> </tbody> </table>	Status	Availability	Normal Mode On, Idle Mode Off, Sleep Out	Yes	Normal Mode On, Idle Mode On, Sleep Out	Yes	Sleep In	Yes	
Status	Availability									
Normal Mode On, Idle Mode Off, Sleep Out	Yes									
Normal Mode On, Idle Mode On, Sleep Out	Yes									
Sleep In	Yes									

Confidential

14.1.28 Write memory Continue (3CH)

Hex Code	Command	D/C	W/R	D7	D6	D5	D4	D3	D2	D1	D0	POR
R3Ch	WRMEMCONT	C	W	0	0	1	1	1	1	0	0	-

Description	Continue to write memory data	
Restriction	-	
Register Availability	Status	Availability
	Normal Mode On, Idle Mode Off, Sleep Out	Yes
	Normal Mode On, Idle Mode On, Sleep Out	Yes
	Sleep In	Yes

Confidential

14.1.29Set Tear Scanline (44h)

Hex Code	Command	D/C	W/R	D7	D6	D5	D4	D3	D2	D1	D0	POR
R44h	TESS	C	W	0	1	0	0	0	1	0	0	-
	1 st parameter	D	W	STS[15:8]								00h
	2 nd parameter	D	W	STS[7:0]								00h

Description	This command turns on the Tearing effect output signal from the TE signal line.		
Restriction	This command takes effect on the frame following the current frame. Therefore, if the TE signal is already ON, TE signal is output according to the old set tear on and set tear scanline commands until the end of currently scanned frame.		
Register Availability	Status		Availability
	Normal Mode On, Idle Mode Off, Sleep Out		Yes
	Normal Mode On, Idle Mode On, Sleep Out		Yes
	Sleep In		Yes

Confidential

14.1.30 Get Scanline (45h)

Hex Code	Command	D/C	W/R	D7	D6	D5	D4	D3	D2	D1	D0	POR
R45h	RSS	C	W	0	1	0	0	0	1	0	1	-
	1 st parameter	D	R	GTS[15:8]								00h
	2 nd parameter	D	R	GTS[7:0]								00h

Description	The display module returns the current scan line. The first scan line of back porch period is defined as line 0.	
Restriction	-	
Register Availability	Status	Availability
	Normal Mode On, Idle Mode Off, Sleep Out	Yes
	Normal Mode On, Idle Mode On, Sleep Out	Yes
	Sleep In	Yes

Confidential

14.1.31 Write Display Brightness (51h)

Hex Code	Command	D/C	W/R	D7	D6	D5	D4	D3	D2	D1	D0	POR
R51h	SETBR	C	W	0	1	0	1	0	0	0	1	-
	1 st parameter	D	W	DBV[13:6]								00h
	2 nd parameter	D	W	0	0	DBV[5:0]						00h

Description	- This command is used to set the display brightness value.		
Restriction	-		
Register Availability	Status		Availability
	Normal Mode On, Idle Mode Off, Sleep Out		Yes
	Normal Mode On, Idle Mode On, Sleep Out		Yes
	Sleep In		Yes

Confidential

14.1.32 Set Display Brightness mode(53h)

Hex Code	Command	D/C	W/R	D7	D6	D5	D4	D3	D2	D1	D0	POR
R53h	SETMODE	C	W	0	1	0	1	0	0	1	1	-
	1 st parameter	D	W	0	0	BCTRL	0	DD	BL	0	0	00h

Description	This command is used to set the value of display brightness control.																																				
	<table border="1"> <thead> <tr> <th>Bit</th> <th>Bit Symbol</th> <th>Description</th> </tr> </thead> <tbody> <tr> <td>D7</td> <td>D7</td> <td rowspan="2">Reserved</td> </tr> <tr> <td>D6</td> <td>D6</td> </tr> <tr> <td>D5</td> <td>BCTRL</td> <td>Brightness Control Block On/Off, This bit is always used to switch brightness for display 0 = Off 1 = On When this bit is set to off, the setting on DBV(51h) will be ignored. The PWM duty will be controlled only by CABC function.</td> </tr> <tr> <td>D4</td> <td>D4</td> <td>Reserved</td> </tr> <tr> <td>D3</td> <td>DD</td> <td>Display Dimming (DD): (Only for manual brightness setting) 0 = Off 1 = On: This bit is used to enable/disable PWM dimming function. When this bit is set to "1", the PWM duty will change from existing value to the target value (DBV) in a constant speed while the transition timing is control by the field "BCB" of command 0xC8.</td> </tr> <tr> <td>D2</td> <td>BL</td> <td>BL: Backlight Control On/Off 0 = Off (Completely turn off backlight circuit. Control lines must be low.) 1 = On</td> </tr> <tr> <td>D1</td> <td>D1</td> <td rowspan="2">Reserved</td> </tr> <tr> <td>D0</td> <td>D0</td> </tr> </tbody> </table>												Bit	Bit Symbol	Description	D7	D7	Reserved	D6	D6	D5	BCTRL	Brightness Control Block On/Off, This bit is always used to switch brightness for display 0 = Off 1 = On When this bit is set to off, the setting on DBV(51h) will be ignored. The PWM duty will be controlled only by CABC function.	D4	D4	Reserved	D3	DD	Display Dimming (DD): (Only for manual brightness setting) 0 = Off 1 = On: This bit is used to enable/disable PWM dimming function. When this bit is set to "1", the PWM duty will change from existing value to the target value (DBV) in a constant speed while the transition timing is control by the field "BCB" of command 0xC8.	D2	BL	BL: Backlight Control On/Off 0 = Off (Completely turn off backlight circuit. Control lines must be low.) 1 = On	D1	D1	Reserved	D0	D0
	Bit	Bit Symbol	Description																																		
	D7	D7	Reserved																																		
	D6	D6																																			
	D5	BCTRL	Brightness Control Block On/Off, This bit is always used to switch brightness for display 0 = Off 1 = On When this bit is set to off, the setting on DBV(51h) will be ignored. The PWM duty will be controlled only by CABC function.																																		
	D4	D4	Reserved																																		
	D3	DD	Display Dimming (DD): (Only for manual brightness setting) 0 = Off 1 = On: This bit is used to enable/disable PWM dimming function. When this bit is set to "1", the PWM duty will change from existing value to the target value (DBV) in a constant speed while the transition timing is control by the field "BCB" of command 0xC8.																																		
D2	BL	BL: Backlight Control On/Off 0 = Off (Completely turn off backlight circuit. Control lines must be low.) 1 = On																																			
D1	D1	Reserved																																			
D0	D0																																				
Restriction	-																																				
Register Availability	Status						Availability																														
	Normal Mode On, Idle Mode Off, Sleep Out						Yes																														
	Normal Mode On, Idle Mode On, Sleep Out						Yes																														
	Sleep In						Yes																														

14.1.33 Read Display Brightness mode(54h)

Hex Code	Command	D/C	W/R	D7	D6	D5	D4	D3	D2	D1	D0	POR
R54h	RDMODE	C	W	0	1	0	1	0	1	0	0	-
	1 st parameter	D	R	0	0	BCTRL	0	DD	BL	0	0	00h

Description	This command returns the value of display brightness control.											
	Bit	Bit Symbol	Description									
	D7	D7	Reserved									
	D6	D6										
	D5	BCTRL	Brightness Control Block On/Off, This bit is always used to switch brightness for display 0 = Off 1 = On When this bit is set to off, the setting on DBV(51h) will be ignored. The PWM duty will be controlled only by CABC function.									
	D4	D4	Reserved									
	D3	DD	Display Dimming (DD): (Only for manual brightness setting) 0 = Off 1 = On: This bit is used to enable/disable PWM dimming function. When this bit is set to "1", the PWM duty will change from existing value to the target value (DBV) in a constant speed while the transition timing is control by the field "BCB" of command 0xC8.									
	D2	BL	BL: Backlight Control On/Off 0 = Off (Completely turn off backlight circuit. Control lines must be low.) 1 = On									
D1	D1	Reserved										
D0	D0											
Restriction	-											
Register Availability	Status						Availability					
	Normal Mode On, Idle Mode Off, Sleep Out						Yes					
	Normal Mode On, Idle Mode On, Sleep Out						Yes					
	Sleep In						Yes					

14.1.34Set CABC control (55h)

Hex Code	Command	D/C	W/R	D7	D6	D5	D4	D3	D2	D1	D0	POR
R55h	SETPWR	C	W	0	1	0	1	0	1	0	1	-
	1 st parameter	D	W	0	0	0	0	0	0	CABC[1:0]		00h

Description	This command set the power saving level.																														
	<table border="1"> <thead> <tr> <th>Bit</th> <th>Bit Symbol</th> <th>Description</th> </tr> </thead> <tbody> <tr> <td>D7</td> <td>D7</td> <td rowspan="7">Reserved</td> </tr> <tr> <td>D6</td> <td>D6</td> </tr> <tr> <td>D5</td> <td>D5</td> </tr> <tr> <td>D4</td> <td>D4</td> </tr> <tr> <td>D3</td> <td>D3</td> </tr> <tr> <td>D2</td> <td>D2</td> </tr> <tr> <td>D1</td> <td rowspan="2">CABC[1:0]</td> <td rowspan="2"> '00' = Disable '01' = low '10' = middle '11' = high </td> </tr> <tr> <td>D0</td> </tr> </tbody> </table>												Bit	Bit Symbol	Description	D7	D7	Reserved	D6	D6	D5	D5	D4	D4	D3	D3	D2	D2	D1	CABC[1:0]	'00' = Disable '01' = low '10' = middle '11' = high
Bit	Bit Symbol	Description																													
D7	D7	Reserved																													
D6	D6																														
D5	D5																														
D4	D4																														
D3	D3																														
D2	D2																														
D1	CABC[1:0]		'00' = Disable '01' = low '10' = middle '11' = high																												
D0																															
Restriction	-																														
Register Availability	Status						Availability																								
	Normal Mode On, Idle Mode Off, Sleep Out						Yes																								
	Normal Mode On, Idle Mode On, Sleep Out						Yes																								
	Sleep In						Yes																								

14.1.35 Read CABC control (56h)

Hex Code	Command	D/C	W/R	D7	D6	D5	D4	D3	D2	D1	D0	POR
R56h	RDPWR	C	W	0	1	0	1	0	1	1	0	-
	1 st parameter	D	R	0	0	0	0	0	0	CABC[1:0]		00h

Description	This command returns the power saving level.																														
	<table border="1"> <thead> <tr> <th>Bit</th> <th>Bit Symbol</th> <th>Description</th> </tr> </thead> <tbody> <tr> <td>D7</td> <td>D7</td> <td rowspan="7">Reserved</td> </tr> <tr> <td>D6</td> <td>D6</td> </tr> <tr> <td>D5</td> <td>D5</td> </tr> <tr> <td>D4</td> <td>D4</td> </tr> <tr> <td>D3</td> <td>D3</td> </tr> <tr> <td>D2</td> <td>D2</td> </tr> <tr> <td>D1</td> <td rowspan="2">CABC[1:0]</td> <td rowspan="2">'00' = Disable '01' = low '10' = middle '11' = high</td> </tr> <tr> <td>D0</td> </tr> </tbody> </table>												Bit	Bit Symbol	Description	D7	D7	Reserved	D6	D6	D5	D5	D4	D4	D3	D3	D2	D2	D1	CABC[1:0]	'00' = Disable '01' = low '10' = middle '11' = high
Bit	Bit Symbol	Description																													
D7	D7	Reserved																													
D6	D6																														
D5	D5																														
D4	D4																														
D3	D3																														
D2	D2																														
D1	CABC[1:0]		'00' = Disable '01' = low '10' = middle '11' = high																												
D0																															
Restriction	-																														
Register Availability	Status						Availability																								
	Normal Mode On, Idle Mode Off, Sleep Out						Yes																								
	Normal Mode On, Idle Mode On, Sleep Out						Yes																								
	Sleep In						Yes																								

14.1.36Set CABC Minimum Brightness (5Eh)

Hex Code	Command	D/C	R/W	D7	D6	D5	D4	D3	D2	D1	D0	POR
R5Eh	SETMINBR	C	W	0	1	0	1	1	1	1	0	-
	1 st parameter	D	W	CMB[13:6]								
	1 nd parameter	D	W	0	0	CMB[5:0]						00h

Description	This command set CABC minimum brightness.	
Restriction	-	
Register Availability	Status	Availability
	Normal Mode On, Idle Mode Off, Sleep Out	Yes
	Normal Mode On, Idle Mode On, Sleep Out	Yes
	Sleep In	Yes

Confidential

14.1.37 Read CABC Minimum Brightness (5Fh)

Hex Code	Command	D/C	R/W	D7	D6	D5	D4	D3	D2	D1	D0	POR
R5Fh	RDMINBR	C	W	0	1	0	1	1	1	1	1	-
	1 st parameter	D	R	CMB[13:6]								
	2 nd parameter	D	R	0	0	CMB[5:0]					00h	

Description	This command returns CABC minimum brightness.	
Restriction	-	
Register Availability	Status	Availability
	Normal Mode On, Idle Mode Off, Sleep Out	Yes
	Normal Mode On, Idle Mode On, Sleep Out	Yes
	Sleep In	Yes

Confidential

14.1.38 Read DDB Start (A1h)

Hex Code	Command	D/C	R/W	D7	D6	D5	D4	D3	D2	D1	D0	POR
RA1h	RDDDBS	C	W	1	0	1	0	0	0	0	1	-
	1 st parameter	D	R	SID[7:0]								00h
	2 nd parameter	D	R	SID[15:8]								00h
	3 rd parameter	D	R	MID[7:0]								00h
	4 th parameter	D	R	MID[15:8]								00h
	5 th parameter	D	R	RID[7:0]								00h
	6 th parameter	D	R	RID[15:8]								00h

Description	Start to read manufacturer ID		
	Parameter	Code	Description
	1 st Parameter	SID[7:0]	Upper Byte of SSL ID code
	2 nd Parameter	SID[15:8]	Lower Byte of SSL ID code
	3 rd Parameter	MID[7:0]	Upper Byte of Manufacturer version
	4 th Parameter	MID[15:8]	Lower Byte of Manufacturer version
	5 th Parameter	RID [7:0]	SSL INTERNAL USED
	6 th Parameter	RID [15:8]	SSL INTERNAL USED
Restriction	-		
Register Availability	Status		Availability
	Normal Mode On, Idle Mode Off, Sleep Out		Yes
	Normal Mode On, Idle Mode On, Sleep Out		Yes
	Sleep In		Yes

14.1.39 Read DDB Continue (A8h)

Hex Code	Command	D/C	R/W	D7	D6	D5	D4	D3	D2	D1	D0	POR
RA8h	RDDDBCON	C	W	1	0	1	0	1	0	0	0	-
	1 st parameter	D	R	SID[7:0]								00h
	2 nd parameter	D	R	SID[15:8]								00h
	3 rd parameter	D	R	MID[7:0]								00h
	4 th parameter	D	R	MID[15:8]								00h
	5 th parameter	D	R	RID[7:0]								00h
	6 th parameter	D	R	RID[15:8]								00h

Description	Continue to read manufacturer ID		
	Parameter	Code	Description
	1 st Parameter	SID[7:0]	Upper Byte of SSL ID code
	2 nd Parameter	SID[15:8]	Lower Byte of SSL ID code
	3 rd Parameter	MID[7:0]	Upper Byte of Manufacturer version
	4 th Parameter	MID[15:8]	Lower Byte of Manufacturer version
	5 th Parameter	RID [7:0]	SSL INTERNAL USED
6 th Parameter	RID [15:8]	SSL INTERNAL USED	
Restriction	-		
Register Availability	Status		Availability
	Normal Mode On, Idle Mode Off, Sleep Out		Yes
	Normal Mode On, Idle Mode On, Sleep Out		Yes
	Sleep In		Yes

15 POWER ON/OFF SEQUENCES

Figure 15-1: Power On/Off Sequence

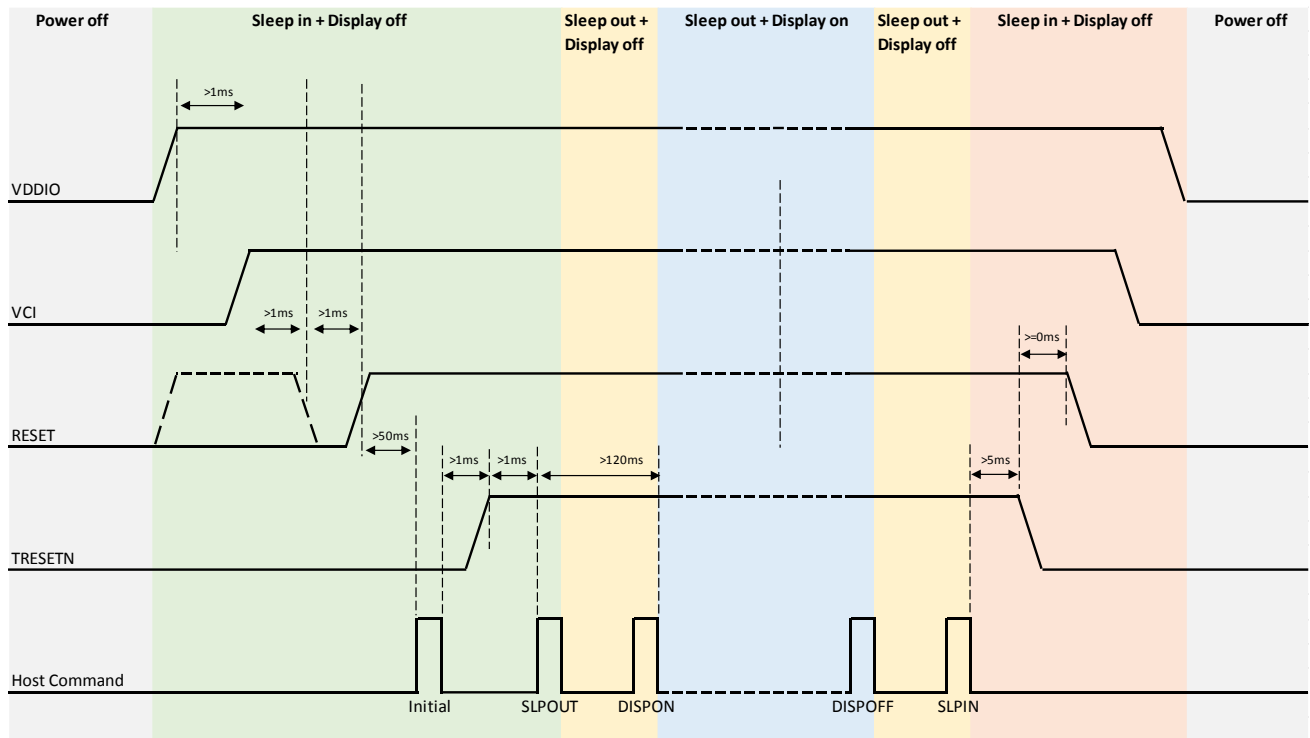

Confidential

16 OTP PROGRAM FLOW CHART

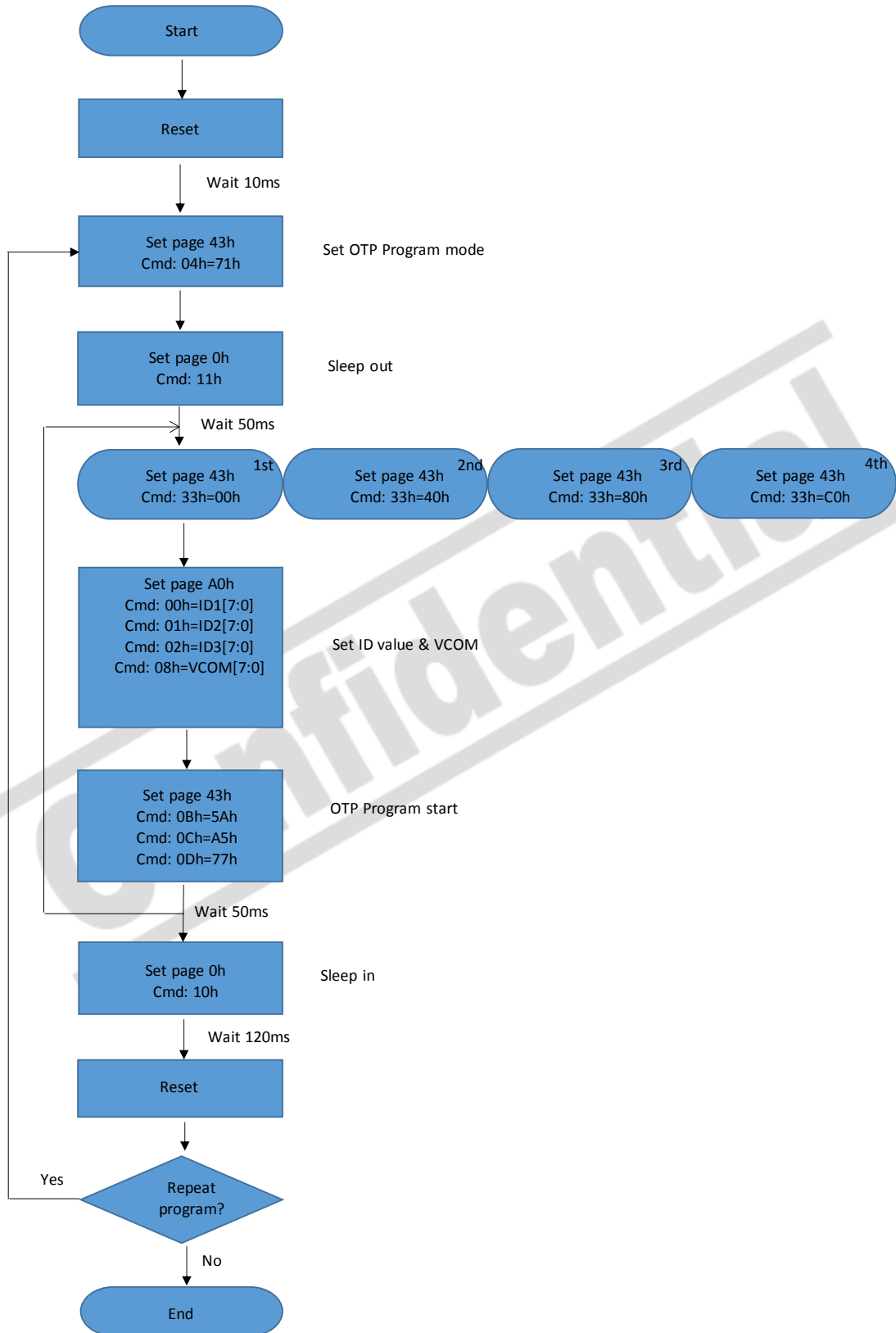

17 PACKAGE INFORMATION

17.1 Chip Tray Information

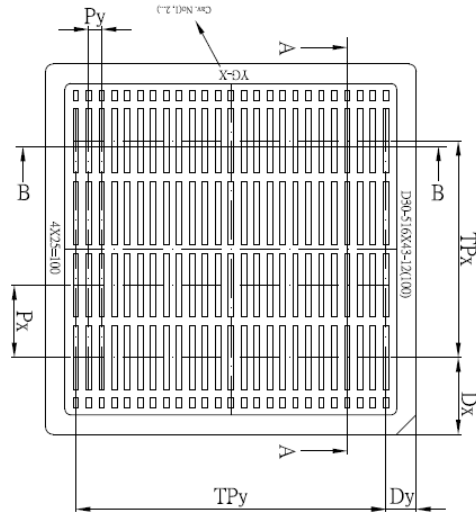
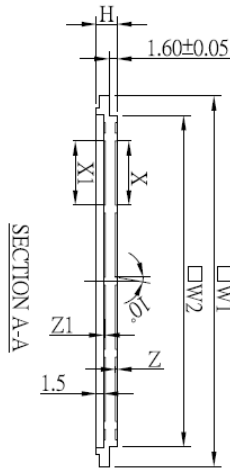

	Spec
W1	76.00±0.10 (2992)
W2	68.00±0.10 (2677)
W3	64.50±0.10 (2539)
H	4.20±0.10 (165)
Px	14.80±0.05 (583)
Py	2.65±0.05 (104)
Dx	15.80±0.05 (622)
Dy	44.00±0.10 (1734)
TPx	63.60±0.10 (2504)
X	13.10±0.05 (516)
Y	1.09±0.05 (43)
Z	0.30±0.05 (12)
X1	13.10±0.05 (516)
Y1	1.09±0.05 (43)
Z1	0.30±0.05 (12)
N	100 (pocket number)

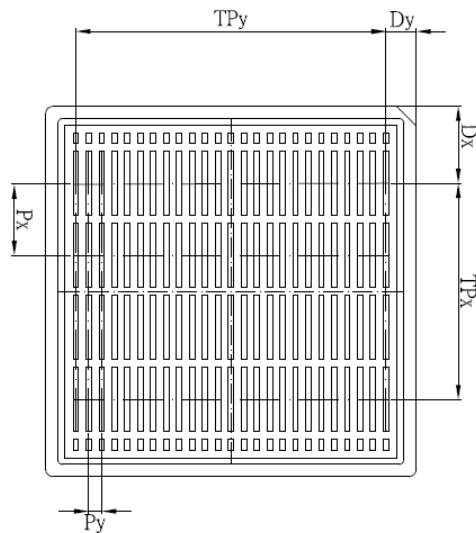
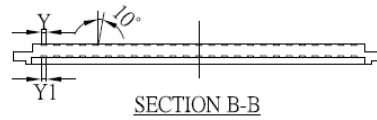

- Remark:
1. Tray material : ABS
 2. Tray color code: Black
 3. Tray warpage: Max. ± 0.1mm
 4. Surface resistance: $10^7 \sim 10^9 \Omega/\text{sq}$
 5. Pocket size(top side): 13.104 x1.098 x 0.30 mm
 6. Pocket size(bottom side): 13.104 x1.098 x 0.30 mm
 7. Bump face down
 8. Chip size: 13.004 x0.998 x 0.20 mm (with scribe line)
 9. Bottom of pocket: Rough surface

Confidential

Solomon Systech reserves the right to make changes without notice to any products herein. Solomon Systech makes no warranty, representation or guarantee regarding the suitability of its products for any particular purpose, nor does Solomon Systech assume any liability arising out of the application or use of any product or circuit, and specifically disclaims any, and all, liability, including without limitation consequential or incidental damages. "Typical" parameters can and do vary in different applications. All operating parameters, including "Typical" must be validated for each customer application by the customer's technical experts. Solomon Systech does not convey any license under its patent rights nor the rights of others. Solomon Systech products are not designed, intended, or authorized for use as components in systems intended for surgical implant into the body, or other applications intended to support or sustain life, or for any other application in which the failure of the Solomon Systech product could create a situation where personal injury or death may occur. Should Buyer purchase or use Solomon Systech products for any such unintended or unauthorized application, Buyer shall indemnify and hold Solomon Systech and its offices, employees, subsidiaries, affiliates, and distributors harmless against all claims, costs, damages, and expenses, and reasonable attorney fees arising out of, directly or indirectly, any claim of personal injury or death associated with such unintended or unauthorized use, even if such claim alleges that Solomon Systech was negligent regarding the design or manufacture of the part.



The product(s) listed in this datasheet comply with Directive (EU) 2015/863 of 31 March 2015 amending Annex II to Directive 2011/65/EU of the European Parliament and of the Council as regards the list of restricted substances and People's Republic of China Electronic Industry Standard GB/T 26572-2011 "Requirements for concentration limits for certain hazardous substances in electronic information products (电子电器产品中限用物质的限用要求)". Hazardous Substances test report is available upon request.

<http://www.solomon-systech.com>