

Sitronix

zerocap  **芯零携**™

ST77903

**400RGB x 480 16.7M Color without Display Ram
Single-Chip TFT Controller/Driver**

Datasheet

Sitronix reserves the right to change the contents in this document without prior notice, please contact Sitronix to obtain the latest version of datasheet before placing your order. No responsibility is assumed by Sitronix for any infringement of patent or other rights of third parties which may result from its use.

© 2020 Sitronix Technology Corporation. All rights reserved.

Preliminarily 0.4

LIST OF CONTENT

1	GENERAL DESCRIPTION	5
2	FEATURES.....	6
3	PAD ARRANGEMENT	8
	3.1 Output Bump Dimension.....	8
	3.2 Bump Dimension	9
	3.3 Alignment Mark Dimension.....	10
	3.4 Chip Information	10
4	PAD ARRANGEMENT	11
5	BLOCK DIAGRAM	23
6	PIN DESCRIPTION.....	24
	6.1 Power Supply Pins.....	24
	6.2. Interface Logic Pins	24
	6.3. Driver Output Pins	25
	6.4. Test and Other Pins	26
2.	DRIVER ELECTRICAL CHARACTERISTICS.....	27
	2.1. Absolute Operation Range.....	27
	2.2. DC Characteristics	28
	2.2.1. DC Characteristics for Panel Driving	28
	2.3. AC Characteristics	29
	2.4. Power Consumption.....	31
	2.5. Quad-SPI Interface	32
	Write command mode.....	32
	Write pixel data.....	32
	Read command mode.....	33
	2.6. Color Format	34
	QSPI RGB888.....	34
	QSPI RGB666.....	34
	QSPI RGB565.....	34
	2.7. RGB Interface	35
	RGB Interface Selection	35
	RGB Color Format.....	35
	RGB Interface Definition.....	37
	RGB Interface Timing	38
	2.8. Reset Timing	40
	2.9. Power ON/OFF Sequence.....	42
	2.10. Uncontrolled Power OFF	43
	2.11. Power Flow Chart.....	43

2.12.	Voltage Generation	44
2.13.	Relationship about source voltage.....	44
3.	FUNCTION DESCRIPTION	45
3.1.	Tearing Effect	45
3.2.	Gamma Correction.....	46
4	NVM PROGRAMMING FLOW	51
5	APPLICATION NOTE.....	52
5.1..	Layout Resistance Suggestion.....	52
6.	COMMAND.....	53
6.1.	Command Table List.....	53
6.2.	Command Table 1	56
	NOP (00h).....	56
	SWRESET (01h): Software Reset.....	56
	RDDID (04h): Read Display ID	58
	RDDST (09h): Read Display Status.....	59
	RDDPM (0Ah): Read Display Power Mode	60
	RDDMADCTL (0Bh): Read Display MADCTL	61
	RDDCOLMOD (0Ch): Read Display Pixel Format	62
	RDDIM (0Dh): Read Display Image Mode.....	63
	RDDSM (0Eh): Read Display Signal Mode	64
	RDDSDR (0Fh): Read Display Self-Diagnostic Result	65
	RDFCS (Aah): Read First Checksum.....	65
	RDCFCS (Afh): Read Continue Checksum	66
	RDID1 (Dah): Read ID1.....	67
	RDID2 (DBh): Read ID2	67
	RDID3 (DCh): Read ID3	68
	SLPIN (10h): Sleep in.....	69
	SLPOUT (11h): Sleep Out.....	70
	INVOFF (20h): Display Inversion Off	72
	INVON (21h): Display Inversion On	73
	DISPOFF (28h): Display Off.....	74
	DISPON (29h): Display On.....	76
	IDMOFF (38h): Idle Mode Off.....	77
	IDMON (39h): Idle mode on	78
	MADCTL (36h): Memory Data Access Control.....	80
	MOLMOD (3Ah): Interface Pixel Format.....	83
	RAMWR (2Ch): Memory Write	84

	WRMEMC (3Ch): Write Memory Continue.....	85
	TEOFF (34h): Tearing Effect Line OFF	87
	TEON (35h): Tearing Effect Line On	88
	STE (44h): Write Tear Scanline	89
	TESLRD (45h): Read Scanline.....	91
	WRIDMC (90h): Write two-color idle Mode color	92
	RDIDMC (91h): Read two-color idle Mode color	93
	HS(60h): Horizontal SYNC Command	94
	VS(61h): Vertical SYNC Command	94
6.3.	Command Table 2	95
	CK (F0h): Command Key.....	95
	ECFC (B0h): Entry Code Function Control	96
	FRC1 (B1h): Frame Rate Control 1	97
	GSC (B2h): Gate Scan Control.....	97
	VDMDC (B3h): Video Mode Display Control	98
	TCMDC (B4h): Two color Mode Display Control	99
	BPC (B5h): Blank Porch Control.....	100
	DISCN(B6h): Display Function Control	100
	EMSET (B7h): Entry Mode Set	101
	PWR (C0h): Power Control.....	102
	PWR1 (C1h): Power Control 1	103
	PWR2 (C2h): Power Control 2.....	105
	PWR3 (C3h): Power Control 3.....	108
	VCOMCTL (C5h): Vcom Control.....	109
	VMF1 Offset (D6h): Vcom1 Offset 1.....	111
	VMF2 Offset (D7h): Vcom Offset 2.....	112
	PGC (E0h): Positive Gamma Control.....	113
	NGC (E1h): Negative Gamma Control	114
	ANAMODE (E5h): Analog System Control	115
	DTRCON (D9h): Dithering Control	117
	SRECON (DEh): SRE Control.....	118
	RLCMODE (C8h): Run-length Control	119
	RGBIF (A0h): RGB Interface Control.....	121
7	REVISION HISTORY	122

1 GENERAL DESCRIPTION

The ST77903 is a single-chip controller/driver for 16.7M-color, graphic type TFT-LCD. The 400-channel source driver has true 8-bit resolution, which generates 64 Gamma-corrected values by an internal D/A converter. The ST77903 is capable of connecting directly to an external microprocessor, and provides QSPI interface. In addition, because of the integrated power supply circuit necessary to drive liquid crystal; it is possible to make a display system with fewest components.

Preliminary

2 FEATURES

- Single chip TFT-LCD Controller/Driver without Display RAM
- Display Resolution:
 - 400*RGB (H) *480(V)
 - 360*RGB (H) *360(V)
 - 320*RGB (H) *320(V)
 - 280*RGB (H) *280(V)
 - 240*RGB (H) *240(V)
 - 128*RGB (H) *128(V)
- LCD Driver Output Circuits
 - Source Outputs: 400 RGB Channels
 - Support gate control signals to gate driver in the panel
- Display Colors (Color Mode)
 - Idle Mode:8-colors
 - 2-color idle mode(1-bpp RAM) (Picture maximum compression size < 4k bytes)
- Programmable Pixel Color Format (Color Depth) for Various Display Data Input Format
 - 24-bit/pixel: RGB=(888) 16.7M color
- Interface
 - QSPI Mode (Clock maximum = 50MHz)
 - Serial RGB (888, 666, 565)
- Display Features
 - 1Gamma (64 gray levels)
 - SRE Function(enhancement CR)
- On Chip Build-In Circuits
 - DC/DC Converter
 - Non-Volatile (NV) Memory to Store Initial Register Setting and Factory Default Value (Module ID, Module Version, etc.)
 - Adjustable VCOM Generation
 - Timing Controller
- Build-In NV Memory for LCD Initial Register Setting
 - OTP to store VCOM and ID1~ID3
- Driving Algorithm
 - 1-dot/2-dot Inversion
- Wide Supply Voltage Range
 - I/O Voltage (VDDI to DGND): 1.65V ~ 3.3V ($VDDI \leq VDD$)
In VCCBYPASS Mode: VDDI=1.8v
 - Voltage for Digital Circuit (VDD to DGND): 2.6V ~ 3.3V

- Voltage for Analog Circuit (VDDA to AGND): 2.6V ~ 3.3V
- On-Chip Power System
- VCOM Level: AGND
- COG Type
- 3 Stagger 11um
- Operate temperature range: -30°C to +85 °C
- Power saving modes
- Deep standby mode
- Sleep mode
- Low frame mode 15Hz
- Output Power
- Gamma(+) voltage range: 3.6V~6.6V
- Gamma(-) voltage range:-4.2V~-1.6V
- VGH voltage range:12.6V~15.5V
- VGL voltage range: -8.4V~-11.8V
- Others
- Zero-Cap (Gate <320), when gate>320 reserve capacitor for AVDD, AVEE, SVDD, SVEE on FPC.
- GIP + Dual-gate driving
- OTP
- The Source number must be a multiple of 8
- The Gate number must be a multiple of 2
- In Bust Mode, H-Porch must be had blanking

3 PAD ARRANGEMENT

3.1 Output Bump Dimension

Au bump height	9um
Au bump size	15umx75um Gate : GOL1~GOL11 GOR1~GOR11
	30umx75um (Pad1 to Pad162)

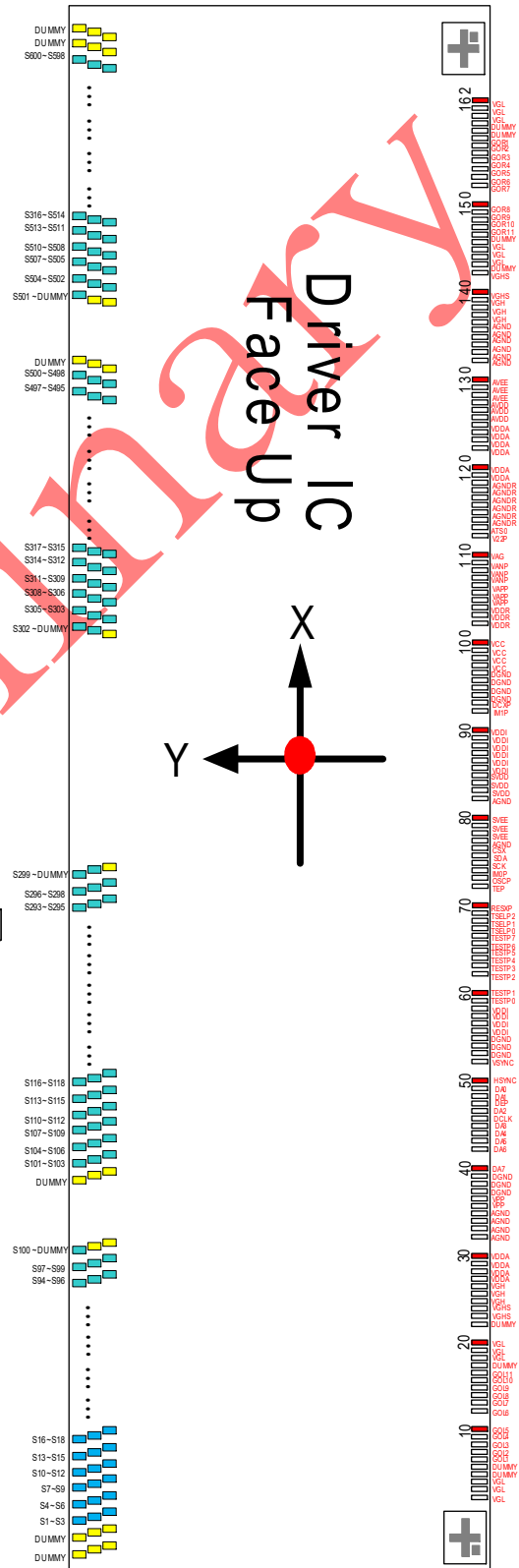
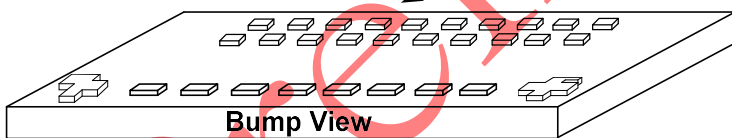

3.2 Bump Dimension

●Output Pads

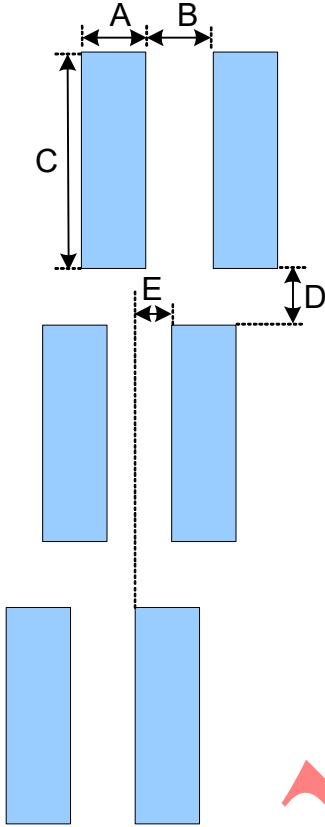

Symbol	Item	Size
A	Bump Width	15 um
B	Bump Gap 1 (Horizontal)	18 um
C	Bump Height	75 um
D	Bump Gap 2 (Vertical)	25 um
E	Bump Pitch	11um

●Input Pads

Pad No.1~162

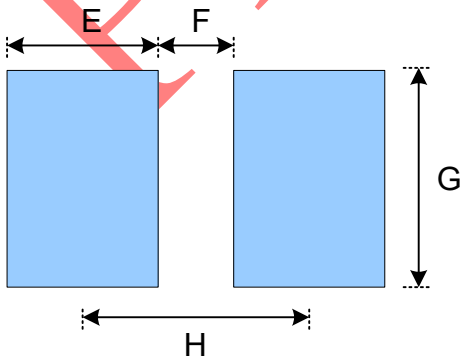

Symbol	Item	Size
E	Bump Width	30 um
F	Bump Gap	15 um
G	Bump Height	75 um
H	Bump Pitch	45 um

3.3 Alignment Mark Dimension

●Alignment Mark Left: L(X,Y)=(-3707, -352)

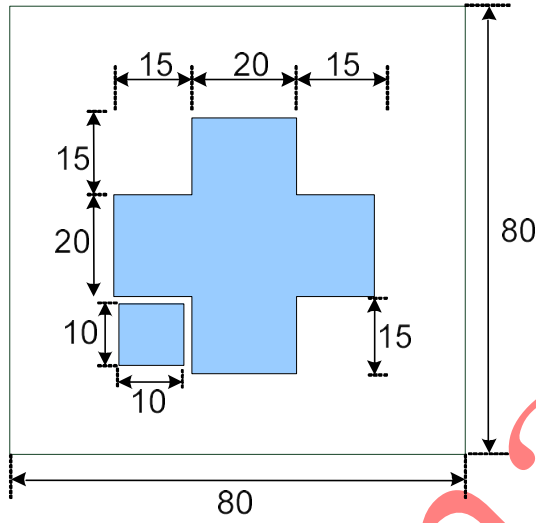

●Alignment Mark Right: R(X,Y)= (3707, -352)

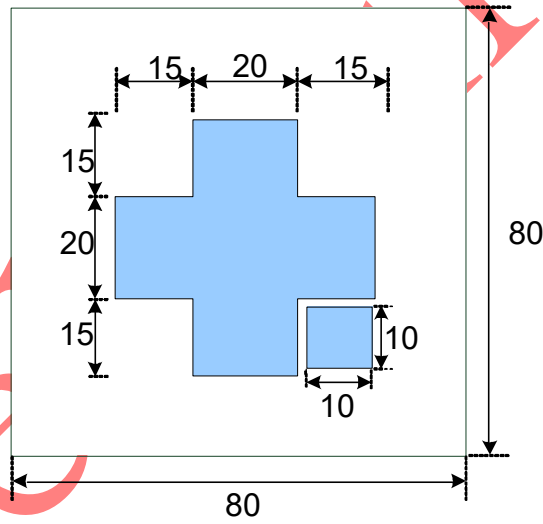

3.4 Chip Information

Chip size	um x um
Chip thickness	250um
Pad Location	Pad center
Coordinate Origin	Chip center

4 PAD ARRANGEMENT

PAD No.	PIN Name	X	Y	PAD No.	PIN Name	X	Y
1	VGL	-3622.5	-349.5	34	AGND	-2137.5	-349.5
2	VGL	-3577.5	-349.5	35	VPP	-2092.5	-349.5
3	VGL	-3532.5	-349.5	36	VPP	-2047.5	-349.5
4	DUMMY	-3487.5	-349.5	37	DGND	-2002.5	-349.5
5	DUMMY	-3442.5	-349.5	38	DGND	-1957.5	-349.5
6	GOL1	-3397.5	-349.5	39	DGND	-1912.5	-349.5
7	GOL2	-3352.5	-349.5	40	DA[7]	-1867.5	-349.5
8	GOL3	-3307.5	-349.5	41	DA[6]	-1822.5	-349.5
9	GOL4	-3262.5	-349.5	42	DA[5]	-1777.5	-349.5
10	GOL5	-3217.5	-349.5	43	DA[4]	-1732.5	-349.5
11	GOL6	-3172.5	-349.5	44	DA[3]	-1687.5	-349.5
12	GOL7	-3127.5	-349.5	45	DCLK	-1642.5	-349.5
13	GOL8	-3082.5	-349.5	46	DA[2]	-1597.5	-349.5
14	GOL9	-3037.5	-349.5	47	DEP	-1552.5	-349.5
15	GOL10	-2992.5	-349.5	48	DA[1]	-1507.5	-349.5
16	GOL11	-2947.5	-349.5	49	DA[0]	-1462.5	-349.5
17	DUMMY	-2902.5	-349.5	50	HSYNC	-1417.5	-349.5
18	VGL	-2857.5	-349.5	51	VSYNC	-1372.5	-349.5
19	VGL	-2812.5	-349.5	52	DGND	-1327.5	-349.5
20	VGL	-2767.5	-349.5	53	DGND	-1282.5	-349.5
21	DUMMY	-2722.5	-349.5	54	DGND	-1237.5	-349.5
22	VGHS	-2677.5	-349.5	55	VDDI	-1192.5	-349.5
23	VGHS	-2632.5	-349.5	56	VDDI	-1147.5	-349.5
24	VGHS	-2587.5	-349.5	57	VDDI	-1102.5	-349.5
25	VGHS	-2542.5	-349.5	58	VDDI	-1057.5	-349.5
26	VGHS	-2497.5	-349.5	59	TESTP0	-1012.5	-349.5
27	VDDA	-2452.5	-349.5	60	TESTP1	-967.5	-349.5
28	VDDA	-2407.5	-349.5	61	TESTP2	-922.5	-349.5
29	VDDA	-2362.5	-349.5	62	TESTP3	-877.5	-349.5
30	VDDA	-2317.5	-349.5	63	TESTP4	-832.5	-349.5
31	AGND	-2272.5	-349.5	64	TESTP5	-787.5	-349.5
32	AGND	-2227.5	-349.5	65	TESTP6	-742.5	-349.5
33	AGND	-2182.5	-349.5	66	TESTP7	-697.5	-349.5

PAD No.	PIN Name	X	Y	PAD No.	PIN Name	X	Y
67	TSELP0	-652.5	-349.5	101	VDDR	877.5	-349.5
68	TSELP1	-607.5	-349.5	102	VDDR	922.5	-349.5
69	TSELP2	-562.5	-349.5	103	VDDR	967.5	-349.5
70	RESXP	-517.5	-349.5	104	VAPP	1012.5	-349.5
71	TEP	-472.5	-349.5	105	VAPP	1057.5	-349.5
72	OSCP	-427.5	-349.5	106	VAPP	1102.5	-349.5
73	IM0P	-382.5	-349.5	107	VANP	1147.5	-349.5
74	SCKP	-337.5	-349.5	108	VANP	1192.5	-349.5
75	SDAP	-292.5	-349.5	109	VANP	1237.5	-349.5
76	CSXP	-247.5	-349.5	110	VAG	1282.5	-349.5
77	AGND	-202.5	-349.5	111	V22P	1327.5	-349.5
78	SVEE	-157.5	-349.5	112	ATS0	1372.5	-349.5
79	SVEE	-112.5	-349.5	113	AGNDR	1417.5	-349.5
80	SVEE	-67.5	-349.5	114	AGNDR	1462.5	-349.5
81	AGND	-22.5	-349.5	115	AGNDR	1507.5	-349.5
82	SVDD	22.5	-349.5	116	AGNDR	1552.5	-349.5
83	SVDD	67.5	-349.5	117	AGNDR	1597.5	-349.5
84	SVDD	112.5	-349.5	118	AGNDR	1642.5	-349.5
85	VDDI	157.5	-349.5	119	VDDA	1687.5	-349.5
86	VDDI	202.5	-349.5	120	VDDA	1732.5	-349.5
87	VDDI	247.5	-349.5	121	VDDA	1777.5	-349.5
88	VDDI	292.5	-349.5	122	VDDA	1822.5	-349.5
89	VDDI	337.5	-349.5	123	VDDA	1867.5	-349.5
90	VDDI	382.5	-349.5	124	VDDA	1912.5	-349.5
91	IM1P	427.5	-349.5	125	AVDD	1957.5	-349.5
92	DCXP	472.5	-349.5	126	AVDD	2002.5	-349.5
93	DGND	517.5	-349.5	127	AVDD	2047.5	-349.5
94	DGND	562.5	-349.5	128	AVEE	2092.5	-349.5
95	DGND	607.5	-349.5	129	AVEE	2137.5	-349.5
96	DGND	652.5	-349.5	130	AVEE	2182.5	-349.5
97	VCC	697.5	-349.5	131	AGND	2227.5	-349.5
98	VCC	742.5	-349.5	132	AGND	2272.5	-349.5
99	VCC	787.5	-349.5	133	AGND	2317.5	-349.5
100	VCC	832.5	-349.5	134	AGND	2362.5	-349.5

PAD No.	PIN Name	X	Y	PAD No.	PIN Name	X	Y
135	AGND	2407.5	-349.5	169	S600	3664	349.5
136	AGND	2452.5	-349.5	170	S599	3653	249.5
137	VGH	2497.5	-349.5	171	S598	3642	149.5
138	VGH	2542.5	-349.5	172	S597	3631	349.5
139	VGH	2587.5	-349.5	173	S596	3620	249.5
140	VGHS	2632.5	-349.5	174	S595	3609	149.5
141	VGHS	2677.5	-349.5	175	S594	3598	349.5
142	DUMMY	2722.5	-349.5	176	S593	3587	249.5
143	VGL	2767.5	-349.5	177	S592	3576	149.5
144	VGL	2812.5	-349.5	178	S591	3565	349.5
145	VGL	2857.5	-349.5	179	S590	3554	249.5
146	DUMMY	2902.5	-349.5	180	S589	3543	149.5
147	GOR11	2947.5	-349.5	181	S588	3532	349.5
148	GOR10	2992.5	-349.5	182	S587	3521	249.5
149	GOR9	3037.5	-349.5	183	S586	3510	149.5
150	GOR8	3082.5	-349.5	184	S585	3499	349.5
151	GOR7	3127.5	-349.5	185	S584	3488	249.5
152	GOR6	3172.5	-349.5	186	S583	3477	149.5
153	GOR5	3217.5	-349.5	187	S582	3466	349.5
154	GOR4	3262.5	-349.5	188	S581	3455	249.5
155	GOR3	3307.5	-349.5	189	S580	3444	149.5
156	GOR2	3352.5	-349.5	190	S579	3433	349.5
157	GOR1	3397.5	-349.5	191	S578	3422	249.5
158	DUMMY	3442.5	-349.5	192	S577	3411	149.5
159	DUMMY	3487.5	-349.5	193	S576	3400	349.5
160	VGL	3532.5	-349.5	194	S575	3389	249.5
161	VGL	3577.5	-349.5	195	S574	3378	149.5
162	VGL	3622.5	-349.5	196	S573	3367	349.5
163	DUMMY	3730	349.5	197	S572	3356	249.5
164	DUMMY	3719	249.5	198	S571	3345	149.5
165	DUMMY	3708	149.5	199	S570	3334	349.5
166	DUMMY	3697	349.5	200	S569	3323	249.5
167	DUMMY	3686	249.5	201	S568	3312	149.5
168	DUMMY	3675	149.5	202	S567	3301	349.5

PAD No.	PIN Name	X	Y	PAD No.	PIN Name	X	Y
203	S566	3290	249.5	237	S532	2916	149.5
204	S565	3279	149.5	238	S531	2905	349.5
205	S564	3268	349.5	239	S530	2894	249.5
206	S563	3257	249.5	240	S529	2883	149.5
207	S562	3246	149.5	241	S528	2872	349.5
208	S561	3235	349.5	242	S527	2861	249.5
209	S560	3224	249.5	243	S526	2850	149.5
210	S559	3213	149.5	244	S525	2839	349.5
211	S558	3202	349.5	245	S524	2828	249.5
212	S557	3191	249.5	246	S523	2817	149.5
213	S556	3180	149.5	247	S522	2806	349.5
214	S555	3169	349.5	248	S521	2795	249.5
215	S554	3158	249.5	249	S520	2784	149.5
216	S553	3147	149.5	250	S519	2773	349.5
217	S552	3136	349.5	251	S518	2762	249.5
218	S551	3125	249.5	252	S517	2751	149.5
219	S550	3114	149.5	253	S516	2740	349.5
220	S549	3103	349.5	254	S515	2729	249.5
221	S548	3092	249.5	255	S514	2718	149.5
222	S547	3081	149.5	256	S513	2707	349.5
223	S546	3070	349.5	257	S512	2696	249.5
224	S545	3059	249.5	258	S511	2685	149.5
225	S544	3048	149.5	259	S510	2674	349.5
226	S543	3037	349.5	260	S509	2663	249.5
227	S542	3026	249.5	261	S508	2652	149.5
228	S541	3015	149.5	262	S507	2641	349.5
229	S540	3004	349.5	263	S506	2630	249.5
230	S539	2993	249.5	264	S505	2619	149.5
231	S538	2982	149.5	265	S504	2608	349.5
232	S537	2971	349.5	266	S503	2597	249.5
233	S536	2960	249.5	267	S502	2586	149.5
234	S535	2949	149.5	268	S501	2575	349.5
235	S534	2938	349.5	269	DUMMY	2564	249.5
236	S533	2927	249.5	270	DUMMY	2553	149.5

PAD No.	PIN Name	X	Y	PAD No.	PIN Name	X	Y
271	DUMMY	2373	349.5	305	S469	1999	249.5
272	DUMMY	2362	249.5	306	S468	1988	149.5
273	DUMMY	2351	149.5	307	S467	1977	349.5
274	S500	2340	349.5	308	S466	1966	249.5
275	S499	2329	249.5	309	S465	1955	149.5
276	S498	2318	149.5	310	S464	1944	349.5
277	S497	2307	349.5	311	S463	1933	249.5
278	S496	2296	249.5	312	S462	1922	149.5
279	S495	2285	149.5	313	S461	1911	349.5
280	S494	2274	349.5	314	S460	1900	249.5
281	S493	2263	249.5	315	S459	1889	149.5
282	S492	2252	149.5	316	S458	1878	349.5
283	S491	2241	349.5	317	S457	1867	249.5
284	S490	2230	249.5	318	S456	1856	149.5
285	S489	2219	149.5	319	S455	1845	349.5
286	S488	2208	349.5	320	S454	1834	249.5
287	S487	2197	249.5	321	S453	1823	149.5
288	S486	2186	149.5	322	S452	1812	349.5
289	S485	2175	349.5	323	S451	1801	249.5
290	S484	2164	249.5	324	S450	1790	149.5
291	S483	2153	149.5	325	S449	1779	349.5
292	S482	2142	349.5	326	S448	1768	249.5
293	S481	2131	249.5	327	S447	1757	149.5
294	S480	2120	149.5	328	S446	1746	349.5
295	S479	2109	349.5	329	S445	1735	249.5
296	S478	2098	249.5	330	S444	1724	149.5
297	S477	2087	149.5	331	S443	1713	349.5
298	S476	2076	349.5	332	S442	1702	249.5
299	S475	2065	249.5	333	S441	1691	149.5
300	S474	2054	149.5	334	S440	1680	349.5
301	S473	2043	349.5	335	S439	1669	249.5
302	S472	2032	249.5	336	S438	1658	149.5
303	S471	2021	149.5	337	S437	1647	349.5
304	S470	2010	349.5	338	S436	1636	249.5

PAD No.	PIN Name	X	Y	PAD No.	PIN Name	X	Y
339	S435	1625	149.5	373	S401	1251	349.5
340	S434	1614	349.5	374	S400	1240	249.5
341	S433	1603	249.5	375	S399	1229	149.5
342	S432	1592	149.5	376	S398	1218	349.5
343	S431	1581	349.5	377	S397	1207	249.5
344	S430	1570	249.5	378	S396	1196	149.5
345	S429	1559	149.5	379	S395	1185	349.5
346	S428	1548	349.5	380	S394	1174	249.5
347	S427	1537	249.5	381	S393	1163	149.5
348	S426	1526	149.5	382	S392	1152	349.5
349	S425	1515	349.5	383	S391	1141	249.5
350	S424	1504	249.5	384	S390	1130	149.5
351	S423	1493	149.5	385	S389	1119	349.5
352	S422	1482	349.5	386	S388	1108	249.5
353	S421	1471	249.5	387	S387	1097	149.5
354	S420	1460	149.5	388	S386	1086	349.5
355	S419	1449	349.5	389	S385	1075	249.5
356	S418	1438	249.5	390	S384	1064	149.5
357	S417	1427	149.5	391	S383	1053	349.5
358	S416	1416	349.5	392	S382	1042	249.5
359	S415	1405	249.5	393	S381	1031	149.5
360	S414	1394	149.5	394	S380	1020	349.5
361	S413	1383	349.5	395	S379	1009	249.5
362	S412	1372	249.5	396	S378	998	149.5
363	S411	1361	149.5	397	S377	987	349.5
364	S410	1350	349.5	398	S376	976	249.5
365	S409	1339	249.5	399	S375	965	149.5
366	S408	1328	149.5	400	S374	954	349.5
367	S407	1317	349.5	401	S373	943	249.5
368	S406	1306	249.5	402	S372	932	149.5
369	S405	1295	149.5	403	S371	921	349.5
370	S404	1284	349.5	404	S370	910	249.5
371	S403	1273	249.5	405	S369	899	149.5
372	S402	1262	149.5	406	S368	888	349.5

PAD No.	PIN Name	X	Y	PAD No.	PIN Name	X	Y
407	S367	877	249.5	441	S333	503	149.5
408	S366	866	149.5	442	S332	492	349.5
409	S365	855	349.5	443	S331	481	249.5
410	S364	844	249.5	444	S330	470	149.5
411	S363	833	149.5	445	S329	459	349.5
412	S362	822	349.5	446	S328	448	249.5
413	S361	811	249.5	447	S327	437	149.5
414	S360	800	149.5	448	S326	426	349.5
415	S359	789	349.5	449	S325	415	249.5
416	S358	778	249.5	450	S324	404	149.5
417	S357	767	149.5	451	S323	393	349.5
418	S356	756	349.5	452	S322	382	249.5
419	S355	745	249.5	453	S321	371	149.5
420	S354	734	149.5	454	S320	360	349.5
421	S353	723	349.5	455	S319	349	249.5
422	S352	712	249.5	456	S318	338	149.5
423	S351	701	149.5	457	S317	327	349.5
424	S350	690	349.5	458	S316	316	249.5
425	S349	679	249.5	459	S315	305	149.5
426	S348	668	149.5	460	S314	294	349.5
427	S347	657	349.5	461	S313	283	249.5
428	S346	646	249.5	462	S312	272	149.5
429	S345	635	149.5	463	S311	261	349.5
430	S344	624	349.5	464	S310	250	249.5
431	S343	613	249.5	465	S309	239	149.5
432	S342	602	149.5	466	S308	228	349.5
433	S341	591	349.5	467	S307	217	249.5
434	S340	580	249.5	468	S306	206	149.5
435	S339	569	149.5	469	S305	195	349.5
436	S338	558	349.5	470	S304	184	249.5
437	S337	547	249.5	471	S303	173	149.5
438	S336	536	149.5	472	S302	162	349.5
439	S335	525	349.5	473	S301	151	249.5
440	S334	514	249.5	474	DUMMY	140	149.5

PAD No.	PIN Name	X	Y	PAD No.	PIN Name	X	Y
475	DUMMY	-140	149.5	509	S267	-514	249.5
476	S300	-151	249.5	510	S266	-525	349.5
477	S299	-162	349.5	511	S265	-536	149.5
478	S298	-173	149.5	512	S264	-547	249.5
479	S297	-184	249.5	513	S263	-558	349.5
480	S296	-195	349.5	514	S262	-569	149.5
481	S295	-206	149.5	515	S261	-580	249.5
482	S294	-217	249.5	516	S260	-591	349.5
483	S293	-228	349.5	517	S259	-602	149.5
484	S292	-239	149.5	518	S258	-613	249.5
485	S291	-250	249.5	519	S257	-624	349.5
486	S290	-261	349.5	520	S256	-635	149.5
487	S289	-272	149.5	521	S255	-646	249.5
488	S288	-283	249.5	522	S254	-657	349.5
489	S287	-294	349.5	523	S253	-668	149.5
490	S286	-305	149.5	524	S252	-679	249.5
491	S285	-316	249.5	525	S251	-690	349.5
492	S284	-327	349.5	526	S250	-701	149.5
493	S283	-338	149.5	527	S249	-712	249.5
494	S282	-349	249.5	528	S248	-723	349.5
495	S281	-360	349.5	529	S247	-734	149.5
496	S280	-371	149.5	530	S246	-745	249.5
497	S279	-382	249.5	531	S245	-756	349.5
498	S278	-393	349.5	532	S244	-767	149.5
499	S277	-404	149.5	533	S243	-778	249.5
500	S276	-415	249.5	534	S242	-789	349.5
501	S275	-426	349.5	535	S241	-800	149.5
502	S274	-437	149.5	536	S240	-811	249.5
503	S273	-448	249.5	537	S239	-822	349.5
504	S272	-459	349.5	538	S238	-833	149.5
505	S271	-470	149.5	539	S237	-844	249.5
506	S270	-481	249.5	540	S236	-855	349.5
507	S269	-492	349.5	541	S235	-866	149.5
508	S268	-503	149.5	542	S234	-877	249.5

PAD No.	PIN Name	X	Y	PAD No.	PIN Name	X	Y
543	S233	-888	349.5	577	S199	-1262	149.5
544	S232	-899	149.5	578	S198	-1273	249.5
545	S231	-910	249.5	579	S197	-1284	349.5
546	S230	-921	349.5	580	S196	-1295	149.5
547	S229	-932	149.5	581	S195	-1306	249.5
548	S228	-943	249.5	582	S194	-1317	349.5
549	S227	-954	349.5	583	S193	-1328	149.5
550	S226	-965	149.5	584	S192	-1339	249.5
551	S225	-976	249.5	585	S191	-1350	349.5
552	S224	-987	349.5	586	S190	-1361	149.5
553	S223	-998	149.5	587	S189	-1372	249.5
554	S222	-1009	249.5	588	S188	-1383	349.5
555	S221	-1020	349.5	589	S187	-1394	149.5
556	S220	-1031	149.5	590	S186	-1405	249.5
557	S219	-1042	249.5	591	S185	-1416	349.5
558	S218	-1053	349.5	592	S184	-1427	149.5
559	S217	-1064	149.5	593	S183	-1438	249.5
560	S216	-1075	249.5	594	S182	-1449	349.5
561	S215	-1086	349.5	595	S181	-1460	149.5
562	S214	-1097	149.5	596	S180	-1471	249.5
563	S213	-1108	249.5	597	S179	-1482	349.5
564	S212	-1119	349.5	598	S178	-1493	149.5
565	S211	-1130	149.5	599	S177	-1504	249.5
566	S210	-1141	249.5	600	S176	-1515	349.5
567	S209	-1152	349.5	601	S175	-1526	149.5
568	S208	-1163	149.5	602	S174	-1537	249.5
569	S207	-1174	249.5	603	S173	-1548	349.5
570	S206	-1185	349.5	604	S172	-1559	149.5
571	S205	-1196	149.5	605	S171	-1570	249.5
572	S204	-1207	249.5	606	S170	-1581	349.5
573	S203	-1218	349.5	607	S169	-1592	149.5
574	S202	-1229	149.5	608	S168	-1603	249.5
575	S201	-1240	249.5	609	S167	-1614	349.5
576	S200	-1251	349.5	610	S166	-1625	149.5

PAD No.	PIN Name	X	Y	PAD No.	PIN Name	X	Y
611	S165	-1636	249.5	645	S131	-2010	349.5
612	S164	-1647	349.5	646	S130	-2021	149.5
613	S163	-1658	149.5	647	S129	-2032	249.5
614	S162	-1669	249.5	648	S128	-2043	349.5
615	S161	-1680	349.5	649	S127	-2054	149.5
616	S160	-1691	149.5	650	S126	-2065	249.5
617	S159	-1702	249.5	651	S125	-2076	349.5
618	S158	-1713	349.5	652	S124	-2087	149.5
619	S157	-1724	149.5	653	S123	-2098	249.5
620	S156	-1735	249.5	654	S122	-2109	349.5
621	S155	-1746	349.5	655	S121	-2120	149.5
622	S154	-1757	149.5	656	S120	-2131	249.5
623	S153	-1768	249.5	657	S119	-2142	349.5
624	S152	-1779	349.5	658	S118	-2153	149.5
625	S151	-1790	149.5	659	S117	-2164	249.5
626	S150	-1801	249.5	660	S116	-2175	349.5
627	S149	-1812	349.5	661	S115	-2186	149.5
628	S148	-1823	149.5	662	S114	-2197	249.5
629	S147	-1834	249.5	663	S113	-2208	349.5
630	S146	-1845	349.5	664	S112	-2219	149.5
631	S145	-1856	149.5	665	S111	-2230	249.5
632	S144	-1867	249.5	666	S110	-2241	349.5
633	S143	-1878	349.5	667	S109	-2252	149.5
634	S142	-1889	149.5	668	S108	-2263	249.5
635	S141	-1900	249.5	669	S107	-2274	349.5
636	S140	-1911	349.5	670	S106	-2285	149.5
637	S139	-1922	149.5	671	S105	-2296	249.5
638	S138	-1933	249.5	672	S104	-2307	349.5
639	S137	-1944	349.5	673	S103	-2318	149.5
640	S136	-1955	149.5	674	S102	-2329	249.5
641	S135	-1966	249.5	675	S101	-2340	349.5
642	S134	-1977	349.5	676	DUMMY	-2351	149.5
643	S133	-1988	149.5	677	DUMMY	-2362	249.5
644	S132	-1999	249.5	678	DUMMY	-2373	349.5

PAD No.	PIN Name	X	Y	PAD No.	PIN Name	X	Y
679	DUMMY	-2553	149.5	713	S68	-2927	249.5
680	DUMMY	-2564	249.5	714	S67	-2938	349.5
681	S100	-2575	349.5	715	S66	-2949	149.5
682	S99	-2586	149.5	716	S65	-2960	249.5
683	S98	-2597	249.5	717	S64	-2971	349.5
684	S97	-2608	349.5	718	S63	-2982	149.5
685	S96	-2619	149.5	719	S62	-2993	249.5
686	S95	-2630	249.5	720	S61	-3004	349.5
687	S94	-2641	349.5	721	S60	-3015	149.5
688	S93	-2652	149.5	722	S59	-3026	249.5
689	S92	-2663	249.5	723	S58	-3037	349.5
690	S91	-2674	349.5	724	S57	-3048	149.5
691	S90	-2685	149.5	725	S56	-3059	249.5
692	S89	-2696	249.5	726	S55	-3070	349.5
693	S88	-2707	349.5	727	S54	-3081	149.5
694	S87	-2718	149.5	728	S53	-3092	249.5
695	S86	-2729	249.5	729	S52	-3103	349.5
696	S85	-2740	349.5	730	S51	-3114	149.5
697	S84	-2751	149.5	731	S50	-3125	249.5
698	S83	-2762	249.5	732	S49	-3136	349.5
699	S82	-2773	349.5	733	S48	-3147	149.5
700	S81	-2784	149.5	734	S47	-3158	249.5
701	S80	-2795	249.5	735	S46	-3169	349.5
702	S79	-2806	349.5	736	S45	-3180	149.5
703	S78	-2817	149.5	737	S44	-3191	249.5
704	S77	-2828	249.5	738	S43	-3202	349.5
705	S76	-2839	349.5	739	S42	-3213	149.5
706	S75	-2850	149.5	740	S41	-3224	249.5
707	S74	-2861	249.5	741	S40	-3235	349.5
708	S73	-2872	349.5	742	S39	-3246	149.5
709	S72	-2883	149.5	743	S38	-3257	249.5
710	S71	-2894	249.5	744	S37	-3268	349.5
711	S70	-2905	349.5	745	S36	-3279	149.5
712	S69	-2916	149.5	746	S35	-3290	249.5

PAD No.	PIN Name	X	Y	PAD No.	PIN Name	X	Y
747	S34	-3301	349.5	781	DUMMY	-3675	149.5
748	S33	-3312	149.5	782	DUMMY	-3686	249.5
749	S32	-3323	249.5	783	DUMMY	-3697	349.5
750	S31	-3334	349.5	784	DUMMY	-3708	149.5
751	S30	-3345	149.5	785	DUMMY	-3719	249.5
752	S29	-3356	249.5	786	DUMMY	-3730	349.5
753	S28	-3367	349.5				
754	S27	-3378	149.5				
755	S26	-3389	249.5				
756	S25	-3400	349.5				
757	S24	-3411	149.5				
758	S23	-3422	249.5				
759	S22	-3433	349.5				
760	S21	-3444	149.5				
761	S20	-3455	249.5				
762	S19	-3466	349.5				
763	S18	-3477	149.5				
764	S17	-3488	249.5				
765	S16	-3499	349.5				
766	S15	-3510	149.5				
767	S14	-3521	249.5				
768	S13	-3532	349.5				
769	S12	-3543	149.5				
770	S11	-3554	249.5				
771	S10	-3565	349.5				
772	S9	-3576	149.5				
773	S8	-3587	249.5				
774	S7	-3598	349.5				
775	S6	-3609	149.5				
776	S5	-3620	249.5				
777	S4	-3631	349.5				
778	S3	-3642	149.5				
779	S2	-3653	249.5				
780	S1	-3664	349.5				

5 BLOCK DIAGRAM

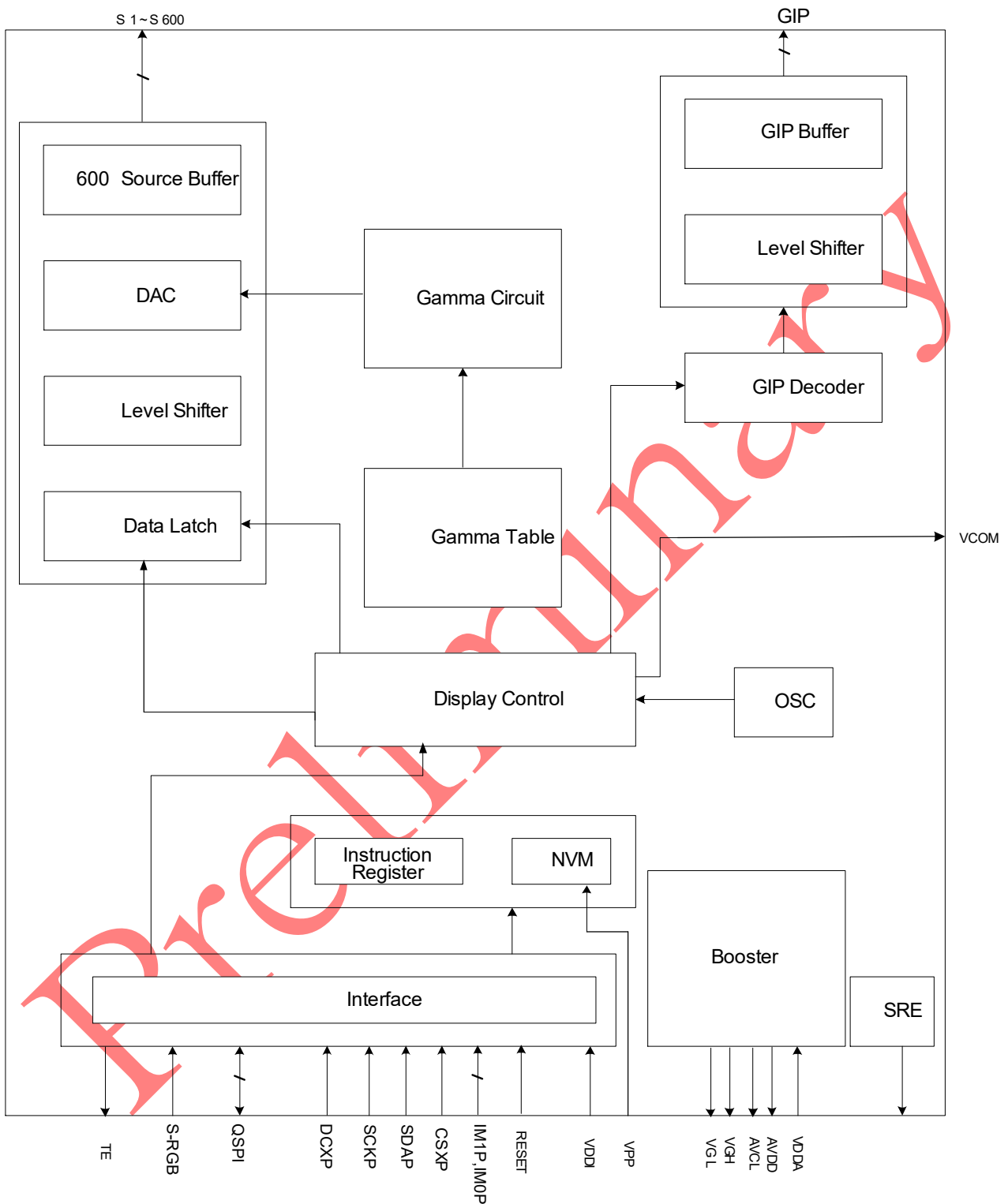

6 PIN DESCRIPTION

6.1 Power Supply Pins

Name	I/O	Description	Connect Pin
VDDI	I	- Power supply for I/O system. - VDDI must be lower than or equal to VDD.	VDDI
VDDA	I	- Power supply for analog and booster circuits. Input voltage level should be the same as VCI.	VCI
VDDR	I	- Power supply for Gamma circuits. Input voltage level should be the same as VCI.	VCI
AGND	I	- System ground for analog system and booster circuit.	GND
AGNDR	I	- System ground for Gamma circuit.	GND
DGND	I	- System ground for I/O system and digital system.	GND
VPP	I	- Power supply for internal NVM. - Writing NVM needs external power supply voltage with 7.5V. - The current of Ivpp must be more than 10mA. - Leaves these pins open if not used.	External Power

6.2. Interface Logic Pins

Name	I/O	Description	Connect Pin															
IMP	I	- MCU Parallel Interface Type Selection.	GND															
		<table border="1"> <thead> <tr> <th>IM1P</th> <th>IM0P</th> <th>Parallel Interface</th> </tr> </thead> <tbody> <tr> <td>0</td> <td>0</td> <td>Signal/Dual/Quad SPI</td> </tr> <tr> <td>0</td> <td>1</td> <td>Reverse</td> </tr> <tr> <td>1</td> <td>0</td> <td>3_SPI with Serial RGB</td> </tr> <tr> <td>1</td> <td>1</td> <td>4_SPI with Serial RGB</td> </tr> </tbody> </table>		IM1P	IM0P	Parallel Interface	0	0	Signal/Dual/Quad SPI	0	1	Reverse	1	0	3_SPI with Serial RGB	1	1	4_SPI with Serial RGB
		IM1P		IM0P	Parallel Interface													
		0		0	Signal/Dual/Quad SPI													
		0		1	Reverse													
1	0	3_SPI with Serial RGB																
1	1	4_SPI with Serial RGB																
RESXP	I	- This signal will reset the device and it must be applied to properly initialize the chip. - Signal is active low.	MCU															
DA[7,0]	I	-DA[3,0] : Q/O SPI Data pin. -S-RGB Data Pin	MCU															
CSXP	I	-Chip select pin. Low Enable.	MCU															
SCKP	I	-The serial input/output clock in serial interface mode	MCU															
SDAP	I	-The serial input/output signal in serial interface mode. -If not used, please fix this pin at VDDI or DGND level	MCU															

Name	I/O	Description	Connect Pin
DCXP	I	-Display data/command Selection Pin in MCU Interface. -D/CX='1': Display Data or Parameter. -D/CX='0': Command Data. -If not used, please fix this pin at VDDI or DGND level.	MCU
TEP	O	- Tearing effect output. - If not used, leave this pin open.	MCU
VSYNC	I	-Vertical (Frame) synchronizing input signal for RGB interface operation. -If not used, please fix to the VDDI or DGND.	MCU
HSYNC	I	-Horizontal (Line) synchronizing input signal for RGB interface operation. - If not used, please fix to VDDI or DGND.	MCU
DEP	I	-Data enable signal for RGB interface operation. -If not used, please fix this pin at VDDI or DGND.	MCU

6.3. Driver Output Pins

Name	I/O	Description	Connect pin
S[1:600]	O	Source output voltage signals applied to liquid crystal.	LCD
GOR[1:11] GOL[1:11]	O	Gate control signals and the swing voltage level is VGH to VGL.	LCD
VGH	O	- Power output pin for gate driver. - Leave open when not in use.	LCD
VGL	O	- Power output (Negative) pin for gate driver. - Leave open when not in use.	LCD
VGHS	O	- Power output pin for gate driver. (pump) - Leave open when not in use.	LCD

6.4. Test and Other Pins

Name	I/O	Description	Connect pin
Dummy	-	- These pins are dummy. - Leave the pin open.	OPEN
OSCP	I/O	- This pin is for testing. - Leave the pin open.	OPEN
HSTRIM	O	- This pin is for testing. - Leave the pin open.	OPEN
VCCM	O	-Used for monitoring. - Leave the pin open.	OPEN
VCCLP	O	Used for monitoring. - Leave the pin open.	OPEN
TSELP[0:2]	I	- This pin is for testing - Leave the pin open.	OPEN
SVEE	O	-Used for monitoring. - Leave the pin open.	OPEN
SVDD	O	-Used for monitoring. - Leave the pin open.	OPEN
VCC	O	-Used for monitoring. - Leave the pin open.	OPEN
AVDD	O	-Power Pad for analog Circuit. - Leave the pin open.	OPEN
AVEE	O	-Power Pad for analog Circuit. - Leave the pin open.	OPEN
VAPP	O	-A power output of grayscale voltage. - Leave the pin open.	OPEN
VANP	O	-A power output (negative) of gray scale voltage. - Leave the pin open.	OPEN
VAG	O	- This pin is for testing. - Leave the pin open.	OPEN
V22P	O	-Used for monitoring. - Leave the pin open.	OPEN
ATS0	O	- This pin is for testing. - Leave the pin open.	OPEN
TEST[0:7]	O	- This pin is for testing - Leave the pin open.	OPEN

7. DRIVER ELECTRICAL CHARACTERISTICS

7.1. Absolute Operation Range

Item	Symbol	Range	Unit
Supply Voltage (Analog)	VCI	- 0.3 ~ +4.6	V
Supply Voltage (I/O)	VDDI	- 0.3 ~ +4.6	V
Supply Voltage (Logic)	VCC	-0.3 ~ +2	V
Driver Supply Voltage	VGH-VGL	-0.3 ~ +30.0	V
Logic Input Voltage Range	VIN	0.5 ~ VDDI + 0.5	V
Logic Output Voltage Range	VO	0.5 ~ VDDI + 0.5	V
Operating Temperature Range	TOPR	-30 ~ +85	°C
Storage Temperature Range	TSTG	-40 ~ +125	°C

Absolute Operation Range

Note: If one of the above items is exceeded its maximum limitation momentarily, the quality of the product may be degraded. Absolute maximum limitation, therefore, specify the values exceeding which the product may be physically damaged. Be sure to use the product within the recommend range.

7.2. DC Characteristics

7.2.1. DC Characteristics for Panel Driving

Parameter	Symbol	Condition	Specification			Unit	Related Pins
			MIN.	TYP.	MAX.		
Power & Operation Voltage							
System Voltage	VDD / VDDA	Operating voltage	2.6	2.75	3.3	V	-
Interface Operation Voltage	VDDI	I/O Supply Voltage	1.65	1.8	3.3	V	-
Gate Driver High Voltage	VGH	-	12.6	-	15.5	V	-
Gate Driver Low Voltage	VGL	-	-11.8	-	-8.4	V	-
Gate Driver Supply Voltage	-	VGH-VGL	-	-	27.3	V	-
Input / Output							
Logic-High Input Voltage	VIH	-	0.7VDDI	-	VDDI	V	Note 1
Logic-Low Input Voltage	VIL	-	VSS	-	0.3VDDI	V	Note 1
Logic-High Output Voltage	VOH	IOH = -1.0mA	0.8VDDI	-	VDDI	V	Note 1
Logic-Low Output Voltage	VOL	IOL = +1.0mA	VSS	-	0.2VDDI	V	Note 1
Logic-High Input Current	I _{IH}	V _{IN} = VDDI	-	-	1	uA	Note 1
Logic-Low Input Current	I _{IL}	V _{IN} = VSS	-1	-	-	uA	Note 1
Input Leakage Current	ILI	IOH = -1.0mA	-0.1	-	+0.1	uA	Note 1
VCOM Voltage							
VCOM Voltage	VCOM	-	-	VSS	-	V	-
Source Driver							
Gamma Reference Voltage(Positive)	VAP	-	3.6	-	6.6	V	-
Gamma Reference Voltage(Negative)	VAN	-	-4.2	-	-1.6	-	-
Source Output Settling Time	Tr	Below with 99% precision	-	-	20	us	Note 2
Output Offset Voltage	VOFFSET	-	-	-	35	mV	Note 3

Basic DC Characteristics

Notes:

1. TA= -30 to 85 °C.

2. The max. value is between measured point of source output and gamma setting value.

7.3. AC Characteristics

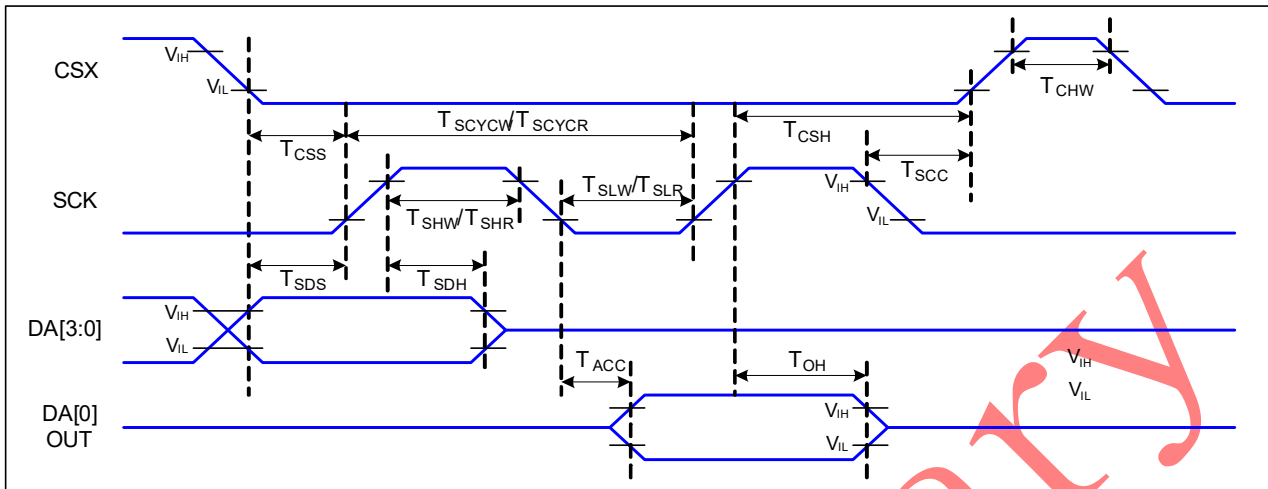

Figure 1 QSPI Interface Timing Characteristics

VDDI=1.65 to 3.3V, VDD=2.4 to 3.3V, AGND=DGND=0V, Ta=25 °C

Signal	Symbol	Parameter	Min	Max	Unit	Description
CSX	T _{CSS}	Chip select setup time (write)	19		ns	
	T _{CSH}	Chip select hold time (write)	19		ns	
	T _{CSS}	Chip select setup time (read)	60		ns	
	T _{SCC}	Chip select hold time (read)	65		ns	
	T _{CHW}	Chip select "H" pulse width	40		ns	
			500		ns	Note 1
SCL	T _{SCYCW}	Serial clock cycle (Write)	20		ns	
	T _{SHW}	SCL "H" pulse width (Write)	7		ns	
	T _{SLW}	SCL "L" pulse width (Write)	7		ns	
	T _{SCYCR}	Serial clock cycle (Read)	150		ns	
	T _{SHR}	SCL "H" pulse width (Read)	60		ns	
	T _{SLR}	SCL "L" pulse width (Read)	60		ns	
SDA (DIN)	T _{SDS}	Data setup time	7		ns	
	T _{SDH}	Data hold time	7		ns	
DOUT	T _{ACC}	Access time	10	50	ns	For maximum CL=30pF
	T _{OH}	Output disable time	TBD	TBD	ns	For minimum CL=8pF

Table 1 QSPI Interface Characteristics

Note : The rising time and falling time (Tr, Tf) of input signal are specified at 15 ns or less. Logic high and low levels are specified as 30% and 70% of VDDI for Input signals.

Note1 At display data (CMD 0x006000). When CSX go to “H”, must be wait over 500ns than CSX should be returned “L” level.

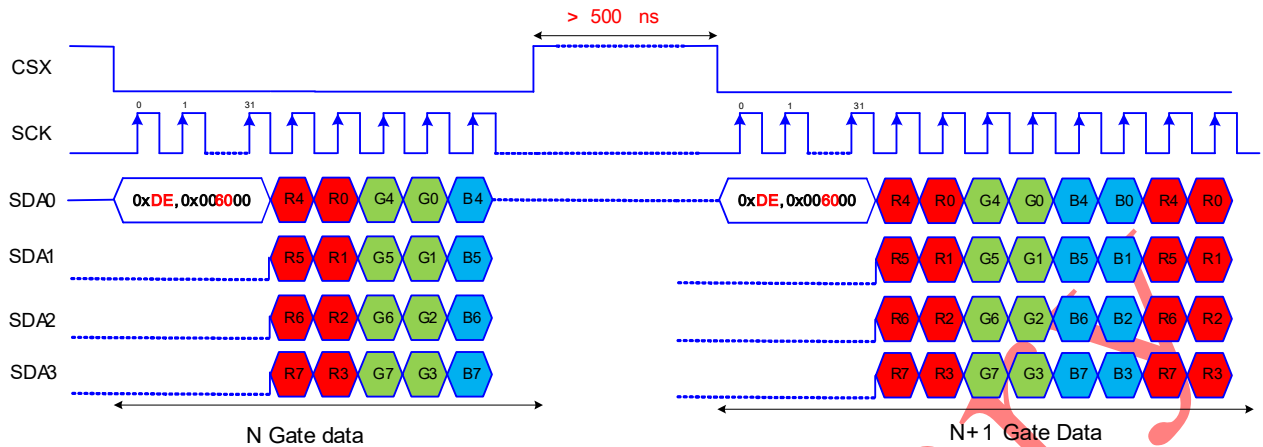

Minimum line time must be > 40us ; Vsync width and Vsync porch >40us

For example: In 60Hz, 320RGBx400 resolution. Vsync width=1, Vsync front+back porch=12

$$\text{Line time} = 16.67 / (400 + 1 + 12) = 40.363\mu\text{s}$$

This line time is fit minimum line time condition.

7.4. Power Consumption

Ta=25°C, Frame rate = 30Hz, Registers setting are IC default setting.

Operation Mode	Image	Current Consumption			
		Typical		Maximum	
		IDD (mA)	IDD (mA)	IDD (mA)	IDD (mA)
Normal Mode	Note	TBD	TBD	TBD	TBD
Sleep in Mode	Note	TBD	TBD	TBD	TBD
Standby Mode	Note	TBD	TBD	TBD	TBD

Notes:

1. Color Picture.
2. The Current Consumption is DC characteristics of ST77903.
3. Typical: VDDI=1.8V, VCI=2.8V; Maximum: VDDI=3.3V, VCI=3.3V
4. Maximum can not be used VCCM/VCC Bypass

7.5. Quad-SPI Interface

Pin Name	Description
SCKP	Clock signal (Max=50MHz)
DA0	Serial input data lane 0
DA1	Serial input data lane 1
DA2	Serial input data lane 2
DA3	Serial input data lane 3

Write command mode

When host writes commands or parameter to ST77903, host needs to send 1 byte of write command instruction (0xDE). Then host sends 3 bytes of AD[23:0] which is composed of 1 byte of 0x00, 1 byte of command address and 1 byte of 0x00. After host sending instruction and AD[23:0], the following data is parameter (are parameters). When the last bit of parameter has been sent, CSX pin should be returned "H" level.

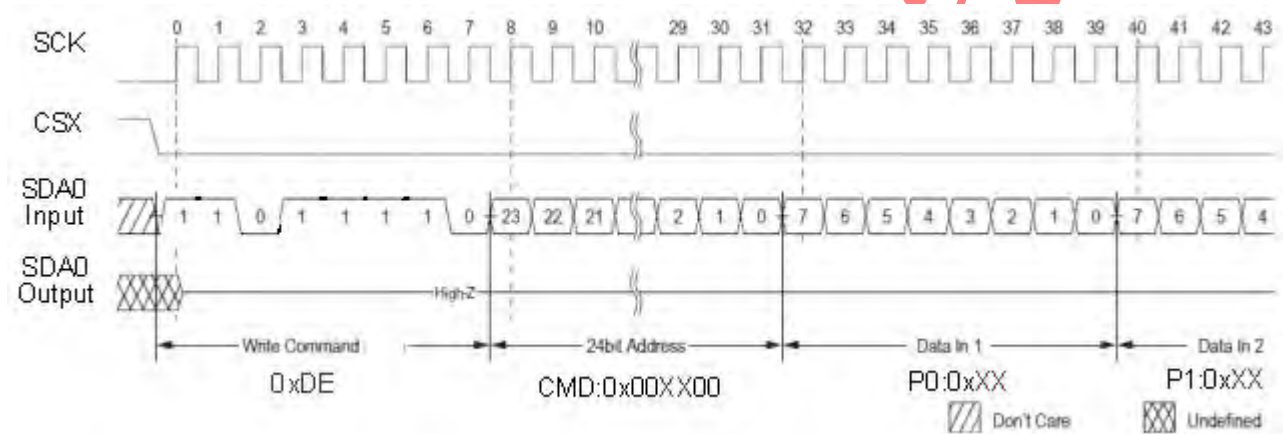

Write pixel data

In write pixel data mode, the host sends one byte of instruction, 3 byte of AD[23:0] and pixel data. The instruction is transferred only by one lane of DA0, and data can be transferred 4 DA lanes.

The 0xDE+0x006100 must be issued at the beginning of each frame. The 0xDE+0x006000 must be issued at the beginning of each line.

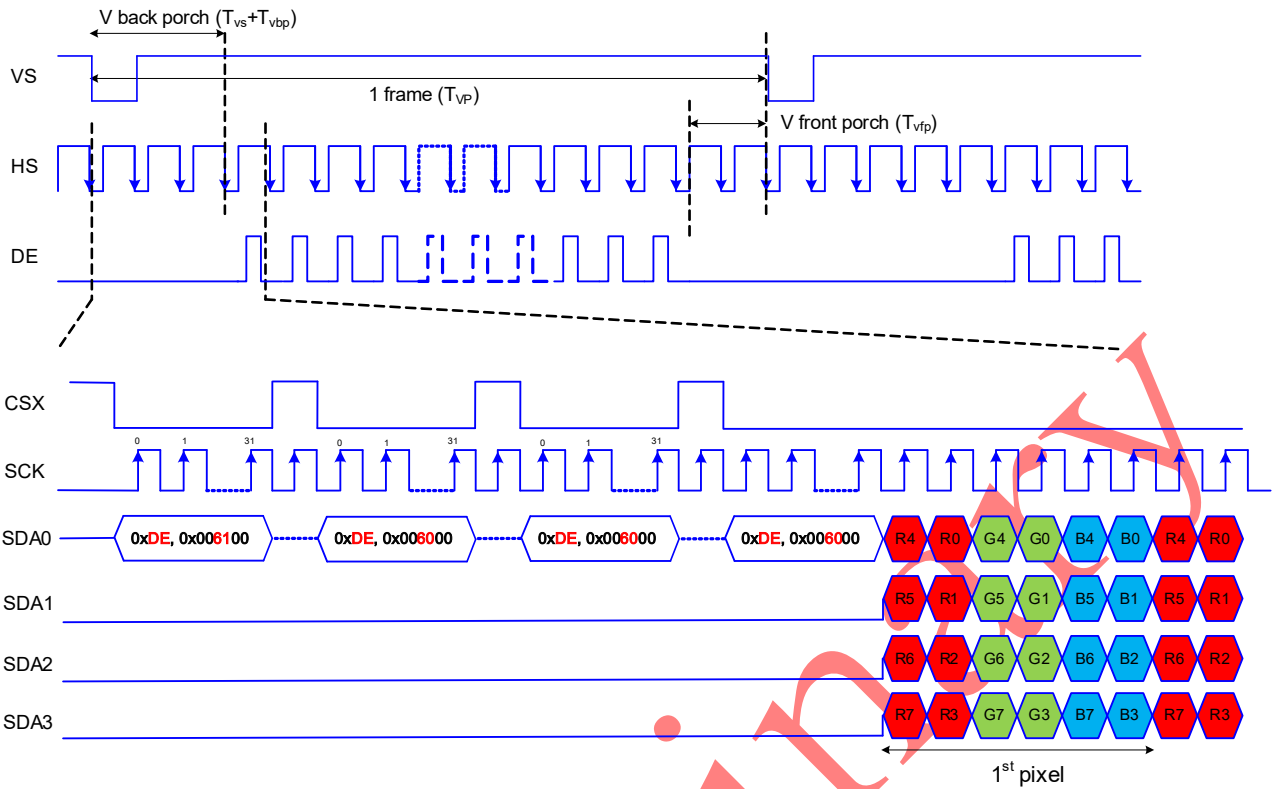

Read command mode

When host reads commands or parameter to ST77903, host needs to send 1 byte of write command instruction (0xDD). Then host sends 3 bytes of AD[23:0] which is composed of 1 byte of 0x00, 1 byte of command address and 1 byte of 0x00. After host sending read command and AD[23:0], the following output data is command address parameter (are parameters). When the last bit of parameter has been output, CSX pin should be returned "H" level.

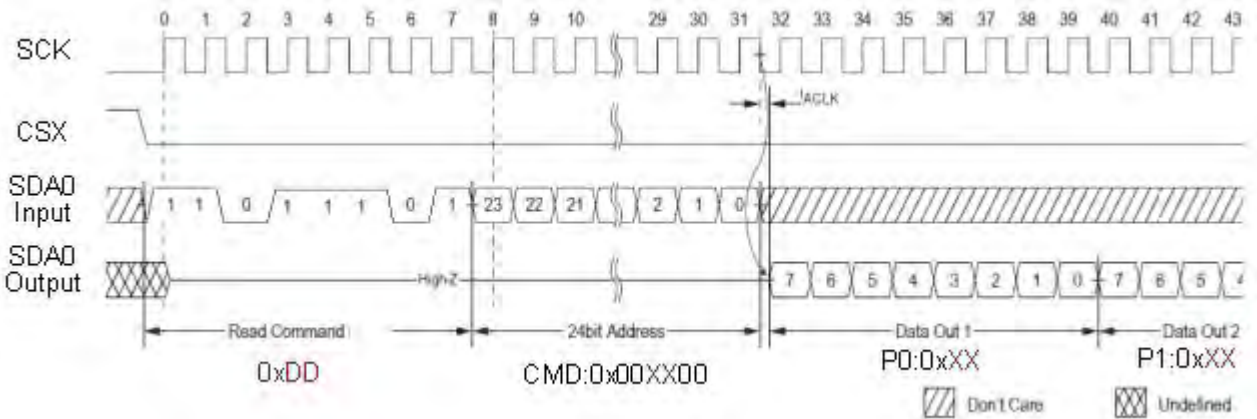

7.6. Color Format

QSPI RGB888

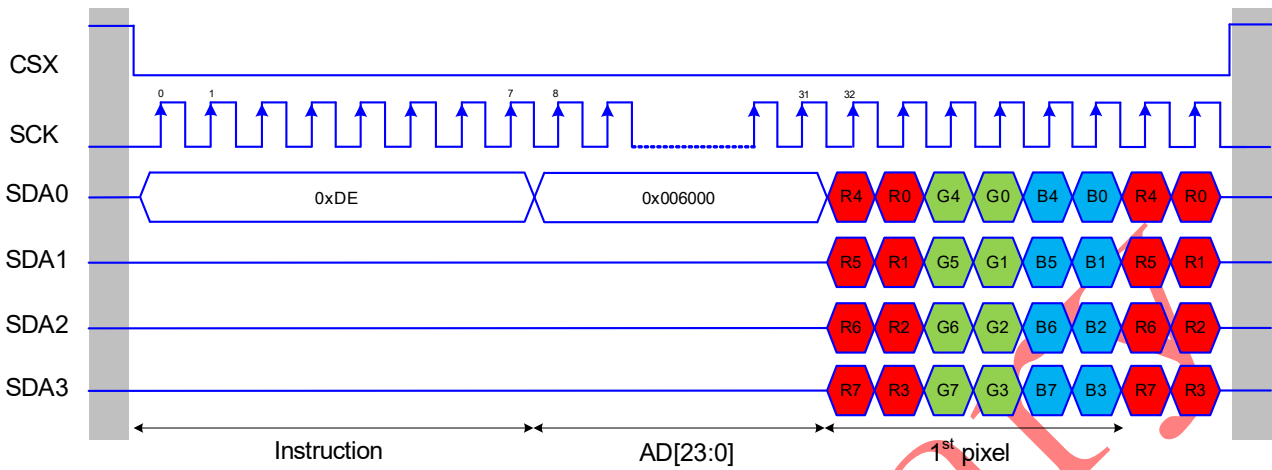

QSPI RGB666

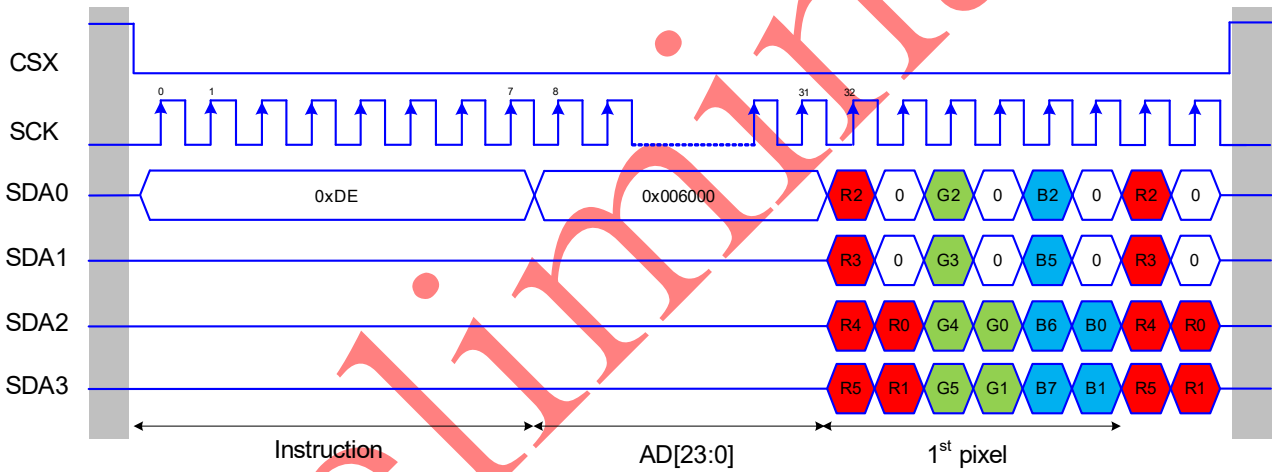

QSPI RGB565

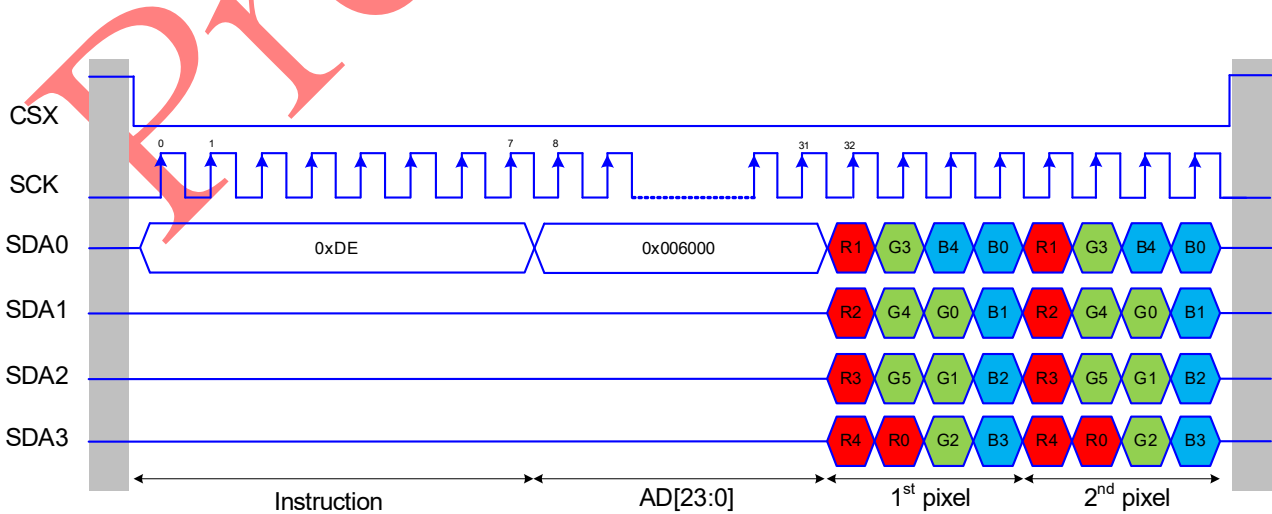

7.7. RGB Interface

RGB Interface Selection

The color format selection of RGB Interface for ST77903 is selected by setting the IM and command 3Ah, DB [7:0].

IM	3Ah	RGB Interface Mode	Data pins
1,0	101	3-SPI with RGB565	DB[7:2]
1,0	110	3-SPI with RGB666	DB[7:2]
1,0	111	3-SPI with RGB888	DB[7:0]
1,1	101	4-SPI with RGB565	DB[7:2]
1,1	110	4-SPI with RGB666	DB[7:2]
1,1	111	4-SPI with RGB888	DB[7:0]

RGB Color Format

ST77903 supports two kinds of RGB interface, DE mode and HV mode, and only 6bit data format. When DE mode is selected and the VSYNC, HSYNC, DOTCLK, DE, D [7:0] pins can be used; when HV mode is selected and the VSYNC, HSYNC, DOTCLK, D [7:0] pins can be used. When using RGB interface, only serial interface can be selected.

serial RGB 565					
Pin	1 st Data	2 nd Data	3 rd Data	...	(3N+1) th Data
DAP[0]	x	x	x	...	x
DAP[1]	x	x	x	...	x
DAP[2]	x	1'G0	x	...	x
DAP[3]	1'R0	1'G1	1'B0	...	N'R0
DAP[4]	1'R1	1'G2	1'B1	...	N'R1
DAP[5]	1'R2	1'G3	1'B2	...	N'R2
DAP[6]	1'R3	1'G4	1'B3	...	N'R3
DAP[7]	1'R4	1'G5	1'B4	...	N'R4

serial RGB 666					
Pin	1 st Data	2 nd Data	3 rd Data	...	(3N+1) th Data
DAP[0]	x	x	x	...	x
DAP[1]	x	x	x	...	x
DAP[2]	1'R0	1'G0	1'B0	...	N'R0
DAP[3]	1'R1	1'G1	1'B1	...	N'R1
DAP[4]	1'R2	1'G2	1'B2	...	N'R2
DAP[5]	1'R3	1'G3	1'B3	...	N'R3
DAP[6]	1'R4	1'G4	1'B4	...	N'R4
DAP[7]	1'R5	1'G5	1'B5	...	N'R5

serial RGB 888					
Pin	1 st Data	2 nd Data	3 rd Data	...	(3N+1) th Data
DAP[0]	1'R0	1'G0	1'B0	...	N'R0
DAP[1]	1'R1	1'G1	1'B1	...	N'R1
DAP[2]	1'R2	1'G2	1'B2	...	N'R2
DAP[3]	1'R3	1'G3	1'B3	...	N'R3
DAP[4]	1'R4	1'G4	1'B4	...	N'R4
DAP[5]	1'R5	1'G5	1'B5	...	N'R5
DAP[6]	1'R6	1'G6	1'B6	...	N'R6
DAP[7]	1'R7	1'G7	1'B7	...	N'R7

Figure 2 RGB Interface Data Format

Preliminary

RGB Interface Definition

The display operation via the RGB interface is synchronized with the VSYNC, HSYNC, and DOTCLK signals. The data can be written only within the specified area with low power consumption by using window address function. The back porch and front porch are used to set the RGB interface timing.

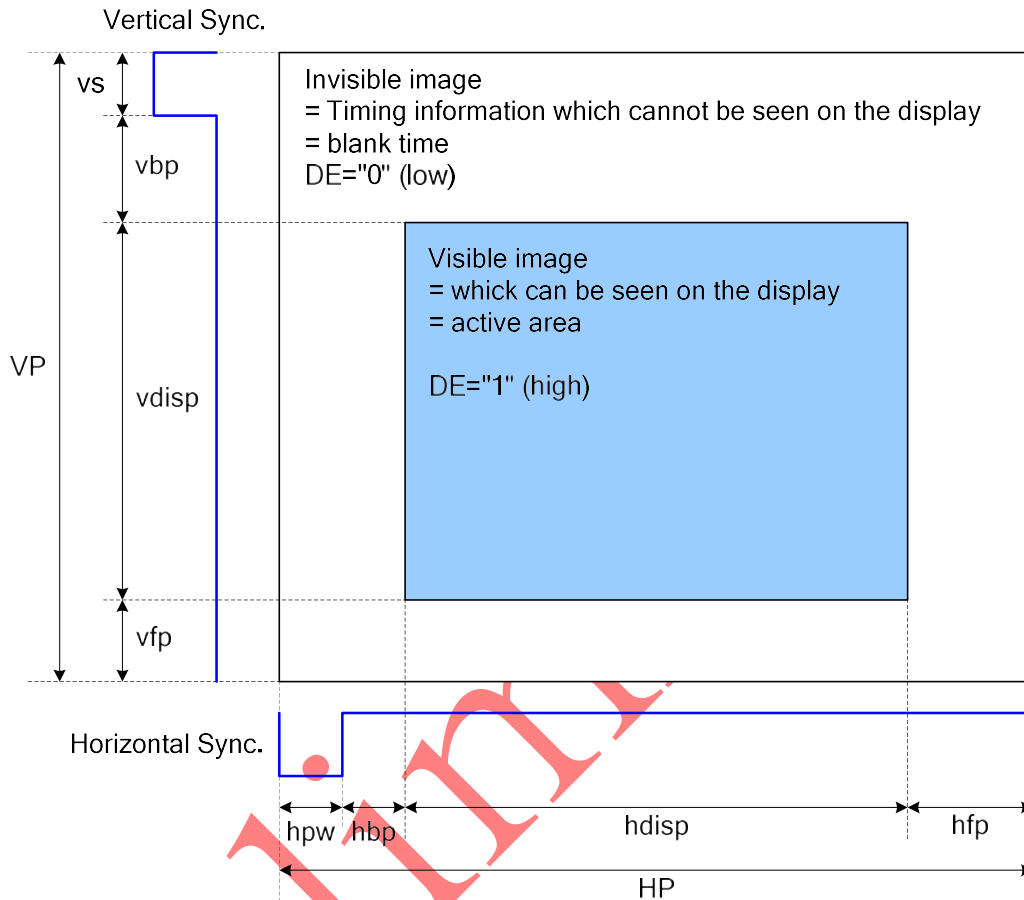

Figure 3 DRAM Access Area by RGB Interface

Please refer to the following table for the setting limitation of RGB interface signals.

6bit RGB interface:

Parameter	Symbol	Min.	Typ.	Max.	Unit
Horizontal Sync. Width	hbw	TBD	TBD	TBD	Clock
Horizontal Sync. Back Porch	hbp	TBD	TBD		Clock
Horizontal Sync. Front Porch	hfp	TBD	TBD	TBD	Clock
Vertical Sync. Width	vs	TBD	TBD	TBD	Line
Vertical Sync. Back Porch	vbp	TBD	TBD		Line
Vertical Sync. Front Porch	vfp	TBD	TBD	TBD	Line

Note:

Typical value are related to the setting of dot clock is 17MHz and frame rate is 60Hz..

In with ram mode, $hbw+hbp+hfp \geq 66$

In without ram mode, $hbw+hbp \geq 60$

RGB Interface Timing

The timing chart of RGB interface DE mode is shown as follows.

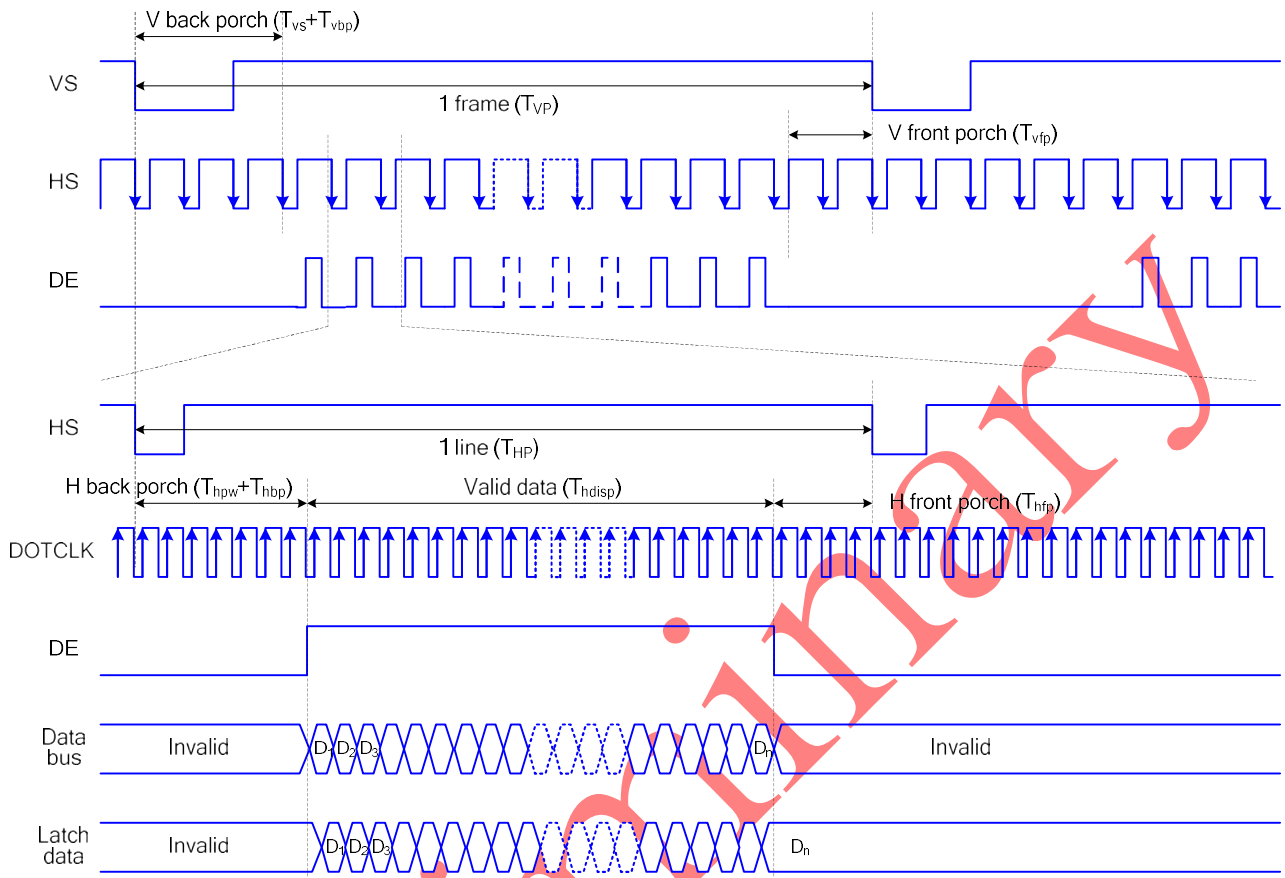

Note: The setting of front porch and back porch in host must match that in IC as this mode.

Figure 4 Timing Chart of Signals in RGB Interface DE Mode

The timing chart of RGB interface HV mode is shown as follows.

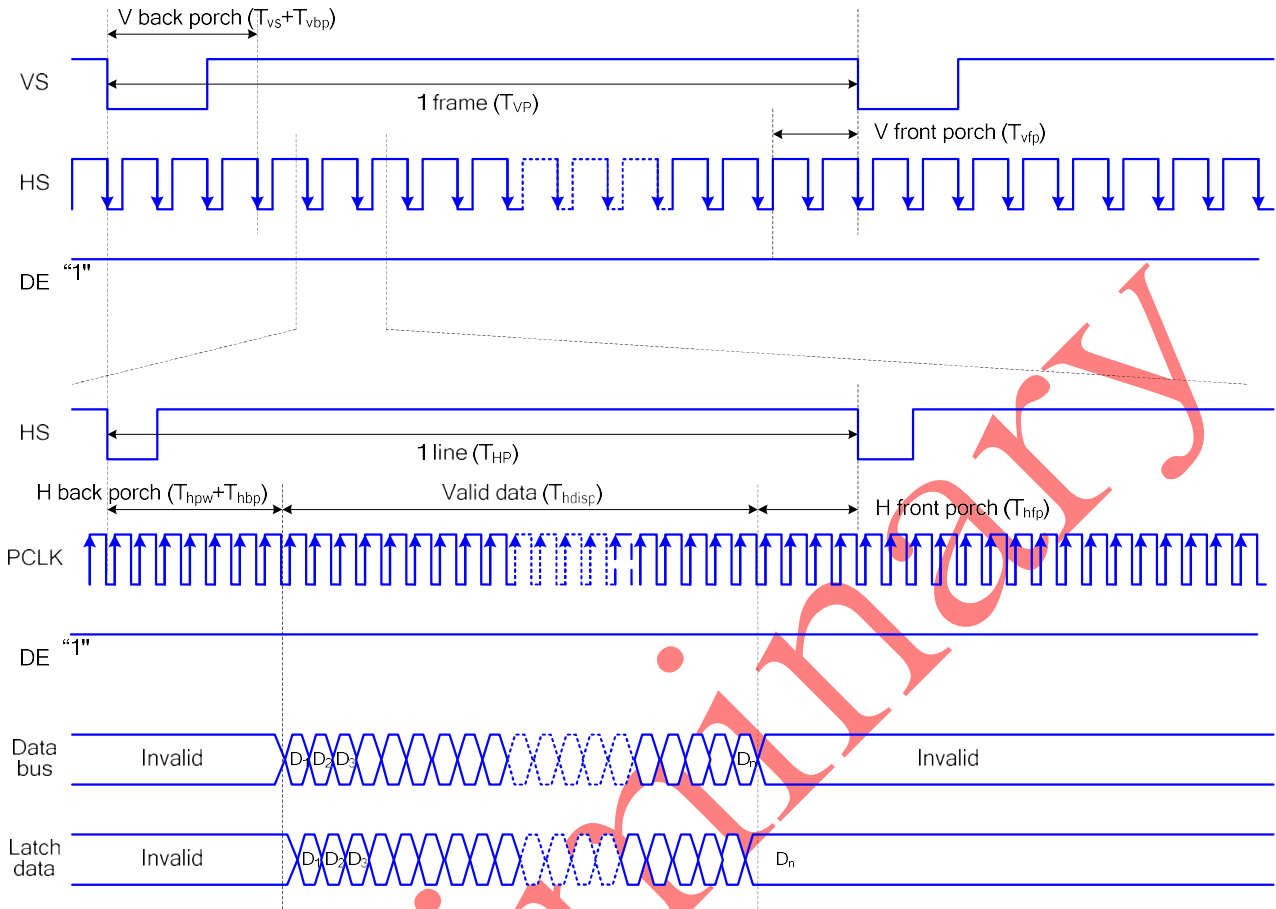

Figure 5 Timing chart of RGB interface HV mod

VSYNC, HSYNC, and DOTCLK signals must be supplied during a display operation period.

In RGB interface mode, the panel controlling signals are generated from DOTCLK, not the internal clock generated from the internal oscillator.

In RGB interface mode, each of RGB dots are transferred in synchronization with DOTCLK signals. In other words, one pixel data needs to take three DOTCLKs to transfer.

In RGB interface mode, the cycles of VSYNC, HSYNC, ENABLE, DOTCLK signals must be set correctly so that the data transfer is completed in units of pixels.

When switching between the internal operation mode and the external display interface operation mode, follow the sequences below in setting instruction.

In RGB interface mode, the front porch period continues until the next VSYNC input is detected after drawing one frame.

In RGB interface mode, a RAM address is set in the address counter every frame on the falling edge of VSYNC.

7.8. Reset Timing

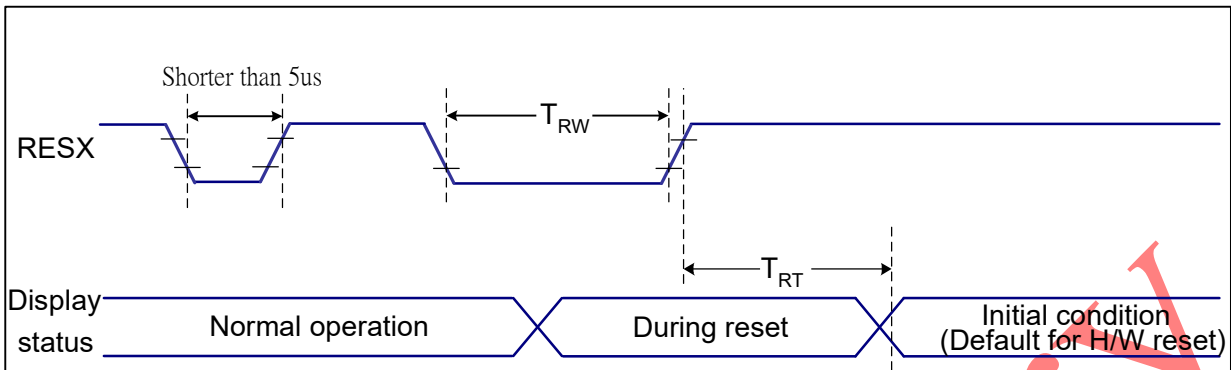

VDDI=1.8V, VCI=2.8V, AGND=DGND=AGNDR=0V, $T_a=25^\circ\text{C}$

Related Pins	Symbol	Parameter	MIN	MAX	Unit
RESX	TRW	Reset pulse duration	10	-	us
	TRT	Reset cancel	-	5 (Note 1, 5)	ms
			-	120 (Note 1, 6, 7)	ms

Notes:

- The reset cancel includes also required time for loading ID bytes, VCOM setting and other settings from NVM (or similar device) to registers. This loading is done every time when there is HW reset cancel time (t_{RT}) within 5 ms after a rising edge of RESX.
- Spike due to an electrostatic discharge on RESX line does not cause irregular system reset according to the table below:

RESX Pulse	Action
Shorter than 5us	Reset Rejected
Longer than 9us	Reset
Between 5us and 9us	Reset starts

- During the Resetting period, the display will be blanked (The display is entering blanking sequence, which maximum time is 120 ms, when Reset Starts in Sleep Out –mode. The display remains the blank state in Sleep In –mode.) and then return to Default condition for Hardware Reset.
- Spike Rejection also applies during a valid reset pulse as shown below:

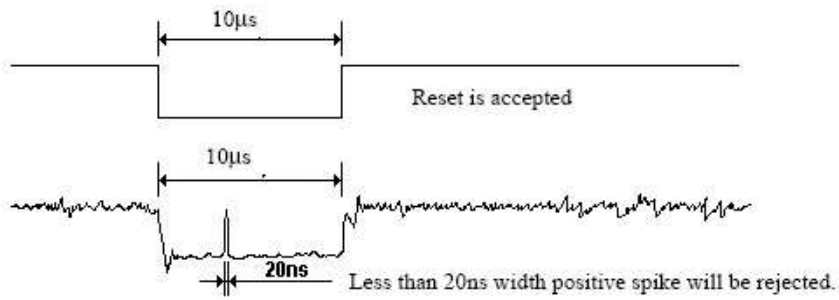

5. When Reset applied during Sleep In Mode.
6. When Reset applied during Sleep Out Mode.
7. It is necessary to wait 5msec after releasing RESX before sending commands. Also Sleep Out command cannot be sent for 120msec.

Preliminary

7.9. Power ON/OFF Sequence

VDDI and VCI can be applied in any order.

VCI and VDDI can be power down in any order.

During power off, if LCD is in the Sleep Out mode, VCI and VDDI must be powered down minimum 120msec after RESX has been released.

During power off, if LCD is in the Sleep In mode, VDDI or VCI can be powered down minimum 0msec after RESX has been released.

Note 1: There will be no damage to the display module if the power sequences are not met.

Note 2: There will be no abnormal visible effects on the display panel during the Power On/Off Sequences.

Note 3: There will be no abnormal visible effects on the display between end of Power On Sequence and before receiving Sleep Out command. Also between receiving Sleep In command and Power Off Sequence.

Note 4: If RESX line is not held stable by host during Power On Sequence as defined in the sequence below, then it will be necessary to apply a Hardware Reset (RESX) after Host Power On Sequence is complete to ensure correct operation. Otherwise function is not guaranteed.

The power on/off sequence is illustrated below

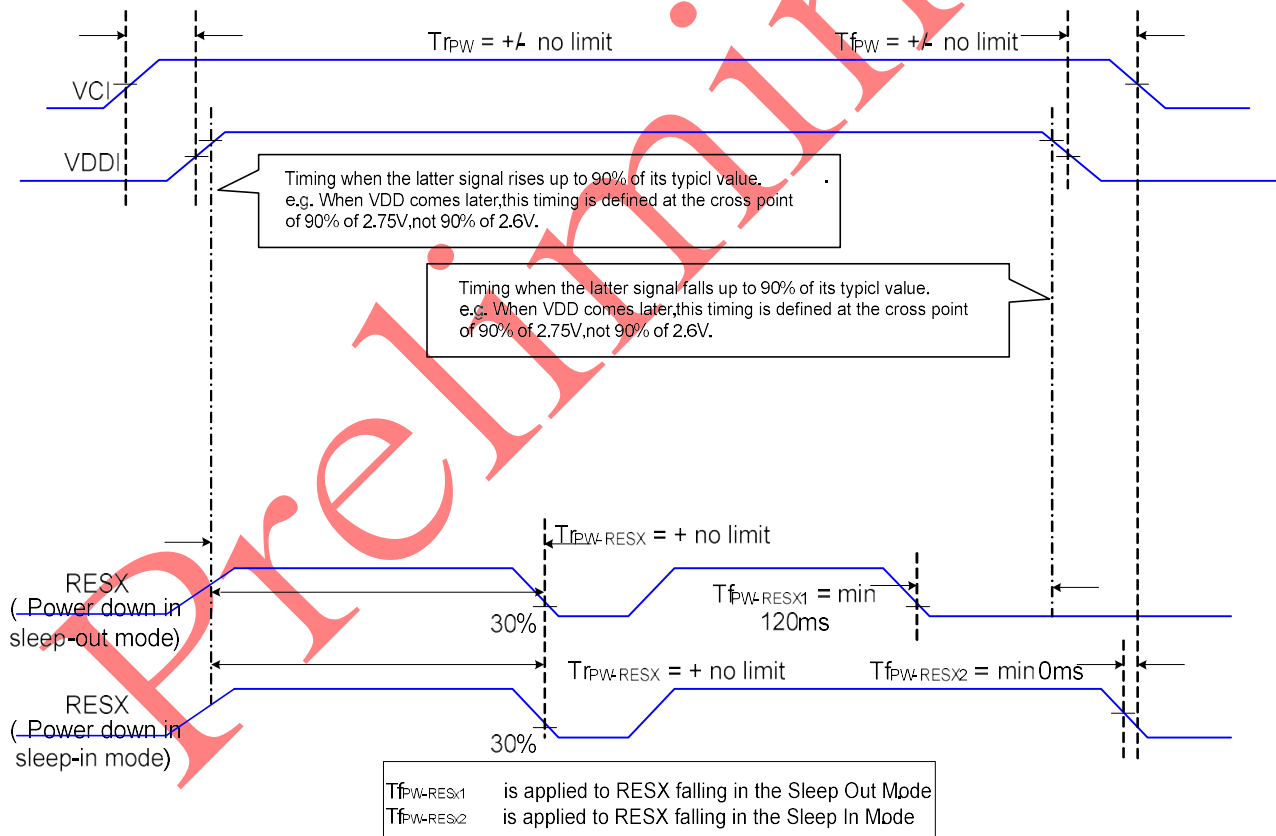

7.10. Uncontrolled Power OFF

The uncontrolled power-off means a situation which removed a battery without the controlled power off sequence. It will neither damage the module or the host interface.

If uncontrolled power-off happened, the display will go blank and there will not any visible effect on the display (blank display) and remains blank until "Power On Sequence" powers it up.

7.11. Power Flow Chart

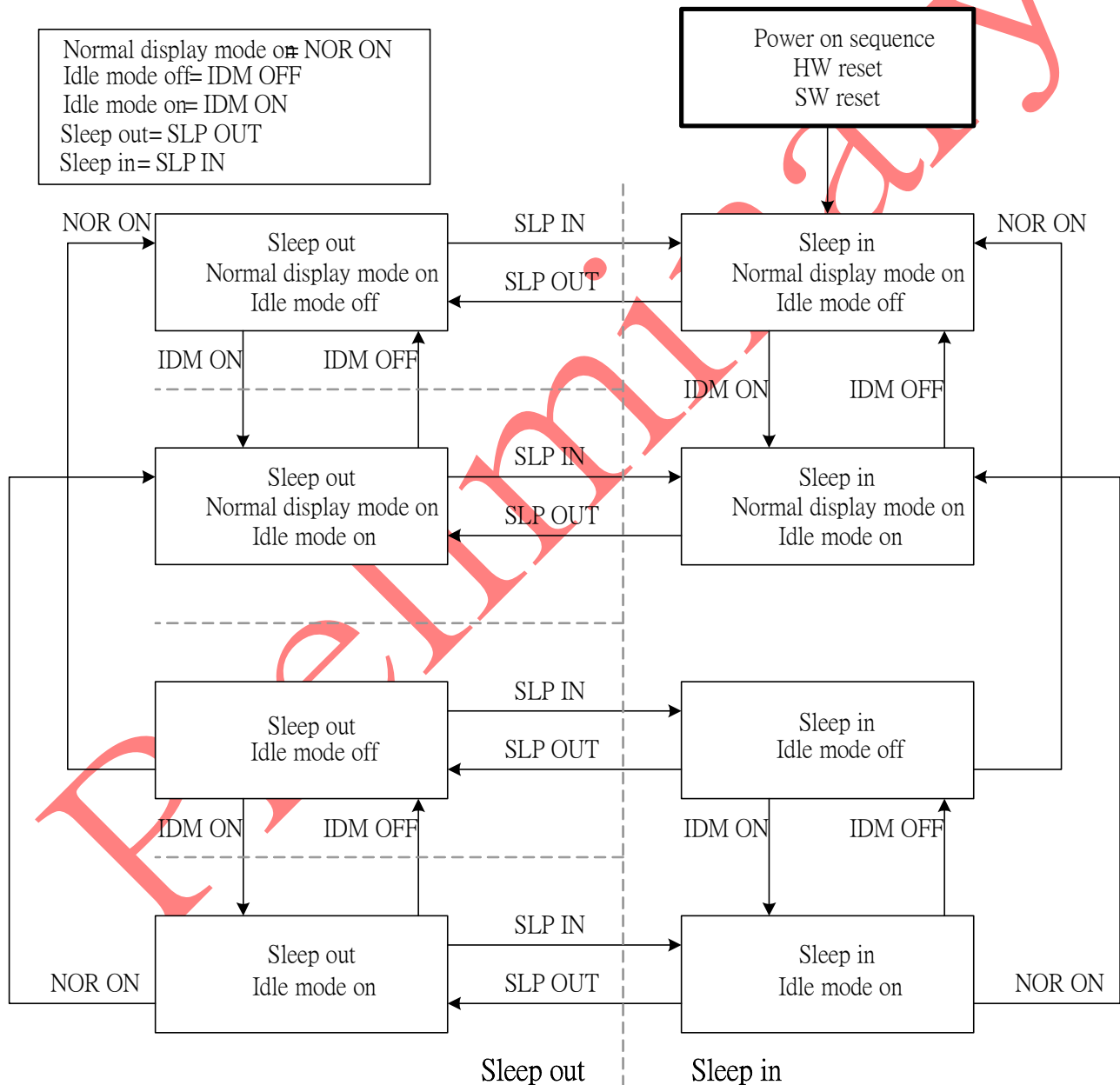

7.12. Voltage Generation

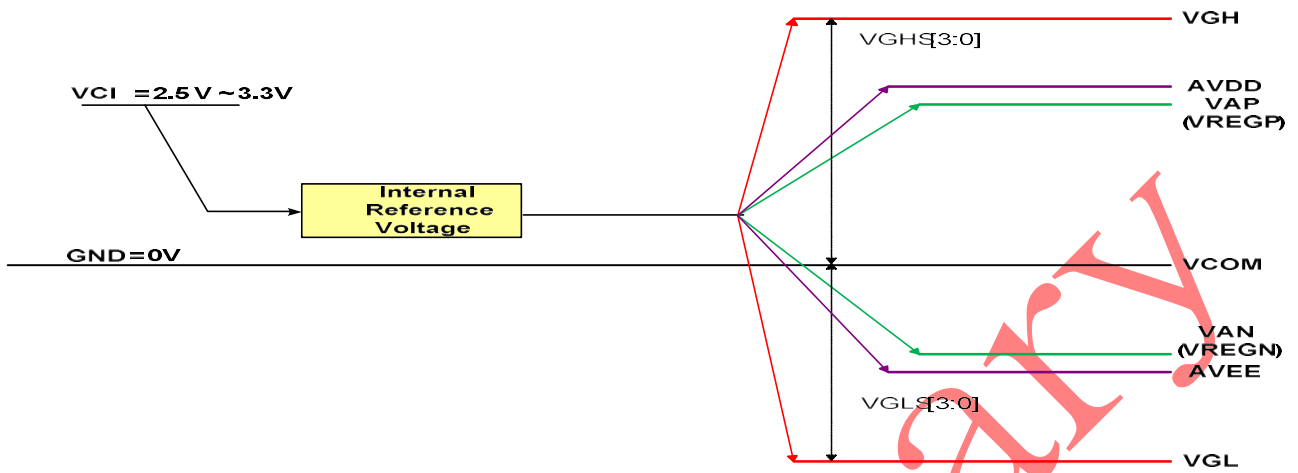

7.13. Relationship about source voltage

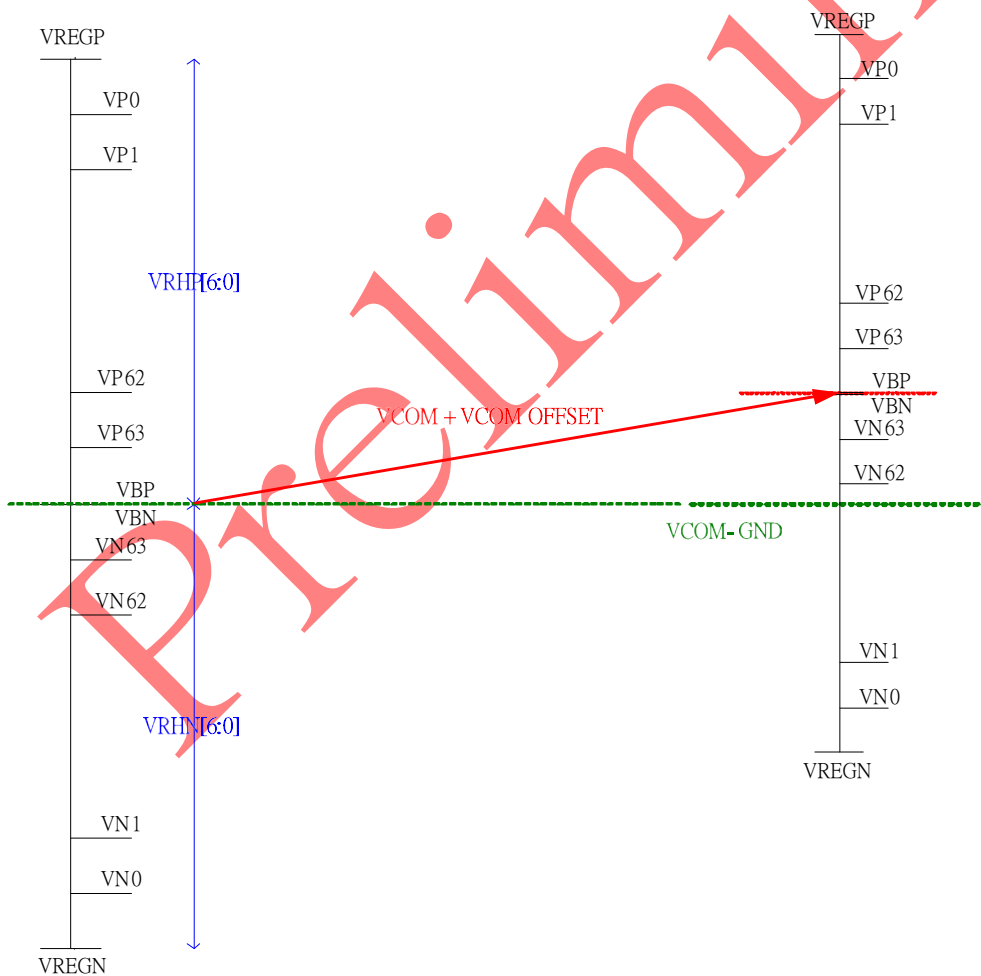

8. FUNCTION DESCRIPTION

8.1. Tearing Effect

The Tearing Effect output line supplies to the MPU a Panel synchronization signal. This signal can be enabled or disabled by the Tearing Effect Line Off & On commands. The mode of the Tearing Effect signal is defined by the parameter of the Tearing Effect Line On command. The signal can be used by the MPU to synchronize Frame Memory Writing when displaying video images.

10.1.1 Tearing effect line modes

Mode 1, the Tearing Effect Output signal consists of V-Blanking Information only:

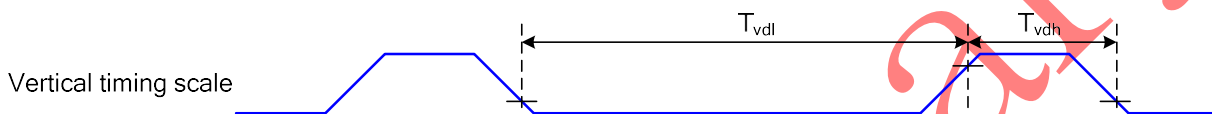

tvdh= The LCD display is not updated from the Frame Memory

tvdl= The LCD display is updated from the Frame Memory (except Invisible Line – see above)

Mode 2, the Tearing Effect Output signal consists of V-Blanking and H-Blanking Information, there is one V-sync and 480 H-sync pulses per field.

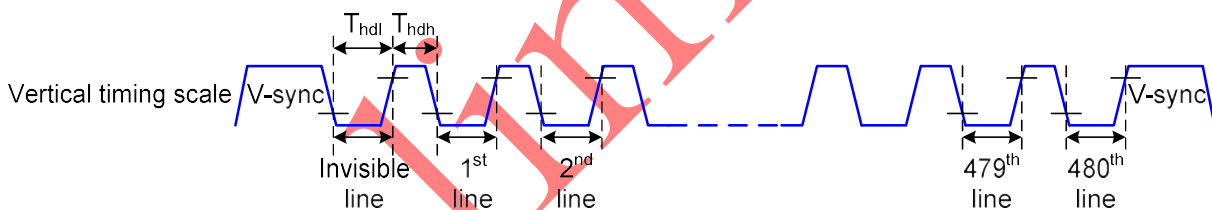

thdh= The LCD display is not updated from the Frame Memory

thdl= The LCD display is updated from the Frame Memory (except Invisible Line – see above)

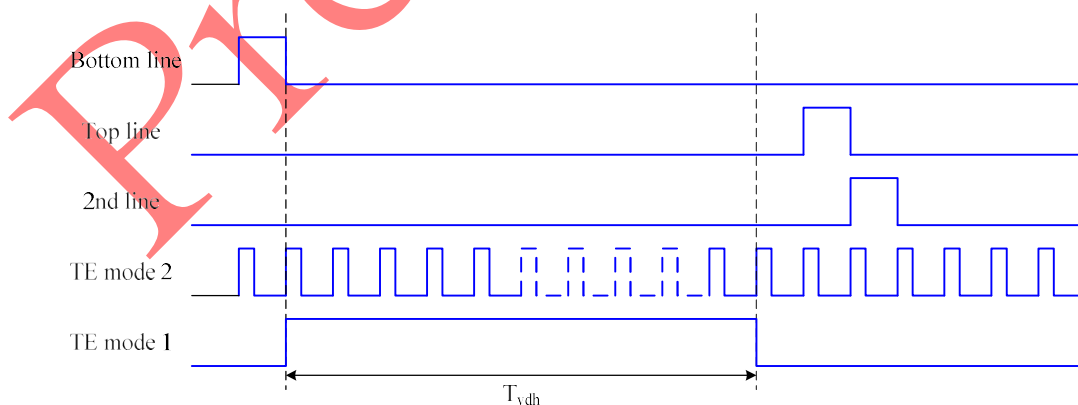

Note: During Sleep In Mode, the Tearing Output Pin is active Low.

8.2. Gamma Correction

ST77903 incorporate the gamma correction function to display 16.7M colors for the LCD panel. The gamma correction is performed with 3 groups of registers, which are gradient adjustment, contrast adjustment and fine- adjustment registers for positive and negative polarities.

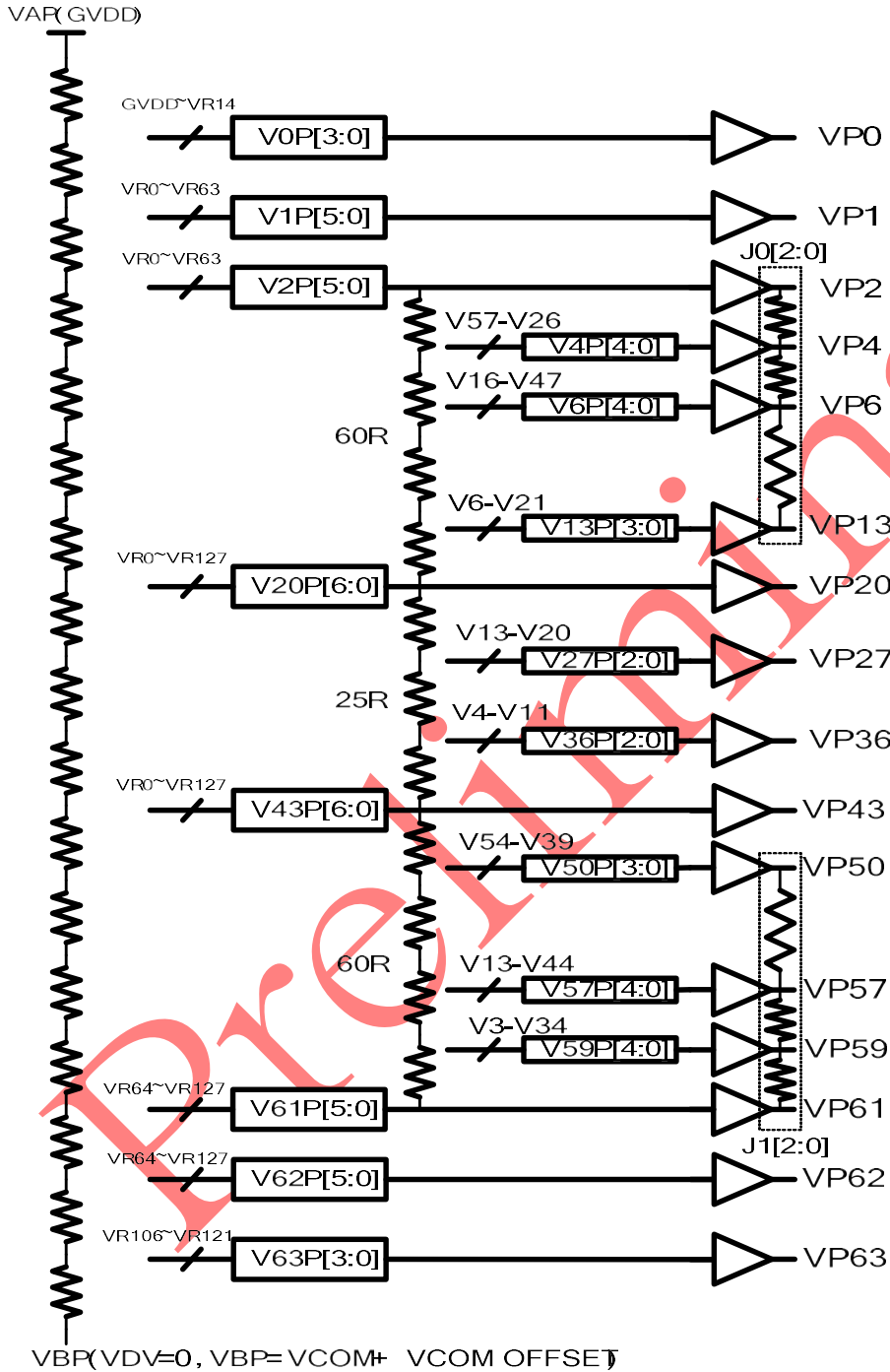

Gray scale Voltage Generation (Positive)

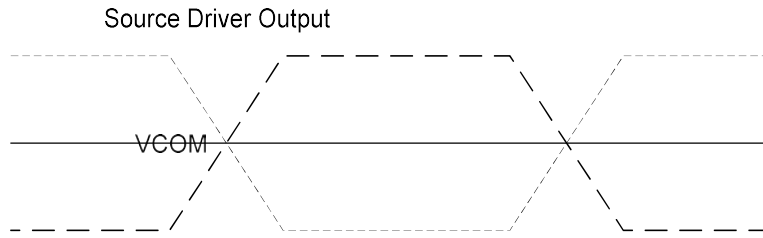

Relationship between Source Output and VCOM

Percentage adjustment:

VJ0P[2:0], VJ1P[2:0], VJ0N[2:0], VJ1N[2:0] these register are used to adjust the voltage level of interpolation point. The following table is the detail description.

VJ0P[2:0]/VJ0N[2:0]:

	00h	01h	02h	03h	04h	05h	06h	07h
VP3/VN3	50%,18	56%,20	50%,18	60%,22	42%,15	65%,23	45%,16	70%,25
VP5/VN5	50%,18	44%,16	50%,18	42%,15	65%,23	52%,19	40%,14	33%,12
VP7/VN7	86%,30	71%,25	80%,28	66%,23	88%,31	70%,25	76%,27	60%,21
VP8/VN8	71%,25	57%,20	63%,22	49%,17	61%,21	52%,18	58%,20	46%,16
VP9/VN9	57%,20	40%,14	49%,17	34%,12	60%,21	41%,15	47%,16	30%,11
VP10/VN10	43%,15	29%,10	34%,12	23%,8	46%,16	25%,9	36%,13	20%,7
VP11/VN11	29%,10	17%,6	20%,7	14%,5	32%,11	26%,9	23%,8	12%,4
VP12/VN12	14%,5	6%,2	9%,3	6%,2	20%,7	11%,4	17%,6	3%,1

VJ1P[2:0]/VJ1N[2:0]:

	00h	01h	02h	03h	04h	05h	06h	07h
VP51/VN51	86%,30	86%,30	86%,30	89%,31	77%,27	92%,32	83%,29	95%,33
VP52/VN52	71%,25	71%,25	77%,27	80%,28	63%,22	69%,24	75%,26	83%,29
VP53/VN53	57%,20	60%,21	63%,22	69%,24	48%,17	54%,19	66%,23	72%,25
VP54/VN54	43%,15	46%,16	46%,16	51%,18	35%,12	41%,14	55%,19	60%,21
VP55/VN55	29%,10	34%,12	31%,11	37%,13	23%,8	40%,14	26%,9	43%,15
VP56/VN56	14%,5	17%,6	14%,5	20%,7	9%,3	23%,8	11%,4	26%,9
VP58/VN58	50%,18	56%,20	47%,17	47%,17	53%,19	59%,21	45%,16	42%,15
VP60/VN60	50%,18	50%,18	50%,18	53%,19	42%,15	45%,16	55%,20	60%,21

voltage level percentage adjustment description

Source voltage of positive gamma level

Gamma level	Related Register	Formula
VP0	V0P[3:0]	$(VAP-VBP) \cdot (129R-V0P[3:0]R) / 129R + VBP$
VP1	V1P[5:0]	$(VAP-VBP) \cdot (128R-V1P[5:0]R) / 129R + VBP$
VP2	V2P[5:0]	$(VAP-VBP) \cdot (128R-V2P[5:0]R) / 129R + VBP$
VP3	VJ0P[2:0]	$(VP2-VP4) \cdot VJ0P[2:0] + VP4$
VP4	V4P[4:0]	$(VP2-VP20) \cdot (57R-V4P[4:0]) / 60R + VP20$
VP5	VJ0P[2:0]	$(VP4-VP6) \cdot VJ0P[2:0] + VP6$
VP6	V6P[4:0]	$(VP2-VP20) \cdot (47R-V6P[4:0]) / 60R + VP20$
VP7	VJ0P[2:0]	$(VP6-VP13) \cdot VJ0P[2:0] + VP13$
VP8	VJ0P[2:0]	$(VP6-VP13) \cdot VJ0P[2:0] + VP13$
VP9	VJ0P[2:0]	$(VP6-VP13) \cdot VJ0P[2:0] + VP13$
VP10	VJ0P[2:0]	$(VP6-VP13) \cdot VJ0P[2:0] + VP13$
VP11	VJ0P[2:0]	$(VP6-VP13) \cdot VJ0P[2:0] + VP13$
VP12	VJ0P[2:0]	$(VP6-VP13) \cdot VJ0P[2:0] + VP13$
VP13	V13P[3:0]	$(VP2-VP20) \cdot (21R-V13P[3:0]) / 60R + VP20$
VP14	--	$(VP13-VP20) / (20-13) \cdot (20-14) + VP20$
VP15	--	$(VP13-VP20) / (20-13) \cdot (20-15) + VP20$
VP16	--	$(VP13-VP20) / (20-13) \cdot (20-16) + VP20$
VP17	--	$(VP13-VP20) / (20-13) \cdot (20-17) + VP20$
VP18	--	$(VP13-VP20) / (20-13) \cdot (20-18) + VP20$
VP19	--	$(VP13-VP20) / (20-13) \cdot (20-19) + VP20$
VP20	V20P[6:0]	$(VAP-VBP) \cdot (128R-V20P[6:0]R) / 129R + VBP$
VP21	--	$(VP20-VP27) / (27-20) \cdot (27-21) + VP27$
VP22	--	$(VP20-VP27) / (27-20) \cdot (27-22) + VP27$
VP23	--	$(VP20-VP27) / (27-20) \cdot (27-23) + VP27$
VP24	--	$(VP20-VP27) / (27-20) \cdot (27-24) + VP27$
VP25	--	$(VP20-VP27) / (27-20) \cdot (27-25) + VP27$
VP26	--	$(VP20-VP27) / (27-20) \cdot (27-26) + VP27$
VP27	V27P[2:0]	$(VP20-VP43) \cdot (20R-V27P[2:0]) / 25R + VP43$
VP28	--	$(VP27-VP36) / (36-27) \cdot (36-28) + VP36$
VP29	--	$(VP27-VP36) / (36-27) \cdot (36-29) + VP36$
VP30	--	$(VP27-VP36) / (36-27) \cdot (36-30) + VP36$
VP31	--	$(VP27-VP36) / (36-27) \cdot (36-31) + VP36$
VP32	--	$(VP27-VP36) / (36-27) \cdot (36-32) + VP36$
VP33	--	$(VP27-VP36) / (36-27) \cdot (36-33) + VP36$
VP34	--	$(VP27-VP36) / (36-27) \cdot (36-34) + VP36$
VP35	--	$(VP27-VP36) / (36-27) \cdot (36-35) + VP36$
VP36	V36P[2:0]	$(VP20-VP43) \cdot (11R-V36P[2:0]) / 25R + VP43$
VP37	--	$(VP36-VP43) / (43-36) \cdot (43-37) + VP43$
VP38	--	$(VP36-VP43) / (43-36) \cdot (43-38) + VP43$
VP39	--	$(VP36-VP43) / (43-36) \cdot (43-39) + VP43$
VP40	--	$(VP36-VP43) / (43-36) \cdot (43-40) + VP43$
VP41	--	$(VP36-VP43) / (43-36) \cdot (43-41) + VP43$
VP42	--	$(VP36-VP43) / (43-36) \cdot (43-42) + VP43$
VP43	V43P[6:0]	$(VAP-VBP) \cdot (128R-V43P[6:0]R) / 129R + VBP$
VP44	--	$(VP43-VP50) / (50-43) \cdot (50-44) + VP50$
VP45	--	$(VP43-VP50) / (50-43) \cdot (50-45) + VP50$
VP46	--	$(VP43-VP50) / (50-43) \cdot (50-46) + VP50$
VP47	--	$(VP43-VP50) / (50-43) \cdot (50-47) + VP50$
VP48	--	$(VP43-VP50) / (50-43) \cdot (50-48) + VP50$
VP49	--	$(VP43-VP50) / (50-43) \cdot (50-49) + VP50$
VP50	V50P[3:0]	$(VP43-VP61) \cdot (54R-V50P[3:0]) / 60R + VP61$
VP51	VJ1P[2:0]	$(V5P0-VP57) \cdot VJ1P[2:0] + VP57$
VP52	VJ1P[2:0]	$(VP50-VP57) \cdot VJ1P[2:0] + VP57$

VP53	VJ1P[2:0]	$(VP50-VP57)*VJ1P[2:0]+VP57$
VP54	VJ1P[2:0]	$(VP50-VP57)*VJ1P[2:0]+VP57$
VP55	VJ1P[2:0]	$(VP50-VP57)*VJ1P[2:0]+VP57$
VP56	VJ1P[2:0]	$(VP50-VP57)*VJ1P[2:0]+VP57$
VP57	V57P[4:0]	$(VP43-VP61)*(44R-V57P[4:0])/60R+VP61$
VP58	VJ1P[2:0]	$(VP57-VP59)*VJ1P[2:0]+VP59$
VP59	V59P[4:0]	$(VP43-VP61)*(34R-V59P[4:0])/60R+VP61$
VP60	VJ1P[2:0]	$(VP59-VP61)*VJ1P[2:0]+VP61$
VP61	V61P[5:0]	$(VAP-VBP)*(64R-V61P[5:0]R)/129R+VBP$
VP62	V62P[5:0]	$(VAP-VBP)*(64R-V62P[5:0]R)/129R+VBP$
VP63	V63P[3:0]	$(VAP-VBP)*(23R-V63P[3:0]R)/129R+VBP$

Source voltage of negative gamma level

Gamma level	Related Register	Formula
VN0	V0N[3:0]	$VBN-(VBN-VAN)*(129R-V0N[3:0]R)/129R$
VN1	V1N[5:0]	$VBN-(VBN-VAN)*(128R-V1N[5:0]R)/129R$
VN2	V2N[5:0]	$VBN-(VBN-VAN)*(128R-V2N[5:0]R)/129R$
VN3	VJ0N[2:0]	$(VN2-VN4)*VJ0N[2:0]+VN4$
VN4	V4N[4:0]	$(VN2-VN20)*(57R-V4N[4:0])/60R+VN20$
VN5	VJ0N[2:0]	$(VN4-VN6)*VJ0N[2:0]+VN6$
VN6	V6N[4:0]	$(VN2-VN20)*(47R-V6N[4:0])/60R+VN20$
VN7	VJ0N[2:0]	$(VN6-VN13)*VJ0N[2:0]+VN13$
VN8	VJ0N[2:0]	$(VN6-VN13)*VJ0N[2:0]+VN13$
VN9	VJ0N[2:0]	$(VN6-VN13)*VJ0N[2:0]+VN13$
VN10	VJ0N[2:0]	$(VN6-VN13)*VJ0N[2:0]+VN13$
VN11	VJ0N[2:0]	$(VN6-VN13)*VJ0N[2:0]+VN13$
VN12	VJ0N[2:0]	$(VN6-VN13)*VJ0N[2:0]+VN13$
VN13	V13N[3:0]	$(VN2-VN20)*(21R-V13N[3:0])/60R+VN20$
VN14	--	$(VN13-VN20)/(20-13)*(20-14)+VN20$
VN15	--	$(VN13-VN20)/(20-13)*(20-15)+VN20$
VN16	--	$(VN13-VN20)/(20-13)*(20-16)+VN20$
VN17	--	$(VN13-VN20)/(20-13)*(20-17)+VN20$
VN18	--	$(VN13-VN20)/(20-13)*(20-18)+VN20$
VN19	--	$(VN13-VN20)/(20-13)*(20-19)+VN20$
VN20	V20N[6:0]	$VBN-(VBN-VAN)*(128R-V20N[6:0]R)/129R$
VN21	--	$(VN20-VN27)/(27-20)*(27-21)+VN27$
VN22	--	$(VN20-VN27)/(27-20)*(27-22)+VN27$
VN23	--	$(VN20-VN27)/(27-20)*(27-23)+VN27$
VN24	--	$(VN20-VN27)/(27-20)*(27-24)+VN27$
VN25	--	$(VN20-VN27)/(27-20)*(27-25)+VN27$
VN26	--	$(VN20-VN27)/(27-20)*(27-26)+VN27$
VN27	V27N[2:0]	$(VN20-VN43)*(20R-V27N[2:0])/25R+VN43$
VN28	--	$(VN27-VN36)/(36-27)*(36-28)+VN36$
VN29	--	$(VN27-VN36)/(36-27)*(36-29)+VN36$
VN30	--	$(VN27-VN36)/(36-27)*(36-30)+VN36$
VN31	--	$(VN27-VN36)/(36-27)*(36-31)+VN36$
VN32	--	$(VN27-VN36)/(36-27)*(36-32)+VN36$
VN33	--	$(VN27-VN36)/(36-27)*(36-33)+VN36$
VN34	--	$(VN27-VN36)/(36-27)*(36-34)+VN36$
VN35	--	$(VN27-VN36)/(36-27)*(36-35)+VN36$
VN36	V36N[2:0]	$(VN20-VN43)*(11R-V36N[2:0])/25R+VN43$
VN37	--	$(VN36-VN43)/(43-36)*(43-37)+VN43$
VN38	--	$(VN36-VN43)/(43-36)*(43-38)+VN43$
VN39	--	$(VN36-VN43)/(43-36)*(43-39)+VN43$

VN40	--	$(VN36-VN43)/(43-36)*(43-40)+VN43$
VN41	--	$(VN36-VN43)/(43-36)*(43-41)+VN43$
VN42	--	$(VN36-VN43)/(43-36)*(43-42)+VN43$
VN43	V43N[6:0]	$VBN-(VBN-VAN)*(128R-V43N[6:0]R)/129R$
VN44	--	$(VN43-VN50)/(50-43)*(50-44)+VN50$
VN45	--	$(VN43-VN50)/(50-43)*(50-45)+VN50$
VN46	--	$(VN43-VN50)/(50-43)*(50-46)+VN50$
VN47	--	$(VN43-VN50)/(50-43)*(50-47)+VN50$
VN48	--	$(VN43-VN50)/(50-43)*(50-48)+VN50$
VN49	--	$(VN43-VN50)/(50-43)*(50-49)+VN50$
VN50	V50N[3:0]	$(VN43-VN61)*(54R-V50N[3:0])/60R+VN61$
VN51	VJ1N[2:0]	$(V5N0-VN57)*VJ1N[2:0]+VN57$
VN52	VJ1N[2:0]	$(VN50-VN57)*VJ1N[2:0]+VN57$
VN53	VJ1N[2:0]	$(VN50-VN57)*VJ1N[2:0]+VN57$
VN54	VJ1N[2:0]	$(VN50-VN57)*VJ1N[2:0]+VN57$
VN55	VJ1N[2:0]	$(VN50-VN57)*VJ1N[2:0]+VN57$
VN56	VJ1N[2:0]	$(VN50-VN57)*VJ1N[2:0]+VN57$
VN57	V57N[4:0]	$(VN43-VN61)*(44R-V57N[4:0])/60R+VN61$
VN58	VJ1N[2:0]	$(VN57-VN59)*VJ1N[2:0]+VN59$
VN59	V59N[4:0]	$(VN43-VN61)*(34R-V59N[4:0])/60R+VN61$
VN60	VJ1N[2:0]	$(VN59-VN61)*VJ1N[2:0]+VN61$
VN61	V61N[5:0]	$VBN-(VBN-VAN)*(64R-V61N[5:0]R)/129R$
VN62	V62N[5:0]	$VBN-(VBN-VAN)*(64R-V62N[5:0]R)/129R$
VN63	V63N[3:0]	$VBN-(VBN-VAN)*(23R-V63N[3:0]R)/129R$

Preliminary

9 NVM PROGRAMMING FLOW

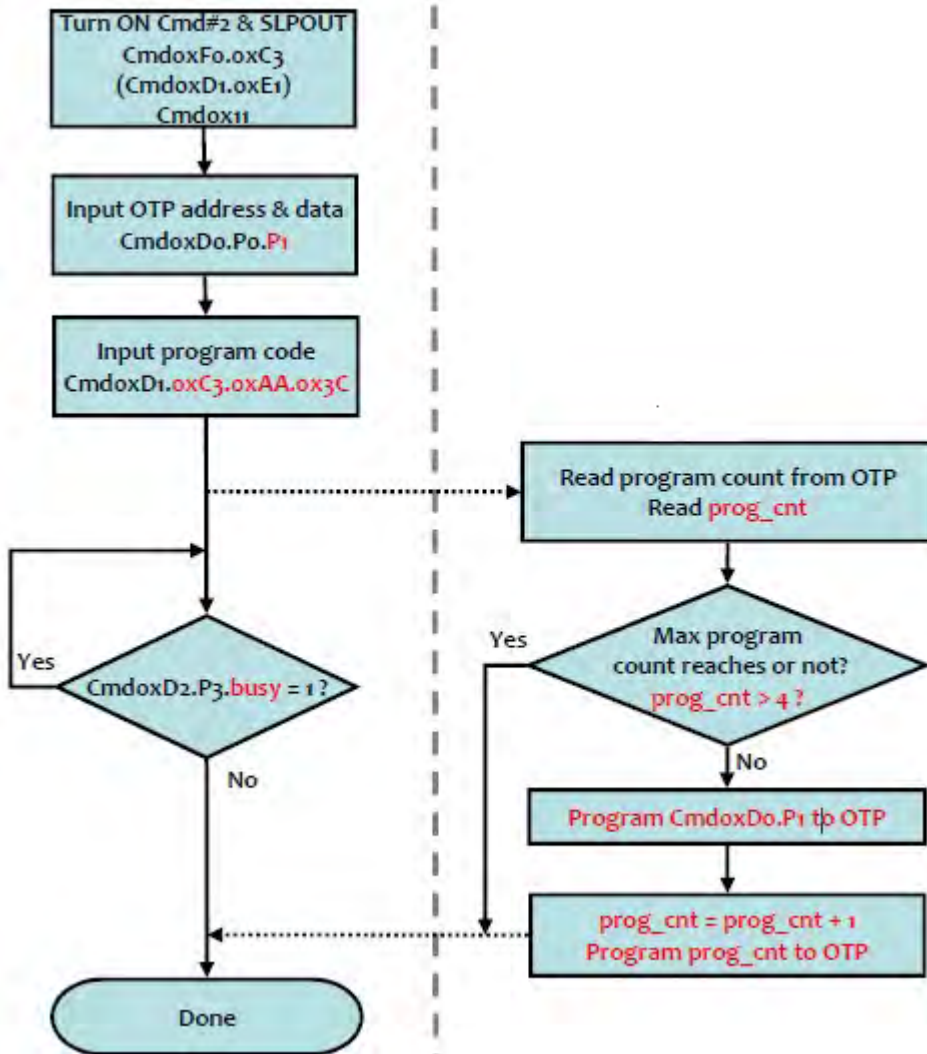

10 APPLICATION NOTE

10.1.. Layout Resistance Suggestion

Pin Name	Type	Maximum Resistance	
VDDI, VDDA, AGND, DGND, AGNDR	Power supply	10	Ω
VPP	Power supply	10	Ω
DA0,DA1,DA2,DA3	Interface	100	Ω
VCC, VCCM, VGH, VGHS, VGL, SVDD, SVEE, AVDD, AVEE, VDDM, VDDR	Power supply	10	Ω
IMP, RESET, CSXP, OSCIP, SCKP,DCXP	I	100	Ω
TE	O	100	Ω

Preliminary

11. COMMAND

11.1. Command Table List

COMMAND Table 1														
Instruction	D/CX	WRX	RDX	PNUM	D7	D6	D5	D4	D3	D2	D1	D0	Hex	Function
NOP	0	↑	1	-	0	0	0	0	0	0	0	0	(00h)	No operation
SWRESET	0	↑	1	-	0	0	0	0	0	0	0	1	(01h)	Software reset
RDDID	0	↑	1	-	0	0	0	0	0	1	0	0	(04h)	Read display ID
	1	1	↑		ID1.7-0								(FFh)	ID1 read
	1	1	↑		ID2.7-0								(FFh)	ID2 read
	1	1	↑		ID3.7-0								(FFh)	ID3 read
Read Number of Errors on DSI	0	↑	1	-	0	0	0	0	0	1	0	1	(05h)	Read DSI
	1	1	↑		P.7-0								(00h)	
RDDST	0	↑	1	-	0	0	0	0	1	0	0	1	(09h)	Read display status
	1	1	↑		BSTON	0	0	0	ML	BGR	MH	0	(00h)	
	1	1	↑		0	DBI.2-0			IDMON	0	SLOUT	0	(60h)	
	1	1	↑		0	0	INVO	0	0	DISON	TEON	0	(00h)	
	1	1	↑		0	0	TEM	0	0	0	0	0	(00h)	
RDDPM	0	↑	1	-	0	0	0	0	1	0	1	0	(0Ah)	Read display power
	1	1	↑		BSTON	IDMON	0	SLPOUT	0	DISON	0	0	(00h)	
RDD MADCTL	0	↑	1	-	0	0	0	0	1	0	1	1	(0Bh)	Read display
	1	1	↑		0	0	0	ML	BGR	MH	0	0	(00h)	
RDD COLMOD	0	↑	1	-	0	0	0	0	1	1	0	0	(0Ch)	Read display pixel format
	1	1	↑		0	0	0	0	0	DBI.2-0			(06h)	
RDDIM	0	↑	1	-	0	0	0	0	1	1	0	1	(0Dh)	Read display image mode
	1	1	↑		-	0	INVO	0	0	0	0	0	(00h)	
RDDSM	0	↑	1	-	0	0	0	0	1	1	1	0	(0Eh)	Read display signal mode
	1	1	↑		TEON	TEM	HSO	VSO	PCLKO	DEON	0	EOD	(00h)	
RDDSDR	0	↑	1	-	0	0	0	0	1	1	1	1	(0Fh)	Read display self-diagnostic result
	1	1	↑		RELD	FUND	0	0	0	0	0	CSCMP	(00h)	
SLPIN	0	↑	1	-	0	0	0	1	0	0	0	0	(10h)	Sleep in
SLPOUT	0	↑	1	-	0	0	0	1	0	0	0	1	(11h)	Sleep out
INVOFF	0	↑	1	-	0	0	1	0	0	0	0	0	(20h)	Display inversion off
INVON	0	↑	1	-	0	0	1	0	0	0	0	1	(21h)	Display inversion on

COMMAND Table 1

Instruction	D/CX	WRX	RDX	PNUM	D7	D6	D5	D4	D3	D2	D1	D0	Hex	Function
DISPOFF	0	↑	1	-	0	0	1	0	1	0	0	0	(28h)	Display off
DISPON	0	↑	1	-	0	0	1	0	1	0	0	1	(29h)	Display on
RAMWR	0	↑	1	-	0	0	1	0	1	1	0	0	(2Ch)	Memory write
	1	↑	1		D1.7-0								-	
	1	↑	1		Dx.7-0								-	
	1	↑	1		Dn.7-0								-	
TEOFF	0	↑	1	-	0	0	1	1	0	1	0	0	(34h)	Tearing effect off
TEON	0	↑	1	1	0	0	1	1	0	1	0	1	(35h)	Tearing effect on
	1	↑	1		-	-	-	-	-	-	-	M	(00h)	
MADCTL	0	↑	1	1	0	0	1	1	0	1	1	0	(36h)	Memory access control
	1	↑	1		-	-	-	ML	BGR	MH	-	-	(00h)	
IDMOFF	0	↑	1	-	0	0	1	1	1	0	0	0	(38h)	Idle mode off
IDMON	0	↑	1	-	0	0	1	1	1	0	0	1	(39h)	Idle mode on
COLMOD	0	↑	1	1	0	0	1	1	1	0	1	0	(3Ah)	Interface pixel format
	1	↑	1		-	-	-	-	-	DBI.2-0			(06h)	
RAMWRC	0	↑	1	-	0	0	1	1	1	1	0	0	(3Ch)	Memory write continue
	1	↑	1		D1.7-0								-	
	1	↑	1		Dx.7-0								-	
	1	↑	1		Dn.7-0								-	
TESLWR	0	↑	1	2	0	1	0	0	0	1	0	0	(44h)	Write tear scan line
	1	↑	1		-	-	-	-	-	-	-	N.8	(00h)	
	1	↑	1		N.7-0								(00h)	
TESLRD	0	↑	1	-	0	1	0	0	0	1	0	1	(45h)	Read scanline
	1	↑	1		-	-	-	-	-	-	-	N.8	(00h)	
	1	↑	1		N.7-0								(00h)	
WRIDMC	0	↑	1	1	1	0	0	1	0	0	0	0	(90h)	Write two-color idle mode
	1	↑	1		-	-	-	-	-	R	G	B	(07h)	
RDIDMC	0	↑	1	-	1	0	0	1	0	0	0	1	(91h)	Read two-color idle mode
	1	↑	1		-	-	-	-	-	R	G	B	(07h)	

COMMAND Table 1														
Instruction	D/CX	WRX	RDX	PNUM	D7	D6	D5	D4	D3	D2	D1	D0	Hex	Function
RDFCHKSUM	0	↑	1	-	1	0	1	0	1	0	1	0	(AAh)	Read First Checksum
	1	1	↑	-	FCS.7-0							-		
RDCCHKSUM	0	↑	1	-	1	0	1	0	1	1	1	1	(Afh)	Read Continue
	1	1	↑	-	CCS.7-0							-	Checksum	
RDID1	0	↑	1	-	1	1	0	1	1	0	1	0	(Dah)	Read ID1
	1	1	↑	-	ID1.7-0							-		
RDID2	0	↑	1	-	1	1	0	1	1	0	1	1	(DBh)	Read ID2
	1	1	↑	-	ID2.7-0							-		
RDID3	0	↑	1	-	1	1	0	1	1	1	0	0	(DCh)	Read ID3
	1	1	↑	-	ID3.7-0							-		
HS	0	↑	1	-	0	1	1	0	0	0	0	0	(60h)	H SYNC Command
VS	0	↑	1	-	0	1	1	0	0	0	0	1	(61h)	V SYNC Command

11.2. Command Table 1

- NOP (00h)

00H	NOP (No Operation)																								
Inst / Para	D/CX	WRX	RDX	D17-8	D7	D6	D5	D4	D3	D2	D1	D0	HEX												
NOP	0	↑	1	-	0	0	0	0	0	0	0	0	(00h)												
Parameter	No Parameter												-												
Description	This command is empty command. "-" Don't care																								
Restriction																									
Register Availability	<table border="1"> <thead> <tr> <th>Status</th> <th>Availability</th> </tr> </thead> <tbody> <tr> <td>Normal Mode On, Idle Mode Off, Sleep Out</td> <td>Yes</td> </tr> <tr> <td>Normal Mode On, Idle Mode On, Sleep Out</td> <td>Yes</td> </tr> <tr> <td>Partial Mode On, Idle Mode Off, Sleep Out</td> <td>Yes</td> </tr> <tr> <td>Partial Mode On, Idle Mode On, Sleep Out</td> <td>Yes</td> </tr> <tr> <td>Sleep In</td> <td>Yes</td> </tr> </tbody> </table>													Status	Availability	Normal Mode On, Idle Mode Off, Sleep Out	Yes	Normal Mode On, Idle Mode On, Sleep Out	Yes	Partial Mode On, Idle Mode Off, Sleep Out	Yes	Partial Mode On, Idle Mode On, Sleep Out	Yes	Sleep In	Yes
Status	Availability																								
Normal Mode On, Idle Mode Off, Sleep Out	Yes																								
Normal Mode On, Idle Mode On, Sleep Out	Yes																								
Partial Mode On, Idle Mode Off, Sleep Out	Yes																								
Partial Mode On, Idle Mode On, Sleep Out	Yes																								
Sleep In	Yes																								
Default	<table border="1"> <thead> <tr> <th>Status</th> <th>Default Value</th> </tr> </thead> <tbody> <tr> <td>Power On Sequence</td> <td>N/A</td> </tr> <tr> <td>S/W Reset</td> <td>N/A</td> </tr> <tr> <td>H/W Reset</td> <td>N/A</td> </tr> </tbody> </table>													Status	Default Value	Power On Sequence	N/A	S/W Reset	N/A	H/W Reset	N/A				
Status	Default Value																								
Power On Sequence	N/A																								
S/W Reset	N/A																								
H/W Reset	N/A																								
Flow Chart																									

- SWRESET (01h): Software Reset

01H	SWRESET (Software Reset)												
Inst / Para	D/CX	WRX	RDX	D17-8	D7	D6	D5	D4	D3	D2	D1	D0	HEX
SWRESET	0	↑	1	-	0	0	0	0	0	0	0	1	(01h)
Parameter	No Parameter												-
Description	<p>"-" Don't care</p> <ul style="list-style-type: none"> - When the Software Reset command is written, it causes software reset. It resets the commands and parameters to their S/W Reset default values. - Frame memory contents are unaffected by this command. 												
Restriction	<p>It will be necessary to wait 5msec before sending new command following software reset.</p> <p>The display module loads all display suppliers' factory default values to the registers during this 5msec.</p> <p>If software reset is sent during sleep in mode, it will be necessary to wait 120msec before sending sleep out command.</p>												

Software reset command cannot be sent during sleep out sequence.

Register Availability

Status	Availability
Normal Mode On, Idle Mode Off, Sleep Out	Yes
Normal Mode On, Idle Mode On, Sleep Out	Yes
Partial Mode On, Idle Mode Off, Sleep Out	Yes
Partial Mode On, Idle Mode On, Sleep Out	Yes
Sleep In	Yes

Default

Status	Default Value
Power On Sequence	N/A
S/W Reset	N/A
H/W Reset	N/A

Flow Chart

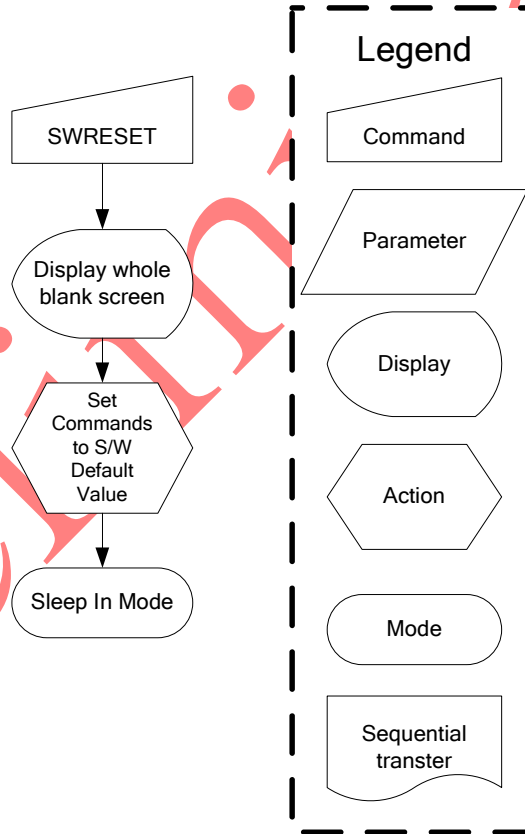

● RDDID (04h): Read Display ID

04H	RDDID (Read Display ID)																															
Inst / Para	D/CX	WRX	RDX	D17-8	D7	D6	D5	D4	D3	D2	D1	D0	HEX																			
RDDID	0	↑	1	-	0	0	0	0	0	1	0	0	(04h)																			
1 st parameter	1	1	↑	-	ID1.7-0							-																				
2 nd parameter	1	1	↑	-	ID2.7-0							-																				
3 rd parameter	1	1	↑	-	ID3.7-0							-																				
Description	<p>- The 1st parameter LCD module's manufacturer ID. - The 2nd parameter LCD module/driver version ID - The 3rd parameter LCD module/driver ID. - Commands RDID1/2/3(Dah, DBh, DCh) read data correspond to the parameters 1,2,3 of the command 04h, respectively. "- " Don't care</p>																															
Restriction																																
Register availability	<table border="1"> <thead> <tr> <th>Status</th> <th>Availability</th> </tr> </thead> <tbody> <tr> <td>Normal Mode On, Idle Mode Off, Sleep Out</td> <td>Yes</td> </tr> <tr> <td>Normal Mode On, Idle Mode On, Sleep Out</td> <td>Yes</td> </tr> <tr> <td>Partial Mode On, Idle Mode Off, Sleep Out</td> <td>Yes</td> </tr> <tr> <td>Partial Mode On, Idle Mode On, Sleep Out</td> <td>Yes</td> </tr> <tr> <td>Sleep In</td> <td>Yes</td> </tr> </tbody> </table>													Status	Availability	Normal Mode On, Idle Mode Off, Sleep Out	Yes	Normal Mode On, Idle Mode On, Sleep Out	Yes	Partial Mode On, Idle Mode Off, Sleep Out	Yes	Partial Mode On, Idle Mode On, Sleep Out	Yes	Sleep In	Yes							
Status	Availability																															
Normal Mode On, Idle Mode Off, Sleep Out	Yes																															
Normal Mode On, Idle Mode On, Sleep Out	Yes																															
Partial Mode On, Idle Mode Off, Sleep Out	Yes																															
Partial Mode On, Idle Mode On, Sleep Out	Yes																															
Sleep In	Yes																															
Default	<table border="1"> <thead> <tr> <th rowspan="2">Status</th> <th colspan="3">Default Value</th> </tr> <tr> <th>ID1</th> <th>ID2</th> <th>ID3</th> </tr> </thead> <tbody> <tr> <td>Power On Sequence</td> <td>See description</td> <td>See description</td> <td>See description</td> </tr> <tr> <td>S/W Reset</td> <td>See description</td> <td>See description</td> <td>See description</td> </tr> <tr> <td>H/W Reset</td> <td>See description</td> <td>See description</td> <td>See description</td> </tr> </tbody> </table>													Status	Default Value			ID1	ID2	ID3	Power On Sequence	See description	See description	See description	S/W Reset	See description	See description	See description	H/W Reset	See description	See description	See description
Status	Default Value																															
	ID1	ID2	ID3																													
Power On Sequence	See description	See description	See description																													
S/W Reset	See description	See description	See description																													
H/W Reset	See description	See description	See description																													

● RDDST (09h): Read Display Status

09H	RDDST (Read Display Status)												
Inst / Para	D/CX	WRX	RDX	D17-8	D7	D6	D5	D4	D3	D2	D1	D0	HEX
RDDST	0	↑	1	-	0	0	0	0	1	0	0	1	(09h)
1 st parameter	1	1	↑	-	BSTON	-	-	-	ML	BGR	MH	-	00-
2 nd parameter	1	1	↑	-	-	DBI.2-0			IDMON	-	SLOUT	-	60
3 rd parameter	1	1	↑	-	-	-	INVON	-	-	DISON	TEON	-	00
4 th parameter	1	1	↑	-	-	-	TEM	-	-	-	-	-	00
Description	This command indicates the current status of the display as described in the table below:												
	Bit	Description		Value									
	BSTON	Booster Voltage Status		'1' =Booster on, '0' =Booster off									
	ML	Scan Address Order (ML)		'0' =Decrement, (LCD refresh Top to Bottom, when MADCTL (36h) D4='0') '1' =Increment, (LCD refresh Bottom to Top, when MADCTL (36h) D4='1')									
	BGR	RGB/ BGR Order (RGB)		'1' =BGR, (When MADCTL (36h) D3='1') '0' =RGB, (When MADCTL (36h) D3='0')									
	IDMON(D19)	Idle Mode On/Off		'1' = On, "0" = Off									
	SLPOUT(D17)	Sleep In/Out		'1' = Out, "0" = In									
	DBI.2-0	Display pixel input format for 1bpp mode		"101": 565 color; "110": 666 color; "111": 888 color									
	INVON(D13)	Inversion Status		'1' = On, "0" = Off									
	DISON(D10)	Display On/Off		'1' = On, "0" = Off									
	TEON(D9)	Tearing effect line on/off		'1' = On, "0" = Off									
TEM(D5)	Tearing effect line mode		'0' = mode1, '1' = mode2										
"- " Don't care													

● RDDPM (0Ah): Read Display Power Mode

0AH	RDDPM (Read Display Power Mode)												HEX												
Inst / Para	D/CX	WRX	RDX	D17-8	D7	D6	D5	D4	D3	D2	D1	D0	HEX												
RDDPM	0	↑	1	-	0	0	0	0	1	0	1	-	(0Ah)												
1 st parameter	1	1	↑	-	BSTON	IDMON	-	SLPOUT	-	DISON	-	-	(00h)												
Description	This command indicates the current status of the display as described in the table below:																								
	Bit	Description										Value													
	BSTON	Booster Voltage Status										'1' =Booster on, '0' =Booster off													
	IDMON	Idle mode on/off										'1' = Idle Mode On, '0' = Idle Mode Off													
	SLPOUT	Sleep in/out										'1' =Sleep out, '0' =Sleep in,													
DISON	Display on/off										'1' =Display on, '0' =Display off,														
“-“ Don't care																									
Register availability	<table border="1"> <thead> <tr> <th>Status</th> <th>Availability</th> </tr> </thead> <tbody> <tr> <td>Normal Mode On, Idle Mode Off, Sleep Out</td> <td>Yes</td> </tr> <tr> <td>Normal Mode On, Idle Mode On, Sleep Out</td> <td>Yes</td> </tr> <tr> <td>Partial Mode On, Idle Mode Off, Sleep Out</td> <td>Yes</td> </tr> <tr> <td>Partial Mode On, Idle Mode On, Sleep Out</td> <td>Yes</td> </tr> <tr> <td>Sleep In</td> <td>Yes</td> </tr> </tbody> </table>													Status	Availability	Normal Mode On, Idle Mode Off, Sleep Out	Yes	Normal Mode On, Idle Mode On, Sleep Out	Yes	Partial Mode On, Idle Mode Off, Sleep Out	Yes	Partial Mode On, Idle Mode On, Sleep Out	Yes	Sleep In	Yes
	Status	Availability																							
	Normal Mode On, Idle Mode Off, Sleep Out	Yes																							
	Normal Mode On, Idle Mode On, Sleep Out	Yes																							
	Partial Mode On, Idle Mode Off, Sleep Out	Yes																							
	Partial Mode On, Idle Mode On, Sleep Out	Yes																							
Sleep In	Yes																								
Default	<table border="1"> <thead> <tr> <th>Status</th> <th>Default Value (D7 to D0)</th> </tr> </thead> <tbody> <tr> <td>Power On Sequence</td> <td>0000-1000(08h)</td> </tr> <tr> <td>S/W Reset</td> <td>0000-1000(08h)</td> </tr> <tr> <td>H/W Reset</td> <td>0000-1000(08h)</td> </tr> </tbody> </table>													Status	Default Value (D7 to D0)	Power On Sequence	0000-1000(08h)	S/W Reset	0000-1000(08h)	H/W Reset	0000-1000(08h)				
	Status	Default Value (D7 to D0)																							
	Power On Sequence	0000-1000(08h)																							
	S/W Reset	0000-1000(08h)																							
H/W Reset	0000-1000(08h)																								

● RDDMADCTL (0Bh): Read Display MADCTL

0BH	RDDMADCTL (Read Display MADCTL)																								
Inst / Para	D/CX	WRX	RDX	D17-8	D7	D6	D5	D4	D3	D2	D1	D0	HEX												
RDDMADCTL	0	↑	1	-	0	0	0	0	1	0	1	1	(0Bh)												
1 st parameter	1	1	↑	-	-	-	-	ML	RGB	MH	-	-	(00h)												
Description	This command indicates the current status of the display as described in the table below:																								
	Bit	Description										Value													
	ML	Scan Address Order (ML)										'0' =Decrement, (LCD refresh Top to Bottom, when MADCTL (36h) D4='0') '1'=Increment, (LCD refresh Bottom to Top, when MADCTL (36h) D4='1')													
	RGB	RGB/ BGR Order (RGB)										'1' =BGR, (When MADCTL (36h) D3='1') '0' =RGB, (When MADCTL (36h) D3='0')													
	MH	Horizontal Order										'0' =Decrement, (LCD refresh Left to Right, when MADCTL (36h) D2='0') '1' =Increment, (LCD refresh Right to Left, when MADCTL (36h) D2='1')													
	D1	Not used										'0'													
D0	Not used										'0'														
“-“ Don't care																									
Restriction	There is one dummy parameter when using Parallel interface.																								
Register availability	<table border="1"> <thead> <tr> <th>Status</th> <th>Availability</th> </tr> </thead> <tbody> <tr> <td>Normal Mode On, Idle Mode Off, Sleep Out</td> <td>Yes</td> </tr> <tr> <td>Normal Mode On, Idle Mode On, Sleep Out</td> <td>Yes</td> </tr> <tr> <td>Partial Mode On, Idle Mode Off, Sleep Out</td> <td>Yes</td> </tr> <tr> <td>Partial Mode On, Idle Mode On, Sleep Out</td> <td>Yes</td> </tr> <tr> <td>Sleep In</td> <td>Yes</td> </tr> </tbody> </table>													Status	Availability	Normal Mode On, Idle Mode Off, Sleep Out	Yes	Normal Mode On, Idle Mode On, Sleep Out	Yes	Partial Mode On, Idle Mode Off, Sleep Out	Yes	Partial Mode On, Idle Mode On, Sleep Out	Yes	Sleep In	Yes
	Status	Availability																							
	Normal Mode On, Idle Mode Off, Sleep Out	Yes																							
	Normal Mode On, Idle Mode On, Sleep Out	Yes																							
	Partial Mode On, Idle Mode Off, Sleep Out	Yes																							
	Partial Mode On, Idle Mode On, Sleep Out	Yes																							
Sleep In	Yes																								
Default	<table border="1"> <thead> <tr> <th>Status</th> <th>Default Value (D7 to D0)</th> </tr> </thead> <tbody> <tr> <td>Power On Sequence</td> <td>0000-0000 (00h)</td> </tr> <tr> <td>S/W Reset</td> <td>No change</td> </tr> <tr> <td>H/W Reset</td> <td>0000-0000 (00h)</td> </tr> </tbody> </table>													Status	Default Value (D7 to D0)	Power On Sequence	0000-0000 (00h)	S/W Reset	No change	H/W Reset	0000-0000 (00h)				
	Status	Default Value (D7 to D0)																							
	Power On Sequence	0000-0000 (00h)																							
	S/W Reset	No change																							
H/W Reset	0000-0000 (00h)																								

● RDDCOLMOD (0Ch): Read Display Pixel Format

0Ch	RDDCOLMOD (Read Display Pixel Format)												HEX											
Inst / Para	D/CX	WRX	RDX	D17-8	D7	D6	D5	D4	D3	D2	D1	D0	HEX											
RDDCOLMOD	0	↑	1	-	0	0	0	0	1	1	0	0	(0Ch)											
1 st parameter	1	1	↑	-	-	-	-	-	-	DBI.2-0		(06h)												
Description	DBI.2-0: Display pixel input format for 1bpp mode. "101": 565 color; "110": 666 color; "111": 888 color. Others are no define and invalid "-" Don't care																							
Restriction	There is one dummy parameter when using Parallel interface.																							
Register availability	<table border="1"> <thead> <tr> <th>Status</th> <th>Availability</th> </tr> </thead> <tbody> <tr> <td>Normal Mode On, Idle Mode Off, Sleep Out</td> <td>Yes</td> </tr> <tr> <td>Normal Mode On, Idle Mode On, Sleep Out</td> <td>Yes</td> </tr> <tr> <td>Partial Mode On, Idle Mode Off, Sleep Out</td> <td>Yes</td> </tr> <tr> <td>Partial Mode On, Idle Mode On, Sleep Out</td> <td>Yes</td> </tr> <tr> <td>Sleep In</td> <td>Yes</td> </tr> </tbody> </table>												Status	Availability	Normal Mode On, Idle Mode Off, Sleep Out	Yes	Normal Mode On, Idle Mode On, Sleep Out	Yes	Partial Mode On, Idle Mode Off, Sleep Out	Yes	Partial Mode On, Idle Mode On, Sleep Out	Yes	Sleep In	Yes
Status	Availability																							
Normal Mode On, Idle Mode Off, Sleep Out	Yes																							
Normal Mode On, Idle Mode On, Sleep Out	Yes																							
Partial Mode On, Idle Mode Off, Sleep Out	Yes																							
Partial Mode On, Idle Mode On, Sleep Out	Yes																							
Sleep In	Yes																							
Default	<table border="1"> <thead> <tr> <th>Status</th> <th>Default Value</th> </tr> </thead> <tbody> <tr> <td>Power On Sequence</td> <td>0000-0110 (18 bit/pixel)</td> </tr> <tr> <td>S/W Reset</td> <td>No change</td> </tr> <tr> <td>H/W Reset</td> <td>0000-0110 (18 bit/pixel)</td> </tr> </tbody> </table>												Status	Default Value	Power On Sequence	0000-0110 (18 bit/pixel)	S/W Reset	No change	H/W Reset	0000-0110 (18 bit/pixel)				
Status	Default Value																							
Power On Sequence	0000-0110 (18 bit/pixel)																							
S/W Reset	No change																							
H/W Reset	0000-0110 (18 bit/pixel)																							

● RDDIM (0Dh): Read Display Image Mode

0DH	RDDIM (Read Display Image Mode)																																																									
Inst / Para	D/CX	WRX	RDX	D17-8	D7	D6	D5	D4	D3	D2	D1	D0	HEX																																													
RDDIM	0	↑	1	-	0	0	0	0	1	1	0	1	(0Dh)																																													
1 st parameter	1	1	↑	-	-	-	INVON	-	-	-	-	-	(00h)																																													
Description	<p>This command indicates the current status of the display as described in the table below:</p> <p>-INVON: Inversion on/off</p> <table border="1"> <thead> <tr> <th>Gamma Curve Selection</th> <th>GC2</th> <th>GC1</th> <th>GC0</th> <th>Gamma set (26h) Parameter</th> </tr> </thead> <tbody> <tr> <td>Gamma curve 1</td> <td>0</td> <td>0</td> <td>0</td> <td>GC0</td> </tr> <tr> <td>Gamma curve 2</td> <td>0</td> <td>0</td> <td>1</td> <td>GC1</td> </tr> <tr> <td>Gamma curve 3</td> <td>0</td> <td>1</td> <td>0</td> <td>GC2</td> </tr> <tr> <td>Gamma curve 4</td> <td>0</td> <td>1</td> <td>1</td> <td>GC3</td> </tr> <tr> <td>Not Defined</td> <td>1</td> <td>0</td> <td>0</td> <td>Not Defined</td> </tr> <tr> <td>Not Defined</td> <td>1</td> <td>0</td> <td>1</td> <td>Not Defined</td> </tr> <tr> <td>Not Defined</td> <td>1</td> <td>1</td> <td>0</td> <td>Not Defined</td> </tr> <tr> <td>Not Defined</td> <td>1</td> <td>1</td> <td>1</td> <td>Not Defined</td> </tr> </tbody> </table> <p>Others are no define and invalid "- " Don't care</p>													Gamma Curve Selection	GC2	GC1	GC0	Gamma set (26h) Parameter	Gamma curve 1	0	0	0	GC0	Gamma curve 2	0	0	1	GC1	Gamma curve 3	0	1	0	GC2	Gamma curve 4	0	1	1	GC3	Not Defined	1	0	0	Not Defined	Not Defined	1	0	1	Not Defined	Not Defined	1	1	0	Not Defined	Not Defined	1	1	1	Not Defined
	Gamma Curve Selection	GC2	GC1	GC0	Gamma set (26h) Parameter																																																					
	Gamma curve 1	0	0	0	GC0																																																					
	Gamma curve 2	0	0	1	GC1																																																					
	Gamma curve 3	0	1	0	GC2																																																					
	Gamma curve 4	0	1	1	GC3																																																					
	Not Defined	1	0	0	Not Defined																																																					
	Not Defined	1	0	1	Not Defined																																																					
	Not Defined	1	1	0	Not Defined																																																					
	Not Defined	1	1	1	Not Defined																																																					
Restriction	There is one dummy parameter when using Parallel interface.																																																									
Register availability	<table border="1"> <thead> <tr> <th>Status</th> <th>Availability</th> </tr> </thead> <tbody> <tr> <td>Normal Mode On, Idle Mode Off, Sleep Out</td> <td>Yes</td> </tr> <tr> <td>Normal Mode On, Idle Mode On, Sleep Out</td> <td>Yes</td> </tr> <tr> <td>Partial Mode On, Idle Mode Off, Sleep Out</td> <td>Yes</td> </tr> <tr> <td>Partial Mode On, Idle Mode On, Sleep Out</td> <td>Yes</td> </tr> <tr> <td>Sleep In</td> <td>Yes</td> </tr> </tbody> </table>													Status	Availability	Normal Mode On, Idle Mode Off, Sleep Out	Yes	Normal Mode On, Idle Mode On, Sleep Out	Yes	Partial Mode On, Idle Mode Off, Sleep Out	Yes	Partial Mode On, Idle Mode On, Sleep Out	Yes	Sleep In	Yes																																	
	Status	Availability																																																								
	Normal Mode On, Idle Mode Off, Sleep Out	Yes																																																								
	Normal Mode On, Idle Mode On, Sleep Out	Yes																																																								
	Partial Mode On, Idle Mode Off, Sleep Out	Yes																																																								
	Partial Mode On, Idle Mode On, Sleep Out	Yes																																																								
Sleep In	Yes																																																									
Default	<table border="1"> <thead> <tr> <th>Status</th> <th>Default Value</th> </tr> </thead> <tbody> <tr> <td>Power On Sequence</td> <td>0000-0000</td> </tr> <tr> <td>S/W Reset</td> <td>0000-0000</td> </tr> <tr> <td>H/W Reset</td> <td>0000-0000</td> </tr> </tbody> </table>													Status	Default Value	Power On Sequence	0000-0000	S/W Reset	0000-0000	H/W Reset	0000-0000																																					
	Status	Default Value																																																								
	Power On Sequence	0000-0000																																																								
	S/W Reset	0000-0000																																																								
H/W Reset	0000-0000																																																									

● RDDSM (0Eh): Read Display Signal Mode

0EH	RDDSM (Read Display Signal Status)												HEX																				
Inst / Para	D/CX	WRX	RDX	D17-8	D7	D6	D5	D4	D3	D2	D1	D0	HEX																				
RDDSM	0	↑	1	-	0	0	0	0	1	1	1	0	(0Eh)																				
1 st parameter	1	1	↑	-	TEON	TEM	HS	VS	PixelClk	DataEn	0	0	(00h)-																				
Description	This command indicates the current status of the display as described in the table below:																																
	<table border="1"> <thead> <tr> <th>Bit</th> <th>Description</th> <th>Value</th> </tr> </thead> <tbody> <tr> <td>TEON</td> <td>Tearing effect line on/off</td> <td>'1' = ON, '0' = OFF,</td> </tr> <tr> <td>TEM</td> <td>Tearing effect line mode</td> <td>'1' = mode2, '0' = mode1,</td> </tr> <tr> <td>HS</td> <td>Horizontal Sync (RGB interface)</td> <td>'1' = ON, '0' = OFF,</td> </tr> <tr> <td>VS</td> <td>Vertical Sync (RGB interface)</td> <td>'1' = ON, '0' = OFF,</td> </tr> <tr> <td>PixelClk</td> <td>Pixel Clock (DOTCLK, RGB interface)</td> <td>'1' = ON, '0' = OFF,</td> </tr> <tr> <td>DataEn</td> <td>Data Enable (DE, RGB interface)</td> <td>'1' = ON, '0' = OFF,</td> </tr> </tbody> </table>													Bit	Description	Value	TEON	Tearing effect line on/off	'1' = ON, '0' = OFF,	TEM	Tearing effect line mode	'1' = mode2, '0' = mode1,	HS	Horizontal Sync (RGB interface)	'1' = ON, '0' = OFF,	VS	Vertical Sync (RGB interface)	'1' = ON, '0' = OFF,	PixelClk	Pixel Clock (DOTCLK, RGB interface)	'1' = ON, '0' = OFF,	DataEn	Data Enable (DE, RGB interface)
Bit	Description	Value																															
TEON	Tearing effect line on/off	'1' = ON, '0' = OFF,																															
TEM	Tearing effect line mode	'1' = mode2, '0' = mode1,																															
HS	Horizontal Sync (RGB interface)	'1' = ON, '0' = OFF,																															
VS	Vertical Sync (RGB interface)	'1' = ON, '0' = OFF,																															
PixelClk	Pixel Clock (DOTCLK, RGB interface)	'1' = ON, '0' = OFF,																															
DataEn	Data Enable (DE, RGB interface)	'1' = ON, '0' = OFF,																															
	"- " Don't care																																
Restriction	There is one dummy parameter when using Parallel interface.																																
Register availability	<table border="1"> <thead> <tr> <th>Status</th> <th>Availability</th> </tr> </thead> <tbody> <tr> <td>Normal Mode On, Idle Mode Off, Sleep Out</td> <td>Yes</td> </tr> <tr> <td>Normal Mode On, Idle Mode On, Sleep Out</td> <td>Yes</td> </tr> <tr> <td>Partial Mode On, Idle Mode Off, Sleep Out</td> <td>Yes</td> </tr> <tr> <td>Partial Mode On, Idle Mode On, Sleep Out</td> <td>Yes</td> </tr> <tr> <td>Sleep In</td> <td>Yes</td> </tr> </tbody> </table>													Status	Availability	Normal Mode On, Idle Mode Off, Sleep Out	Yes	Normal Mode On, Idle Mode On, Sleep Out	Yes	Partial Mode On, Idle Mode Off, Sleep Out	Yes	Partial Mode On, Idle Mode On, Sleep Out	Yes	Sleep In	Yes								
	Status	Availability																															
Normal Mode On, Idle Mode Off, Sleep Out	Yes																																
Normal Mode On, Idle Mode On, Sleep Out	Yes																																
Partial Mode On, Idle Mode Off, Sleep Out	Yes																																
Partial Mode On, Idle Mode On, Sleep Out	Yes																																
Sleep In	Yes																																
Default	<table border="1"> <thead> <tr> <th>Status</th> <th>Default Value</th> </tr> </thead> <tbody> <tr> <td>Power On Sequence</td> <td>0000-0000</td> </tr> <tr> <td>S/W Reset</td> <td>0000-0000</td> </tr> <tr> <td>H/W Reset</td> <td>0000-0000</td> </tr> </tbody> </table>													Status	Default Value	Power On Sequence	0000-0000	S/W Reset	0000-0000	H/W Reset	0000-0000												
Status	Default Value																																
Power On Sequence	0000-0000																																
S/W Reset	0000-0000																																
H/W Reset	0000-0000																																

● RDDSDR (0Fh): Read Display Self-Diagnostic Result

0FH	RDDSDR (Read Display Self-Diagnostic Result)												HEX												
Inst / Para	D/CX	WRX	RDX	D17-8	D7	D6	D5	D4	D3	D2	D1	D0	HEX												
RDDSDR	0	↑	1	-	0	0	0	0	1	1	1	1	(0Fh)												
1 st parameter	1	1	↑	-	RELD	FUND	-	-	-	-	-	CSCMP	(00h)												
Description	This command indicates the current status of the display self-diagnostic result after sleep out command as described below: -CSCMP: Checksum comparison: '0' checksum the same; '1': checksum not the same. "-" Don't care																								
Restriction	There is one dummy parameter when using Parallel interface.																								
Register availability	<table border="1"> <thead> <tr> <th>Status</th> <th>Availability</th> </tr> </thead> <tbody> <tr> <td>Normal Mode On, Idle Mode Off, Sleep Out</td> <td>Yes</td> </tr> <tr> <td>Normal Mode On, Idle Mode On, Sleep Out</td> <td>Yes</td> </tr> <tr> <td>Partial Mode On, Idle Mode Off, Sleep Out</td> <td>Yes</td> </tr> <tr> <td>Partial Mode On, Idle Mode On, Sleep Out</td> <td>Yes</td> </tr> <tr> <td>Sleep In</td> <td>Yes</td> </tr> </tbody> </table>													Status	Availability	Normal Mode On, Idle Mode Off, Sleep Out	Yes	Normal Mode On, Idle Mode On, Sleep Out	Yes	Partial Mode On, Idle Mode Off, Sleep Out	Yes	Partial Mode On, Idle Mode On, Sleep Out	Yes	Sleep In	Yes
Status	Availability																								
Normal Mode On, Idle Mode Off, Sleep Out	Yes																								
Normal Mode On, Idle Mode On, Sleep Out	Yes																								
Partial Mode On, Idle Mode Off, Sleep Out	Yes																								
Partial Mode On, Idle Mode On, Sleep Out	Yes																								
Sleep In	Yes																								
Default	<table border="1"> <thead> <tr> <th>Status</th> <th>Default Value</th> </tr> </thead> <tbody> <tr> <td>Power On Sequence</td> <td>0000-0000</td> </tr> <tr> <td>S/W Reset</td> <td>0000-0000</td> </tr> <tr> <td>H/W Reset</td> <td>0000-0000</td> </tr> </tbody> </table>													Status	Default Value	Power On Sequence	0000-0000	S/W Reset	0000-0000	H/W Reset	0000-0000				
Status	Default Value																								
Power On Sequence	0000-0000																								
S/W Reset	0000-0000																								
H/W Reset	0000-0000																								

● RDFCS (Aah): Read First Checksum

AAH	RDFCS (Read First Checksum)												HEX
Inst / Para	D/CX	WRX	RDX	D17-8	D7	D6	D5	D4	D3	D2	D1	D0	HEX
RDID1	0	↑	1	-	1	0	1	0	1	0	1	0	(Aah)
1 st parameter	1	1	↑	-	FCS.7-0							-	
Description	- This command returns the first checksum what has been calculated from User's area registers and the frame memory after the write access to those registers and/or frame memory has been done. X = can be '0' or '1'												
Restriction	It will be necessary to wait 150ms after there is the last write access on User area registers before there can read this checksum value.												

Register availability	<table border="1"> <thead> <tr> <th>Status</th> <th>Availability</th> </tr> </thead> <tbody> <tr> <td>Normal Mode On, Idle Mode Off, Sleep Out</td> <td>Yes</td> </tr> <tr> <td>Normal Mode On, Idle Mode On, Sleep Out</td> <td>Yes</td> </tr> <tr> <td>Partial Mode On, Idle Mode Off, Sleep Out</td> <td>Yes</td> </tr> <tr> <td>Partial Mode On, Idle Mode On, Sleep Out</td> <td>Yes</td> </tr> <tr> <td>Sleep In</td> <td>Yes</td> </tr> </tbody> </table>	Status	Availability	Normal Mode On, Idle Mode Off, Sleep Out	Yes	Normal Mode On, Idle Mode On, Sleep Out	Yes	Partial Mode On, Idle Mode Off, Sleep Out	Yes	Partial Mode On, Idle Mode On, Sleep Out	Yes	Sleep In	Yes
	Status	Availability											
	Normal Mode On, Idle Mode Off, Sleep Out	Yes											
	Normal Mode On, Idle Mode On, Sleep Out	Yes											
	Partial Mode On, Idle Mode Off, Sleep Out	Yes											
Partial Mode On, Idle Mode On, Sleep Out	Yes												
Sleep In	Yes												
Default	<table border="1"> <thead> <tr> <th>Status</th> <th>Default Value</th> </tr> </thead> <tbody> <tr> <td>Power On Sequence</td> <td>00h</td> </tr> <tr> <td>S/W Reset</td> <td>00h</td> </tr> <tr> <td>H/W Reset</td> <td>00h</td> </tr> </tbody> </table>	Status	Default Value	Power On Sequence	00h	S/W Reset	00h	H/W Reset	00h				
Status	Default Value												
Power On Sequence	00h												
S/W Reset	00h												
H/W Reset	00h												

● RDCFCS (Afh): Read Continue Checksum

AFH	RDCFCS (Read Continue Checksum)												HEX
Inst / Para	D/CX	WRX	RDX	D17-8	D7	D6	D5	D4	D3	D2	D1	D0	HEX
RDID1	0	↑	1	-	1	0	1	0	1	1	1	1	(Afh)
1 st parameter	1	1	↑	-	CCS.7-0							-	
Description	<p>- This command returns the continue checksum what has been calculated continuously after the first checksum has calculated from User's area registers and the frame memory after the write access to those registers and/or frame memory has been done.</p> <p>X = can be '0' or '1'</p>												
Restriction	<p>It will be necessary to wait 300ms after there is the last write access on User area registers before there can read this checksum value in the first time..</p>												
Register availability	<table border="1"> <thead> <tr> <th>Status</th> <th>Availability</th> </tr> </thead> <tbody> <tr> <td>Normal Mode On, Idle Mode Off, Sleep Out</td> <td>Yes</td> </tr> <tr> <td>Normal Mode On, Idle Mode On, Sleep Out</td> <td>Yes</td> </tr> <tr> <td>Partial Mode On, Idle Mode Off, Sleep Out</td> <td>Yes</td> </tr> <tr> <td>Partial Mode On, Idle Mode On, Sleep Out</td> <td>Yes</td> </tr> <tr> <td>Sleep In</td> <td>Yes</td> </tr> </tbody> </table>	Status	Availability	Normal Mode On, Idle Mode Off, Sleep Out	Yes	Normal Mode On, Idle Mode On, Sleep Out	Yes	Partial Mode On, Idle Mode Off, Sleep Out	Yes	Partial Mode On, Idle Mode On, Sleep Out	Yes	Sleep In	Yes
	Status	Availability											
	Normal Mode On, Idle Mode Off, Sleep Out	Yes											
	Normal Mode On, Idle Mode On, Sleep Out	Yes											
	Partial Mode On, Idle Mode Off, Sleep Out	Yes											
Partial Mode On, Idle Mode On, Sleep Out	Yes												
Sleep In	Yes												
Default	<table border="1"> <thead> <tr> <th>Status</th> <th>Default Value</th> </tr> </thead> <tbody> <tr> <td>Power On Sequence</td> <td>00h</td> </tr> <tr> <td>H/W Reset</td> <td>00h</td> </tr> </tbody> </table>	Status	Default Value	Power On Sequence	00h	H/W Reset	00h						
Status	Default Value												
Power On Sequence	00h												
H/W Reset	00h												

● RDID1 (Dah): Read ID1

DAH	RDID1 (Read ID1)																								
Inst / Para	D/CX	WRX	RDX	D17-8	D7	D6	D5	D4	D3	D2	D1	D0	HEX												
RDID1	0	↑	1	-	1	1	0	1	1	0	1	0	(Dah)												
parameter	1	1	↑	-	ID1.7-0							-													
Description	-This read byte identifies the LCD module's manufacturer. '-': Don't care.																								
Register availability	<table border="1"> <thead> <tr> <th>Status</th> <th>Availability</th> </tr> </thead> <tbody> <tr> <td>Normal Mode On, Idle Mode Off, Sleep Out</td> <td>Yes</td> </tr> <tr> <td>Normal Mode On, Idle Mode On, Sleep Out</td> <td>Yes</td> </tr> <tr> <td>Partial Mode On, Idle Mode Off, Sleep Out</td> <td>Yes</td> </tr> <tr> <td>Partial Mode On, Idle Mode On, Sleep Out</td> <td>Yes</td> </tr> <tr> <td>Sleep In</td> <td>Yes</td> </tr> </tbody> </table>													Status	Availability	Normal Mode On, Idle Mode Off, Sleep Out	Yes	Normal Mode On, Idle Mode On, Sleep Out	Yes	Partial Mode On, Idle Mode Off, Sleep Out	Yes	Partial Mode On, Idle Mode On, Sleep Out	Yes	Sleep In	Yes
Status	Availability																								
Normal Mode On, Idle Mode Off, Sleep Out	Yes																								
Normal Mode On, Idle Mode On, Sleep Out	Yes																								
Partial Mode On, Idle Mode Off, Sleep Out	Yes																								
Partial Mode On, Idle Mode On, Sleep Out	Yes																								
Sleep In	Yes																								
Default	<table border="1"> <thead> <tr> <th>Status</th> <th>Default Value</th> </tr> </thead> <tbody> <tr> <td>Power On Sequence</td> <td>00h</td> </tr> <tr> <td>S/W Reset</td> <td>00h</td> </tr> <tr> <td>H/W Reset</td> <td>00h</td> </tr> </tbody> </table>													Status	Default Value	Power On Sequence	00h	S/W Reset	00h	H/W Reset	00h				
Status	Default Value																								
Power On Sequence	00h																								
S/W Reset	00h																								
H/W Reset	00h																								

● RDID2 (DBh): Read ID2

DBH	RDID2 (Read ID2)																								
Inst / Para	D/CX	WRX	RDX	D17-8	D7	D6	D5	D4	D3	D2	D1	D0	HEX												
RDID2	0	↑	1	-	1	1	0	1	1	0	1	1	(DBh)												
1 st parameter	1	1	↑	-	ID2.7-0							-													
Description	This read byte is used to track the LCD module/driver IC version. '-': Don't care.																								
Register availability	<table border="1"> <thead> <tr> <th>Status</th> <th>Availability</th> </tr> </thead> <tbody> <tr> <td>Normal Mode On, Idle Mode Off, Sleep Out</td> <td>Yes</td> </tr> <tr> <td>Normal Mode On, Idle Mode On, Sleep Out</td> <td>Yes</td> </tr> <tr> <td>Partial Mode On, Idle Mode Off, Sleep Out</td> <td>Yes</td> </tr> <tr> <td>Partial Mode On, Idle Mode On, Sleep Out</td> <td>Yes</td> </tr> <tr> <td>Sleep In</td> <td>Yes</td> </tr> </tbody> </table>													Status	Availability	Normal Mode On, Idle Mode Off, Sleep Out	Yes	Normal Mode On, Idle Mode On, Sleep Out	Yes	Partial Mode On, Idle Mode Off, Sleep Out	Yes	Partial Mode On, Idle Mode On, Sleep Out	Yes	Sleep In	Yes
Status	Availability																								
Normal Mode On, Idle Mode Off, Sleep Out	Yes																								
Normal Mode On, Idle Mode On, Sleep Out	Yes																								
Partial Mode On, Idle Mode Off, Sleep Out	Yes																								
Partial Mode On, Idle Mode On, Sleep Out	Yes																								
Sleep In	Yes																								

Default	Status		Default Value
	Power On Sequence		00h
	S/W Reset		00h
	H/W Reset		00h

● RDID3 (DCh): Read ID3

DCH	RDID3 (Read ID3)																								
Inst / Para	D/CX	WRX	RDX	D17-8	D7	D6	D5	D4	D3	D2	D1	D0	HEX												
RDID3	0	↑	1	-	1	1	0	1	1	1	0	0	(DCh)												
1 st parameter	1	1	↑	-	-	ID3.7-0						-													
Description	<i>This read byte identifies the LCD module/driver.</i> ↳: Don't care.																								
Register availability	<table border="1"> <thead> <tr> <th>Status</th> <th>Availability</th> </tr> </thead> <tbody> <tr> <td>Normal Mode On, Idle Mode Off, Sleep Out</td> <td>Yes</td> </tr> <tr> <td>Normal Mode On, Idle Mode On, Sleep Out</td> <td>Yes</td> </tr> <tr> <td>Partial Mode On, Idle Mode Off, Sleep Out</td> <td>Yes</td> </tr> <tr> <td>Partial Mode On, Idle Mode On, Sleep Out</td> <td>Yes</td> </tr> <tr> <td>Sleep In</td> <td>Yes</td> </tr> </tbody> </table>													Status	Availability	Normal Mode On, Idle Mode Off, Sleep Out	Yes	Normal Mode On, Idle Mode On, Sleep Out	Yes	Partial Mode On, Idle Mode Off, Sleep Out	Yes	Partial Mode On, Idle Mode On, Sleep Out	Yes	Sleep In	Yes
Status	Availability																								
Normal Mode On, Idle Mode Off, Sleep Out	Yes																								
Normal Mode On, Idle Mode On, Sleep Out	Yes																								
Partial Mode On, Idle Mode Off, Sleep Out	Yes																								
Partial Mode On, Idle Mode On, Sleep Out	Yes																								
Sleep In	Yes																								
Default	<table border="1"> <thead> <tr> <th>Status</th> <th>Default Value</th> </tr> </thead> <tbody> <tr> <td>Power On Sequence</td> <td>00h</td> </tr> <tr> <td>S/W Reset</td> <td>00h</td> </tr> <tr> <td>H/W Reset</td> <td>00h</td> </tr> </tbody> </table>													Status	Default Value	Power On Sequence	00h	S/W Reset	00h	H/W Reset	00h				
Status	Default Value																								
Power On Sequence	00h																								
S/W Reset	00h																								
H/W Reset	00h																								

● SLPIN (10h): Sleep in

10H	SLPIN (Sleep In)																								
Inst / Para	D/CX	WRX	RDX	D17-8	D7	D6	D5	D4	D3	D2	D1	D0	HEX												
SLPIN	0	↑	1	-	0	0	0	1	0	0	0	0	(10h)												
parameter	No Parameter																								
Description	<p>-This command causes the LCD module to enter the minimum power consumption mode.</p> <p>-In this mode the DC/DC converter is stopped, internal oscillator is stopped, and panel scanning is stopped.</p> <p>-MCU interface and memory are still working and the memory keeps its contents.</p> <p>-Dimming function does not work when there is changing mode from Sleep OUT to Sleep IN.</p> <p>“-“ Don't care</p>																								
Restriction	<p>-This command has no effect when module is already in sleep in mode. Sleep in mode can only be left by the sleep out command (11h).</p> <p>-It will be necessary to wait 5msec before sending any new commands to a display module following this command to allow time for the supply voltages and clock circuits to stabilize.</p> <p>-It will be necessary to wait 120msec after sending sleep out command (when in sleep in mode) before sending an sleep in command.</p>																								
Register availability	<table border="1"> <thead> <tr> <th>Status</th> <th>Availability</th> </tr> </thead> <tbody> <tr> <td>Normal Mode On, Idle Mode Off, Sleep Out</td> <td>Yes</td> </tr> <tr> <td>Normal Mode On, Idle Mode On, Sleep Out</td> <td>Yes</td> </tr> <tr> <td>Partial Mode On, Idle Mode Off, Sleep Out</td> <td>Yes</td> </tr> <tr> <td>Partial Mode On, Idle Mode On, Sleep Out</td> <td>Yes</td> </tr> <tr> <td>Sleep In</td> <td>Yes</td> </tr> </tbody> </table>													Status	Availability	Normal Mode On, Idle Mode Off, Sleep Out	Yes	Normal Mode On, Idle Mode On, Sleep Out	Yes	Partial Mode On, Idle Mode Off, Sleep Out	Yes	Partial Mode On, Idle Mode On, Sleep Out	Yes	Sleep In	Yes
Status	Availability																								
Normal Mode On, Idle Mode Off, Sleep Out	Yes																								
Normal Mode On, Idle Mode On, Sleep Out	Yes																								
Partial Mode On, Idle Mode Off, Sleep Out	Yes																								
Partial Mode On, Idle Mode On, Sleep Out	Yes																								
Sleep In	Yes																								
Default	<table border="1"> <thead> <tr> <th>Status</th> <th>Default Value</th> </tr> </thead> <tbody> <tr> <td>Power On Sequence</td> <td>Sleep in mode</td> </tr> <tr> <td>S/W Reset</td> <td>Sleep in mode</td> </tr> <tr> <td>H/W Reset</td> <td>Sleep in mode</td> </tr> </tbody> </table>													Status	Default Value	Power On Sequence	Sleep in mode	S/W Reset	Sleep in mode	H/W Reset	Sleep in mode				
Status	Default Value																								
Power On Sequence	Sleep in mode																								
S/W Reset	Sleep in mode																								
H/W Reset	Sleep in mode																								

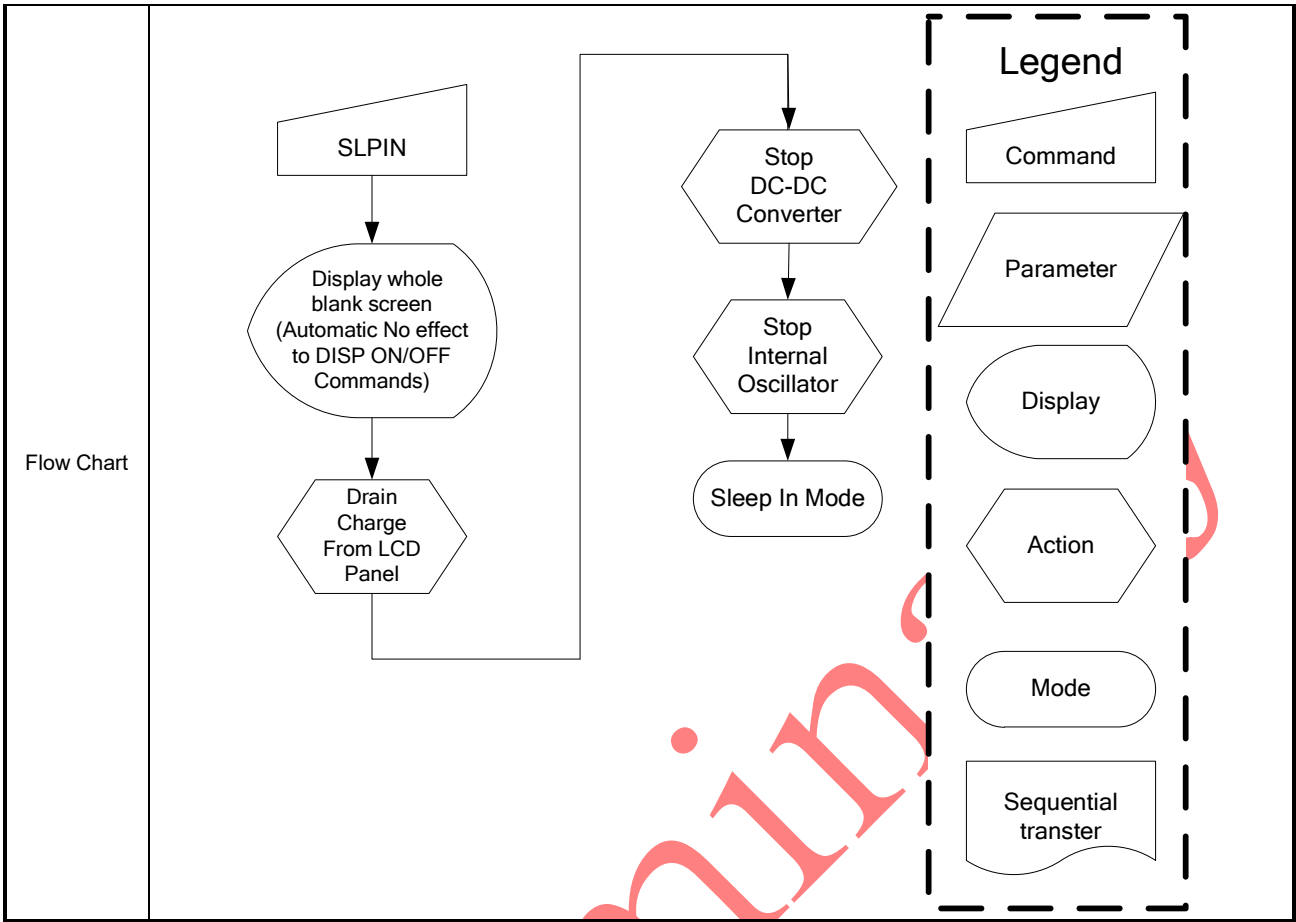

● **SLPOUT (11h): Sleep Out**

11H	SLPOUT (Sleep Out)												HEX
Inst / Para	D/CX	WRX	RDX	D17-8	D7	D6	D5	D4	D3	D2	D1	D0	HEX
SLPOUT	0	↑	1	-	0	0	0	1	0	0	0	1	(11h)
parameter	No Parameter												
Description	<p>-This command turn off sleep mode.</p> <p>-In this mode the DC/DC converter is enabled, internal display oscillator is started, and panel scanning is started.</p>												
Restriction	<p>-This command has no effect when module is already in sleep out mode. Sleep out mode can only be left by the sleep in command (10h).</p> <p>-It will be necessary to wait 5msec before sending any new commands to a display module following this command to allow time for the supply voltages and clock circuits to stabilize.</p> <p>-It will be necessary to wait 120msec after sending sleep out command (when in sleep in mode) before sending an sleep in command.</p> <p>-The display module runs the self-diagnostic functions after this command is received.</p>												
Register availability													

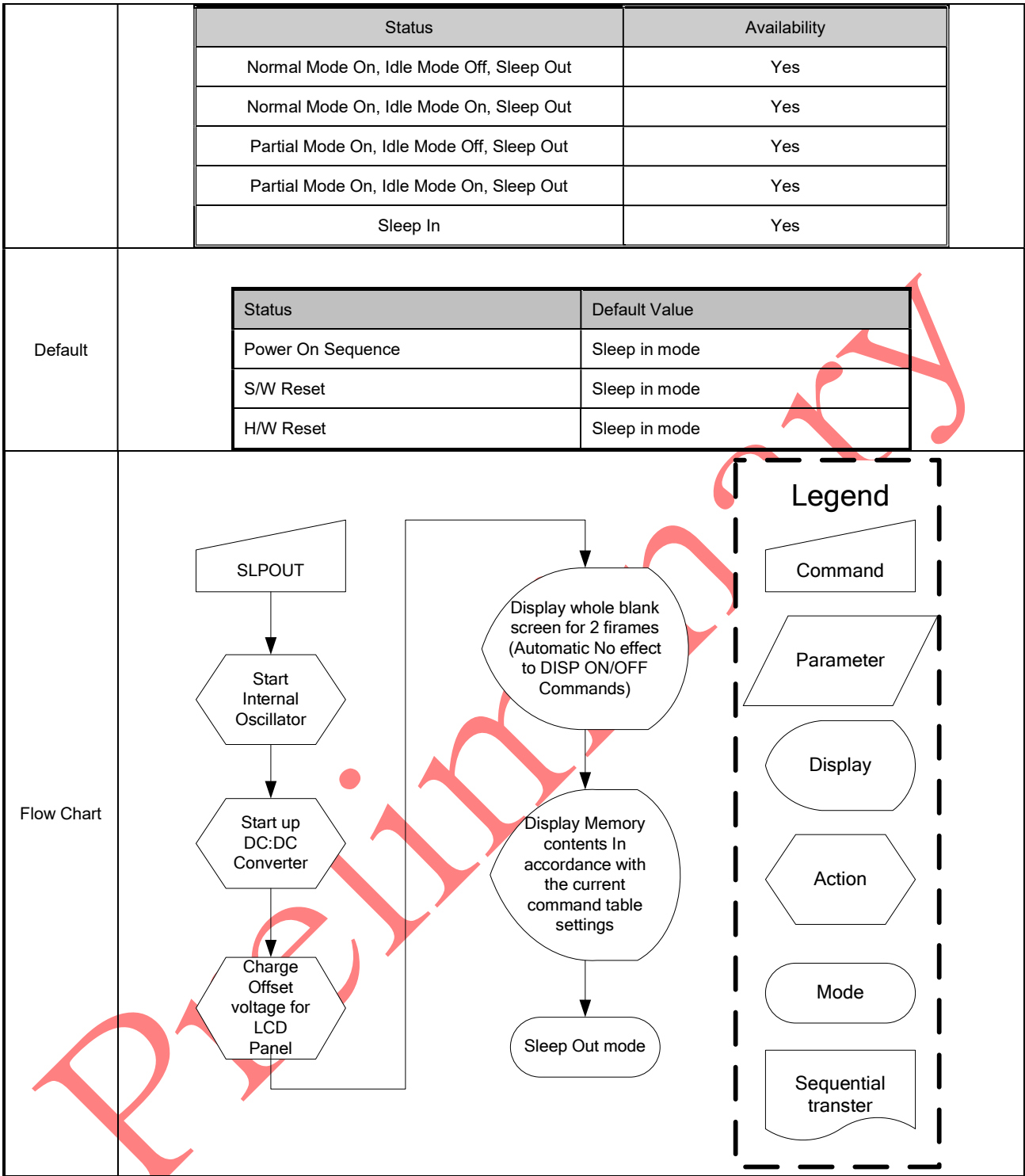

● INVOFF (20h): Display Inversion Off

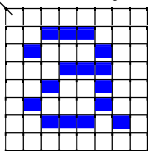
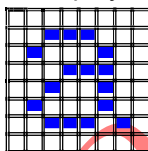
20H	INVOFF (Display Inversion Off)																								
Inst / Para	D/CX	WRX	RDX	D17-8	D7	D6	D5	D4	D3	D2	D1	D0	HEX												
INVOFF	0	↑	1	-	0	0	1	0	0	0	0	0	(20h)												
parameter	No Parameter																								
Description	<p>-This command is used to recover from display inversion mode. “-“ Don't care</p> <p style="text-align: center;">(Example)</p> <div style="display: flex; align-items: center; justify-content: center;"> <div style="text-align: center;"> <p>Top-Left (0,0)</p>  <p>Memory</p> </div> <div style="margin: 0 20px;"> <p>⇒</p> </div> <div style="text-align: center;">  <p>Display</p> </div> </div>																								
Restriction	This command has no effect when module is already in inversion off mode.																								
Register availability	<table border="1" style="width: 100%; border-collapse: collapse;"> <thead> <tr> <th style="width: 50%;">Status</th> <th style="width: 50%;">Availability</th> </tr> </thead> <tbody> <tr> <td>Normal Mode On, Idle Mode Off, Sleep Out</td> <td style="text-align: center;">Yes</td> </tr> <tr> <td>Normal Mode On, Idle Mode On, Sleep Out</td> <td style="text-align: center;">Yes</td> </tr> <tr> <td>Partial Mode On, Idle Mode Off, Sleep Out</td> <td style="text-align: center;">Yes</td> </tr> <tr> <td>Partial Mode On, Idle Mode On, Sleep Out</td> <td style="text-align: center;">Yes</td> </tr> <tr> <td style="text-align: center;">Sleep In</td> <td style="text-align: center;">Yes</td> </tr> </tbody> </table>													Status	Availability	Normal Mode On, Idle Mode Off, Sleep Out	Yes	Normal Mode On, Idle Mode On, Sleep Out	Yes	Partial Mode On, Idle Mode Off, Sleep Out	Yes	Partial Mode On, Idle Mode On, Sleep Out	Yes	Sleep In	Yes
Status	Availability																								
Normal Mode On, Idle Mode Off, Sleep Out	Yes																								
Normal Mode On, Idle Mode On, Sleep Out	Yes																								
Partial Mode On, Idle Mode Off, Sleep Out	Yes																								
Partial Mode On, Idle Mode On, Sleep Out	Yes																								
Sleep In	Yes																								
Default	<table border="1" style="width: 100%; border-collapse: collapse;"> <thead> <tr> <th style="width: 50%;">Status</th> <th style="width: 50%;">Default Value</th> </tr> </thead> <tbody> <tr> <td>Power On Sequence</td> <td>Display inversion off</td> </tr> <tr> <td>S/W Reset</td> <td>Display inversion off</td> </tr> <tr> <td>H/W Reset</td> <td>Display inversion off</td> </tr> </tbody> </table>													Status	Default Value	Power On Sequence	Display inversion off	S/W Reset	Display inversion off	H/W Reset	Display inversion off				
Status	Default Value																								
Power On Sequence	Display inversion off																								
S/W Reset	Display inversion off																								
H/W Reset	Display inversion off																								

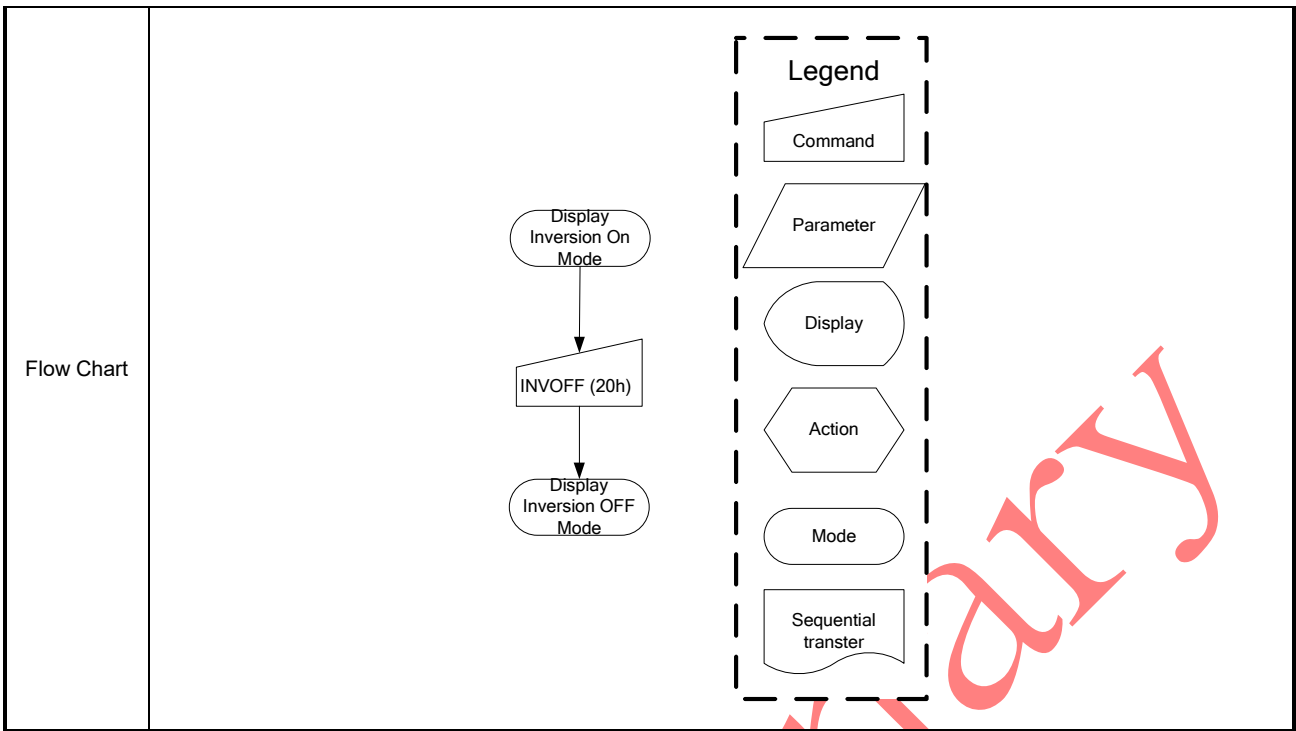



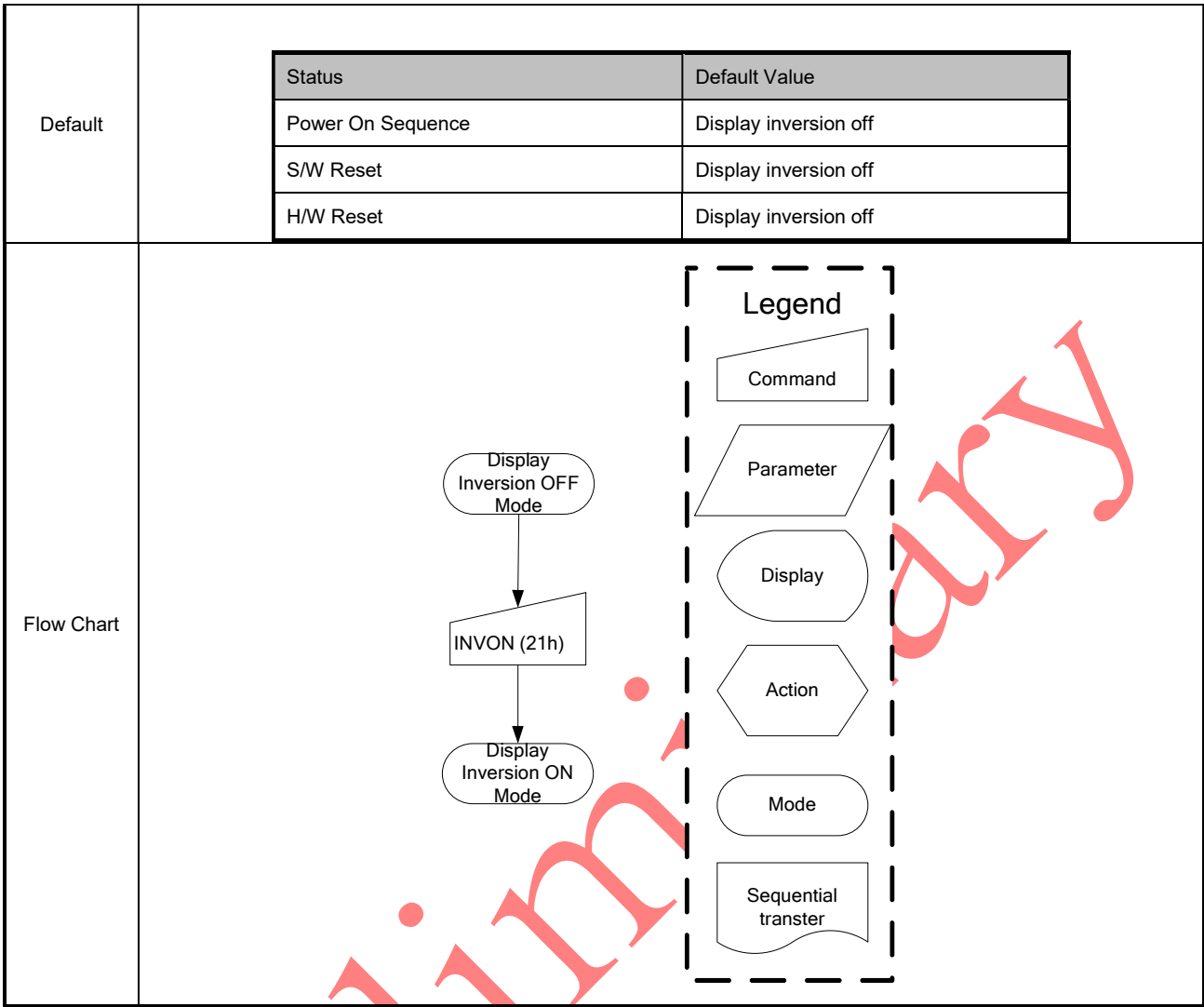

● **INVON (21h): Display Inversion On**

21H	INVON (Display Inversion On)												HEX												
Inst / Para	D/CX	WRX	RDX	D17-8	D7	D6	D5	D4	D3	D2	D1	D0	HEX												
INVON	0	↑	1	-	0	0	1	0	0	0	0	1	(21h)												
parameter	No Parameter																								
Description	<p>-This command is used to recover from display inversion mode.</p> <p>“-“ Don't care</p> <p>(Example)</p> <p>Top-Left (0,0)</p>																								
Restriction	This command has no effect when module is already in inversion on mode.																								
Register availability	<table border="1"> <thead> <tr> <th>Status</th> <th>Availability</th> </tr> </thead> <tbody> <tr> <td>Normal Mode On, Idle Mode Off, Sleep Out</td> <td>Yes</td> </tr> <tr> <td>Normal Mode On, Idle Mode On, Sleep Out</td> <td>Yes</td> </tr> <tr> <td>Partial Mode On, Idle Mode Off, Sleep Out</td> <td>Yes</td> </tr> <tr> <td>Partial Mode On, Idle Mode On, Sleep Out</td> <td>Yes</td> </tr> <tr> <td>Sleep In</td> <td>Yes</td> </tr> </tbody> </table>													Status	Availability	Normal Mode On, Idle Mode Off, Sleep Out	Yes	Normal Mode On, Idle Mode On, Sleep Out	Yes	Partial Mode On, Idle Mode Off, Sleep Out	Yes	Partial Mode On, Idle Mode On, Sleep Out	Yes	Sleep In	Yes
Status	Availability																								
Normal Mode On, Idle Mode Off, Sleep Out	Yes																								
Normal Mode On, Idle Mode On, Sleep Out	Yes																								
Partial Mode On, Idle Mode Off, Sleep Out	Yes																								
Partial Mode On, Idle Mode On, Sleep Out	Yes																								
Sleep In	Yes																								

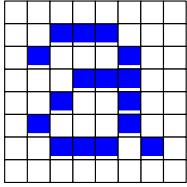
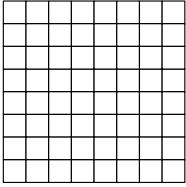
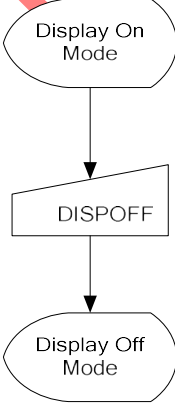
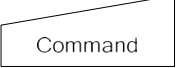

● **DISPOFF (28h): Display Off**

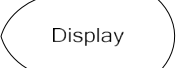
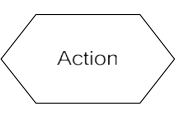
28H	DISPOFF (Display Off)												
Inst / Para	D/CX	WRX	RDX	D17-8	D7	D6	D5	D4	D3	D2	D1	D0	HEX
DISPOFF	0	↑	1	-	0	0	1	0	1	0	0	0	(28h)
parameter	No Parameter												
Description	<ul style="list-style-type: none"> - This command is used to enter into DISPLAY OFF mode. In this mode, the output from Frame Memory is disabled and blank page inserted. - This command makes no change of contents of frame memory. - This command does not change any other status. - There will be no abnormal visible effect on the display. - Exit from this command by Display On (29h) 												

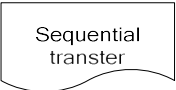
	<p style="text-align: center;">(Example)</p> <div style="display: flex; justify-content: space-around; align-items: center;"> <div style="text-align: center;"> <p>Memory</p>  </div> <div style="font-size: 2em;">→</div> <div style="text-align: center;"> <p>Display</p>  </div> </div>												
Restriction	This command has no effect when module is already in display off mode.												
Register availability	<table border="1" style="width: 100%; border-collapse: collapse; text-align: center;"> <thead> <tr style="background-color: #cccccc;"> <th>Status</th> <th>Availability</th> </tr> </thead> <tbody> <tr> <td>Normal Mode On, Idle Mode Off, Sleep Out</td> <td>Yes</td> </tr> <tr> <td>Normal Mode On, Idle Mode On, Sleep Out</td> <td>Yes</td> </tr> <tr> <td>Partial Mode On, Idle Mode Off, Sleep Out</td> <td>Yes</td> </tr> <tr> <td>Partial Mode On, Idle Mode On, Sleep Out</td> <td>Yes</td> </tr> <tr> <td>Sleep In</td> <td>Yes</td> </tr> </tbody> </table>	Status	Availability	Normal Mode On, Idle Mode Off, Sleep Out	Yes	Normal Mode On, Idle Mode On, Sleep Out	Yes	Partial Mode On, Idle Mode Off, Sleep Out	Yes	Partial Mode On, Idle Mode On, Sleep Out	Yes	Sleep In	Yes
Status	Availability												
Normal Mode On, Idle Mode Off, Sleep Out	Yes												
Normal Mode On, Idle Mode On, Sleep Out	Yes												
Partial Mode On, Idle Mode Off, Sleep Out	Yes												
Partial Mode On, Idle Mode On, Sleep Out	Yes												
Sleep In	Yes												
Default	<table border="1" style="width: 100%; border-collapse: collapse; text-align: center;"> <thead> <tr style="background-color: #cccccc;"> <th>Status</th> <th>Default Value</th> </tr> </thead> <tbody> <tr> <td>Power On Sequence</td> <td>Display off</td> </tr> <tr> <td>S/W Reset</td> <td>Display off</td> </tr> <tr> <td>H/W Reset</td> <td>Display off</td> </tr> </tbody> </table>	Status	Default Value	Power On Sequence	Display off	S/W Reset	Display off	H/W Reset	Display off				
Status	Default Value												
Power On Sequence	Display off												
S/W Reset	Display off												
H/W Reset	Display off												
Flow Chart	<div style="display: flex; align-items: center;"> <div style="flex: 1;">  <pre> graph TD A([Display On Mode]) --> B[/DISPOFF/] B --> C([Display Off Mode]) </pre> </div> <div style="flex: 1; border: 1px dashed black; padding: 5px;"> <p style="text-align: center;">Legend</p> <ul style="list-style-type: none"> <li style="margin-bottom: 5px;">  Command <li style="margin-bottom: 5px;">  Parameter <li style="margin-bottom: 5px;">  Display <li style="margin-bottom: 5px;">  Action <li style="margin-bottom: 5px;">  Mode <li style="margin-bottom: 5px;">  Sequential transfer </div> </div>												

● DISPON (29h): Display On

29H	DISPON (Display On)												HEX												
Inst / Para	D/CX	WRX	RDX	D17-8	D7	D6	D5	D4	D3	D2	D1	D0	HEX												
DISPO N	0	↑	1	-	0	0	1	0	1	0	0	1	(29h)												
parameter	No Parameter																								
Description	<p>- This command is used to recover from DISPLAY OFF mode.</p> <p>- Output from the Frame Memory is enabled.</p> <p>- This command makes no change of contents of frame memory.</p> <p>- This command does not change any other status.</p> <div style="text-align: center;"> <p>(Example)</p> </div>																								
Restriction	This command has no effect when module is already in display on mode.																								
Register availability	<table border="1" style="width: 100%; border-collapse: collapse;"> <thead> <tr> <th style="width: 50%;">Status</th> <th style="width: 50%;">Availability</th> </tr> </thead> <tbody> <tr> <td>Normal Mode On, Idle Mode Off, Sleep Out</td> <td>Yes</td> </tr> <tr> <td>Normal Mode On, Idle Mode On, Sleep Out</td> <td>Yes</td> </tr> <tr> <td>Partial Mode On, Idle Mode Off, Sleep Out</td> <td>Yes</td> </tr> <tr> <td>Partial Mode On, Idle Mode On, Sleep Out</td> <td>Yes</td> </tr> <tr> <td>Sleep In</td> <td>Yes</td> </tr> </tbody> </table>													Status	Availability	Normal Mode On, Idle Mode Off, Sleep Out	Yes	Normal Mode On, Idle Mode On, Sleep Out	Yes	Partial Mode On, Idle Mode Off, Sleep Out	Yes	Partial Mode On, Idle Mode On, Sleep Out	Yes	Sleep In	Yes
Status	Availability																								
Normal Mode On, Idle Mode Off, Sleep Out	Yes																								
Normal Mode On, Idle Mode On, Sleep Out	Yes																								
Partial Mode On, Idle Mode Off, Sleep Out	Yes																								
Partial Mode On, Idle Mode On, Sleep Out	Yes																								
Sleep In	Yes																								
Default	<table border="1" style="width: 100%; border-collapse: collapse;"> <thead> <tr> <th style="width: 50%;">Status</th> <th style="width: 50%;">Default Value</th> </tr> </thead> <tbody> <tr> <td>Power On Sequence</td> <td>Display off</td> </tr> <tr> <td>S/W Reset</td> <td>Display off</td> </tr> <tr> <td>H/W Reset</td> <td>Display off</td> </tr> </tbody> </table>													Status	Default Value	Power On Sequence	Display off	S/W Reset	Display off	H/W Reset	Display off				
Status	Default Value																								
Power On Sequence	Display off																								
S/W Reset	Display off																								
H/W Reset	Display off																								

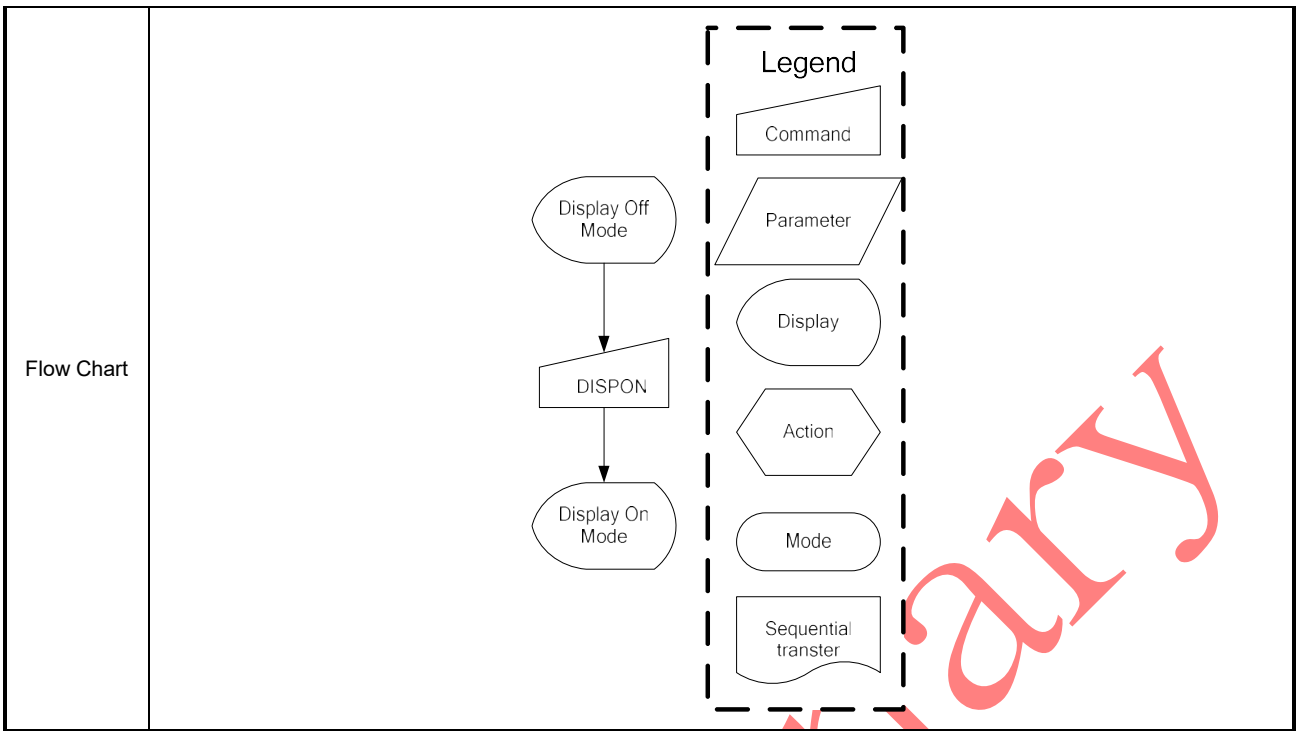

● IDMOFF (38h): Idle Mode Off

38H	IDMOFF (Idle Mode Off)												HEX												
Inst / Para	D/CX	WRX	RDX	D17-8	D7	D6	D5	D4	D3	D2	D1	D0	HEX												
IDMOFF	0	↑	1	-	0	0	1	1	1	0	0	0	(38h)												
parameter	No Parameter																								
Description	<p>-This command is used to recover from Idle mode on.</p> <p>-In the idle off mode,</p> <ol style="list-style-type: none"> LCD can display 65k, 262k or 16M colors. Normal frame frequency is applied. 																								
Restriction	This command has no effect when module is already in idle off mode																								
Register availability	<table border="1"> <thead> <tr> <th>Status</th> <th>Availability</th> </tr> </thead> <tbody> <tr> <td>Normal Mode On, Idle Mode Off, Sleep Out</td> <td>Yes</td> </tr> <tr> <td>Normal Mode On, Idle Mode On, Sleep Out</td> <td>Yes</td> </tr> <tr> <td>Partial Mode On, Idle Mode Off, Sleep Out</td> <td>Yes</td> </tr> <tr> <td>Partial Mode On, Idle Mode On, Sleep Out</td> <td>Yes</td> </tr> <tr> <td>Sleep In</td> <td>Yes</td> </tr> </tbody> </table>													Status	Availability	Normal Mode On, Idle Mode Off, Sleep Out	Yes	Normal Mode On, Idle Mode On, Sleep Out	Yes	Partial Mode On, Idle Mode Off, Sleep Out	Yes	Partial Mode On, Idle Mode On, Sleep Out	Yes	Sleep In	Yes
Status	Availability																								
Normal Mode On, Idle Mode Off, Sleep Out	Yes																								
Normal Mode On, Idle Mode On, Sleep Out	Yes																								
Partial Mode On, Idle Mode Off, Sleep Out	Yes																								
Partial Mode On, Idle Mode On, Sleep Out	Yes																								
Sleep In	Yes																								

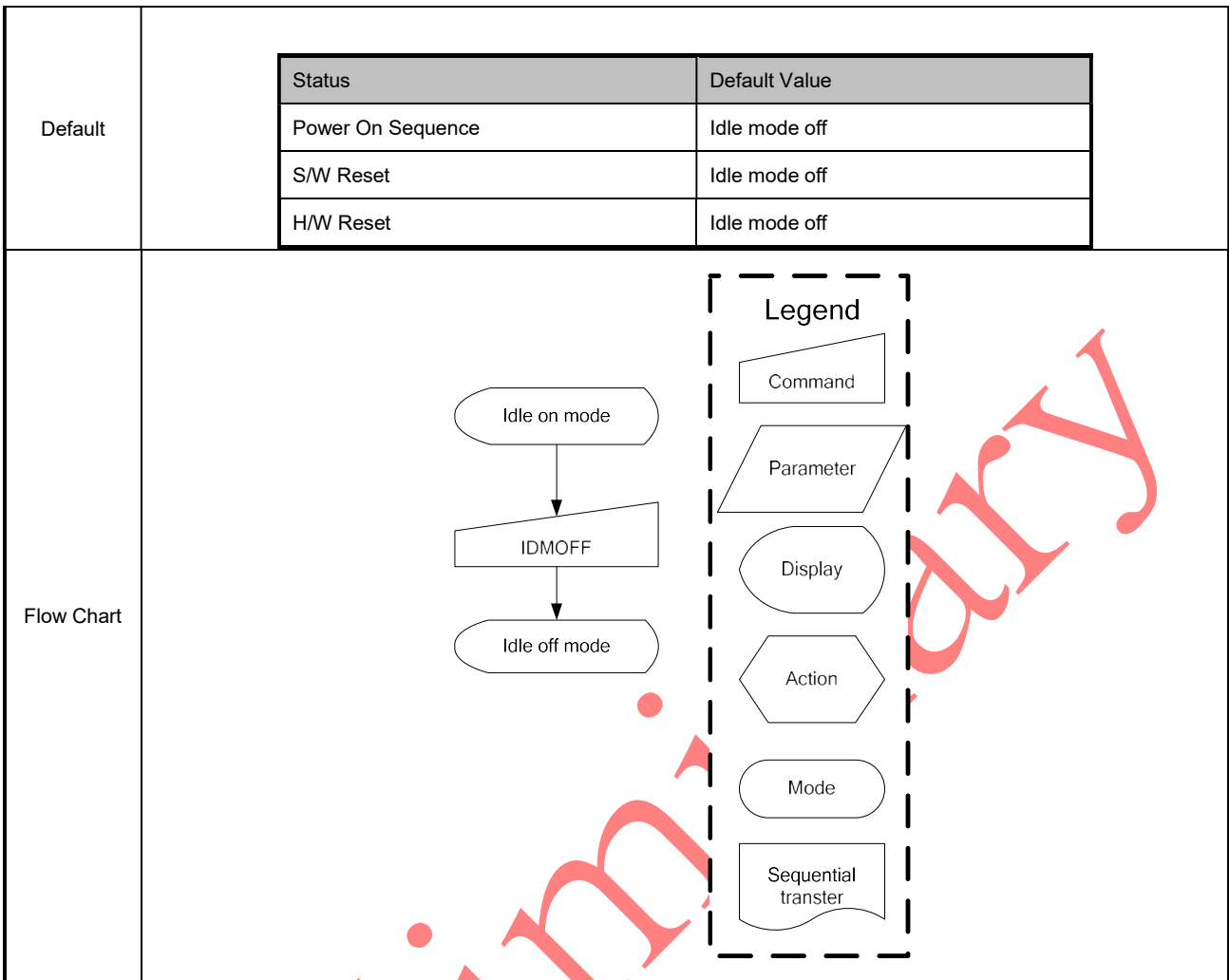

● IDMON (39h): Idle mode on

39H	IDMON (Idle Mode On)												
Inst / Para	D/CX	WRX	RDX	D17-8	D7	D6	D5	D4	D3	D2	D1	D0	HEX
IDMON	0	↑	1	-	0	0	1	1	1	0	0	1	(39h)
parameter	No Parameter												
Description	<p>-This command is used to enter into Idle mode on.</p> <p>-There will be no abnormal visible effect on the display mode change transition.</p> <p>-In the idle on mode,</p> <ol style="list-style-type: none"> 1. Color expression is reduced. The primary and the secondary colors using MSB of each R,G and B in the Frame Memory, 8 color depth data is displayed. 2. 8-Color mode frame frequency is applied. 3. Exit from IDMON by Idle Mode Off (38h) command 												

Top-Left (0,0)

(Example) Memory

Display

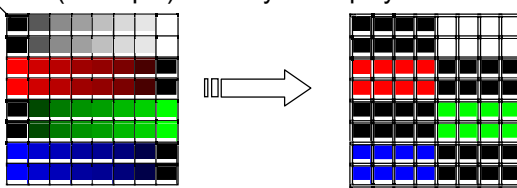

Color	R5 R4 R3 R2 R1 R0	G5 G4 G3 G2 G1 G0	B5 B4 B3 B4 B1 B0
Black	0xxxxx	0xxxxx	0xxxxx
Blue	0xxxxx	0xxxxx	1xxxxx
Red	1xxxxx	0xxxxx	0xxxxx
Magenta	1xxxxx	0xxxxx	1xxxxx
Green	0xxxxx	1xxxxx	0xxxxx
Cyan	0xxxxx	1xxxxx	1xxxxx
Yellow	1xxxxx	1xxxxx	0xxxxx
White	1xxxxx	1xxxxx	1xxxxx

Restriction

This command has no effect when module is already in idle off mode

Register availability

Status	Availability
Normal Mode On, Idle Mode Off, Sleep Out	Yes
Normal Mode On, Idle Mode On, Sleep Out	Yes
Partial Mode On, Idle Mode Off, Sleep Out	Yes
Partial Mode On, Idle Mode On, Sleep Out	Yes
Sleep In	Yes

Default

Status	Default Value
Power On Sequence	Idle mode off
S/W Reset	Idle mode off
H/W Reset	Idle mode off

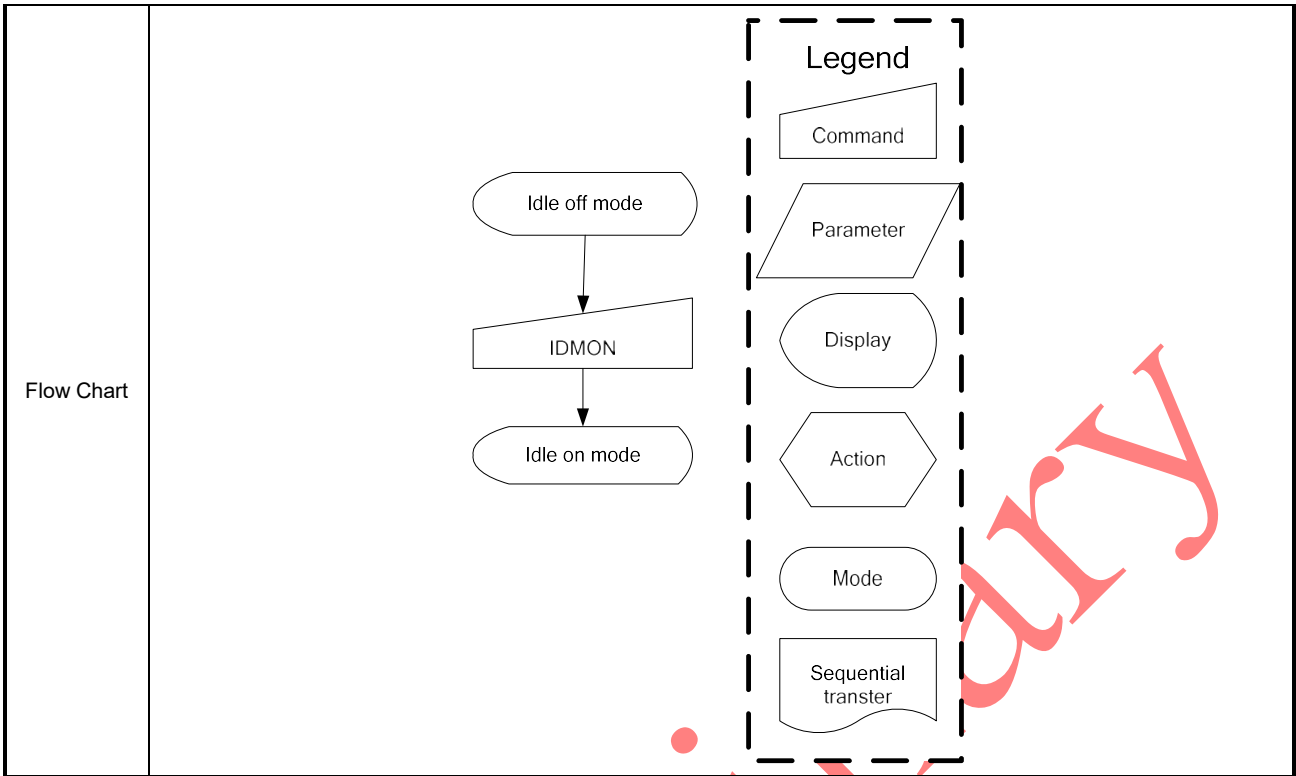

● MADCTL (36h): Memory Data Access Control

36H	MADCTL (Memory Data Access Control)												HEX
Inst / Para	D/CX	WRX	RDX	D17-8	D7	D6	D5	D4	D3	D2	D1	D0	HEX
MADCTL	0	↑	1	-	0	0	1	1	0	1	1	0	(36h)
parameter	1	↑	1	-	-	-	-	ML	BGR	MH	-	-	(00h)
-This command defines read/ write scanning direction of frame memory.													
Description	Bit	NAME		DESCRIPTION									
	ML	Vertical Refresh Order		LCD vertical refresh direction control '0' = LCD vertical refresh Top to Bottom '1' = LCD vertical refresh Bottom to Top									
	BGR	RGB-BGR ORDER		Color selector switch control '0' =RGB color filter panel, '1' =BGR color filter panel									
	MH	Horizontal Refresh Order		Horizontal direction '0' = Left to Right '1' = Right to Left									
-Bit Assignment													

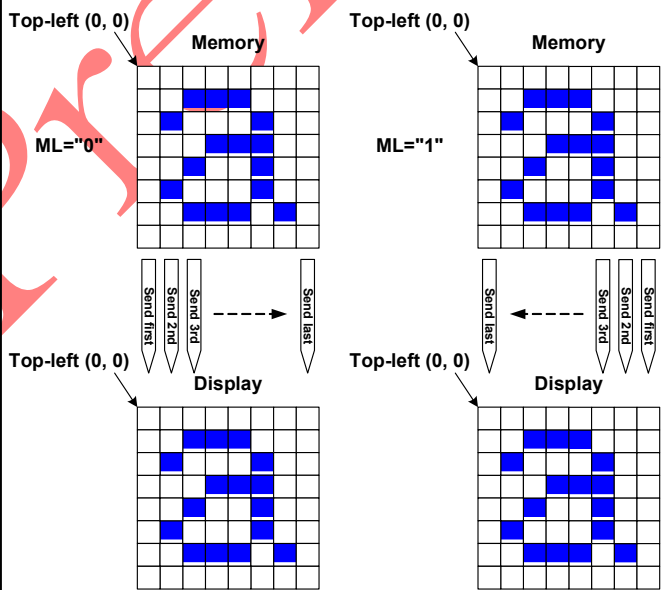
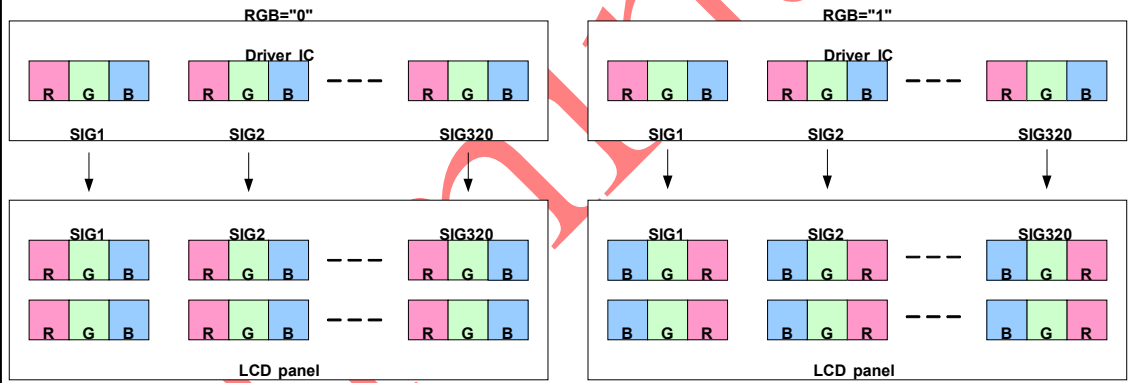
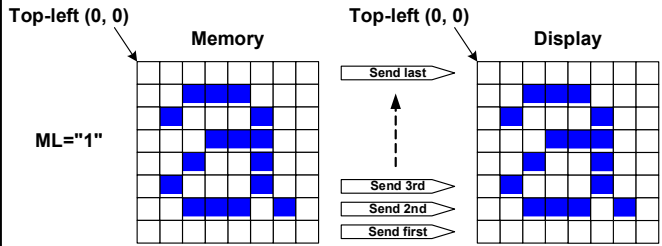
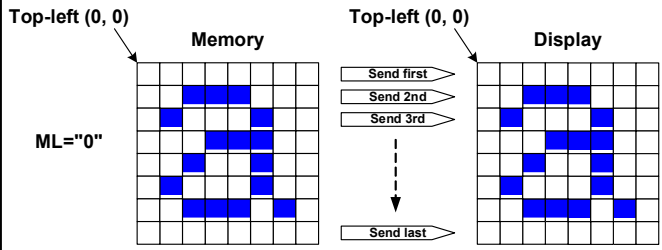

Register

availability	<table border="1"> <thead> <tr> <th>Status</th> <th>Availability</th> </tr> </thead> <tbody> <tr> <td>Normal Mode On, Idle Mode Off, Sleep Out</td> <td>Yes</td> </tr> <tr> <td>Normal Mode On, Idle Mode On, Sleep Out</td> <td>Yes</td> </tr> <tr> <td>Partial Mode On, Idle Mode Off, Sleep Out</td> <td>Yes</td> </tr> <tr> <td>Partial Mode On, Idle Mode On, Sleep Out</td> <td>Yes</td> </tr> <tr> <td>Sleep In</td> <td>Yes</td> </tr> </tbody> </table>		Status	Availability	Normal Mode On, Idle Mode Off, Sleep Out	Yes	Normal Mode On, Idle Mode On, Sleep Out	Yes	Partial Mode On, Idle Mode Off, Sleep Out	Yes	Partial Mode On, Idle Mode On, Sleep Out	Yes	Sleep In	Yes
	Status	Availability												
	Normal Mode On, Idle Mode Off, Sleep Out	Yes												
	Normal Mode On, Idle Mode On, Sleep Out	Yes												
	Partial Mode On, Idle Mode Off, Sleep Out	Yes												
	Partial Mode On, Idle Mode On, Sleep Out	Yes												
Sleep In	Yes													
Default	<table border="1"> <thead> <tr> <th>Status</th> <th>Default Value</th> </tr> </thead> <tbody> <tr> <td>Power On Sequence</td> <td>0000h</td> </tr> <tr> <td>S/W Reset</td> <td>No change</td> </tr> <tr> <td>H/W Reset</td> <td>0000h</td> </tr> </tbody> </table>		Status	Default Value	Power On Sequence	0000h	S/W Reset	No change	H/W Reset	0000h				
	Status	Default Value												
	Power On Sequence	0000h												
	S/W Reset	No change												
H/W Reset	0000h													
Flow Chart	<pre> graph TD MADCTL[MADCTL] --> Param[/1st parameter B[7:0]/] </pre>													
	<p>Legend</p> <ul style="list-style-type: none"> Command Parameter Display Action Mode Sequential transfer 													

● MOLMOD (3Ah): Interface Pixel Format

3AH	COLMOD (Interface Pixel Format)																								
Inst / Para	D/CX	WRX	RDX	D17-8	D7	D6	D5	D4	D3	D2	D1	D0	HEX												
COLMOD	0	↑	1	-	0	0	1	1	1	0	1	0	(3Ah)												
Parameter	1	↑	1	-	-	-	-	-	-	DBI.2-0		(06h)													
Description	This command is used to define the format of RGB picture data, which is to be transferred via the DBI.2-0: Display pixel input format for 1bpp mode. "101": 565 color; "110": 666 color; "111": 888 color.																								
Register availability	<table border="1"> <thead> <tr> <th>Status</th> <th>Availability</th> </tr> </thead> <tbody> <tr> <td>Normal Mode On, Idle Mode Off, Sleep Out</td> <td>Yes</td> </tr> <tr> <td>Normal Mode On, Idle Mode On, Sleep Out</td> <td>Yes</td> </tr> <tr> <td>Partial Mode On, Idle Mode Off, Sleep Out</td> <td>Yes</td> </tr> <tr> <td>Partial Mode On, Idle Mode On, Sleep Out</td> <td>Yes</td> </tr> <tr> <td>Sleep In</td> <td>Yes</td> </tr> </tbody> </table>													Status	Availability	Normal Mode On, Idle Mode Off, Sleep Out	Yes	Normal Mode On, Idle Mode On, Sleep Out	Yes	Partial Mode On, Idle Mode Off, Sleep Out	Yes	Partial Mode On, Idle Mode On, Sleep Out	Yes	Sleep In	Yes
Status	Availability																								
Normal Mode On, Idle Mode Off, Sleep Out	Yes																								
Normal Mode On, Idle Mode On, Sleep Out	Yes																								
Partial Mode On, Idle Mode Off, Sleep Out	Yes																								
Partial Mode On, Idle Mode On, Sleep Out	Yes																								
Sleep In	Yes																								
Default	<table border="1"> <thead> <tr> <th>Status</th> <th>Default Value</th> </tr> </thead> <tbody> <tr> <td>Power On Sequence</td> <td>18bit/pixel</td> </tr> <tr> <td>S/W Reset</td> <td>No change</td> </tr> <tr> <td>H/W Reset</td> <td>18bit/pixel</td> </tr> </tbody> </table>													Status	Default Value	Power On Sequence	18bit/pixel	S/W Reset	No change	H/W Reset	18bit/pixel				
Status	Default Value																								
Power On Sequence	18bit/pixel																								
S/W Reset	No change																								
H/W Reset	18bit/pixel																								
Flow Chart	<pre> graph TD A([16 bit Pixel Format]) --> B[/COLMOD/] B --> C[/110/] C --> D([18 bit Pixel Format]) </pre> <p>Legend</p> <ul style="list-style-type: none"> Command: Trapezoid Parameter: Parallelogram Display: Oval Action: Hexagon Mode: Rounded rectangle Sequential transfer: Wavy rectangle 																								

● RAMWR (2Ch): Memory Write

2CH	RAMWR (Memory Write)																								
Inst / Para	D/CX	WRX	RDX	D17-8	D7	D6	D5	D4	D3	D2	D1	D0	HEX												
RAMWR	0	↑	1	-	0	0	1	0	1	1	0	0	(2Ch)												
1 st parameter	1	↑	1	-	D1.7-0							-													
...	1	↑	1	-	Dx.7-0							-													
N parameter	1	↑	1	-	Dn.7-0							-													
Description	<p>-This command is used to transfer data from MCU to frame memory.</p> <p>-When this command is accepted, the column register and the page register are reset to the start column/start page positions.</p> <p>-The start column/start page positions are different in accordance with MADCTL setting.</p> <p>-Sending any other command can stop frame write.</p>																								
Restriction	In all color modes, there is no restriction on length of parameters.																								
Register availability	<table border="1"> <thead> <tr> <th>Status</th> <th>Availability</th> </tr> </thead> <tbody> <tr> <td>Normal Mode On, Idle Mode Off, Sleep Out</td> <td>Yes</td> </tr> <tr> <td>Normal Mode On, Idle Mode On, Sleep Out</td> <td>Yes</td> </tr> <tr> <td>Partial Mode On, Idle Mode Off, Sleep Out</td> <td>Yes</td> </tr> <tr> <td>Partial Mode On, Idle Mode On, Sleep Out</td> <td>Yes</td> </tr> <tr> <td>Sleep In</td> <td>Yes</td> </tr> </tbody> </table>													Status	Availability	Normal Mode On, Idle Mode Off, Sleep Out	Yes	Normal Mode On, Idle Mode On, Sleep Out	Yes	Partial Mode On, Idle Mode Off, Sleep Out	Yes	Partial Mode On, Idle Mode On, Sleep Out	Yes	Sleep In	Yes
Status	Availability																								
Normal Mode On, Idle Mode Off, Sleep Out	Yes																								
Normal Mode On, Idle Mode On, Sleep Out	Yes																								
Partial Mode On, Idle Mode Off, Sleep Out	Yes																								
Partial Mode On, Idle Mode On, Sleep Out	Yes																								
Sleep In	Yes																								
Default	<table border="1"> <thead> <tr> <th>Status</th> <th>Default Value</th> </tr> </thead> <tbody> <tr> <td>Power On Sequence</td> <td>Contents of memory is set randomly</td> </tr> <tr> <td>S/W Reset</td> <td>Contents of memory is not cleared</td> </tr> <tr> <td>H/W Reset</td> <td>Contents of memory is not cleared</td> </tr> </tbody> </table>													Status	Default Value	Power On Sequence	Contents of memory is set randomly	S/W Reset	Contents of memory is not cleared	H/W Reset	Contents of memory is not cleared				
Status	Default Value																								
Power On Sequence	Contents of memory is set randomly																								
S/W Reset	Contents of memory is not cleared																								
H/W Reset	Contents of memory is not cleared																								

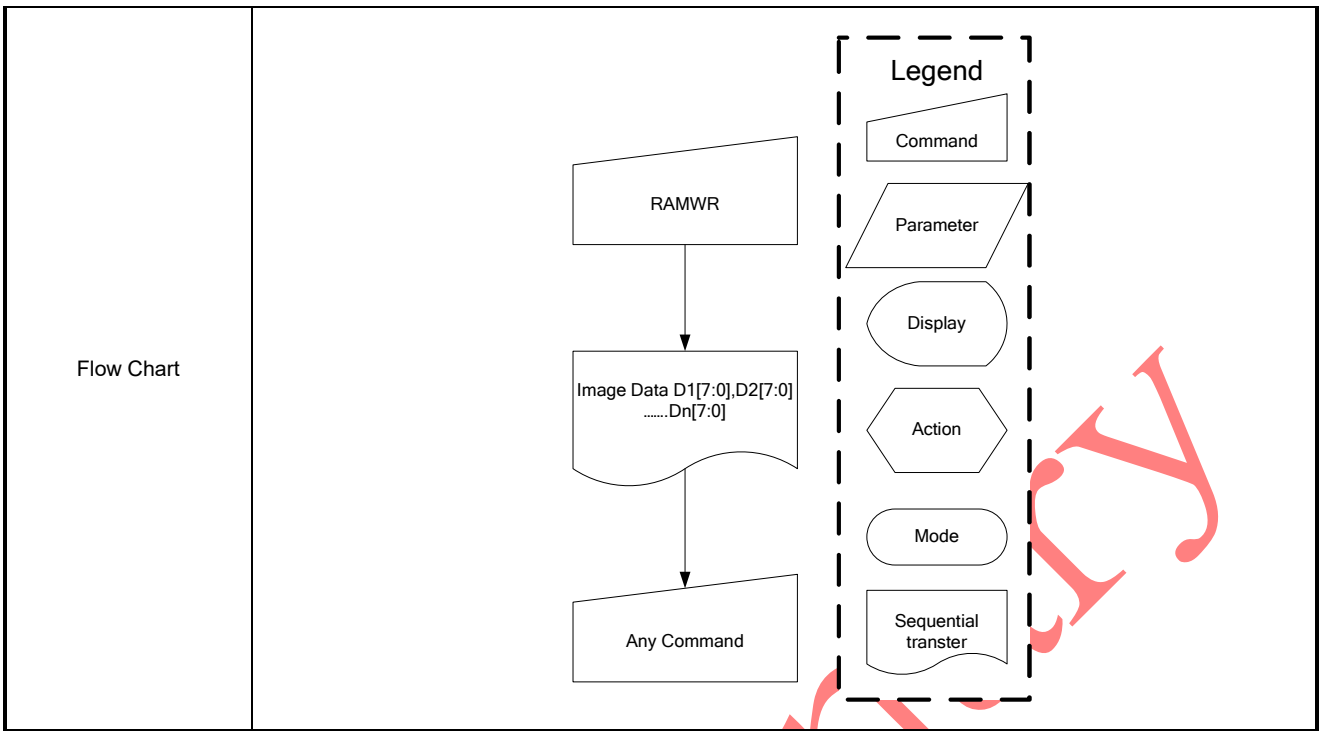





● WRMEMC (3Ch): Write Memory Continue

3CH	WRMEMC (Write Memory Continue)												
Inst / Para	D/CX	WRX	RDX	D17-8	D7	D6	D5	D4	D3	D2	D1	D0	HEX
WRMEMC	0	↑	1	-	0	0	1	0	1	1	0	0	(2Ch)
1 ST parameter	1	↑	1	-	D1.7-0							-	
⋮	1	↑	1	-	Dx.7-0							-	
N th parameter	1	↑	1	-	Dn.7-0							-	
Description	<p>-This command transfers image data from the host processor to the display module's frame memory continuing from the pixel location following the previous write memory continue or memory write command.:</p> <p>Data is written continuing from the pixel location after the write range of the previous memory write or write memory continue. The column register is then incremented and pixels are written to the frame memory until the column register equals the end column (XE) value. The column register is then reset to XS and the page register is incremented. Pixels are written to the frame memory until the page register equals the end page (YE) value and the column register equals the XE value, or the host processor sends another command. If the number of pixels exceeds (XE-XS+1)*(YE-YS+1) the extra pixels are ignored.</p>												

	<table border="1"> <thead> <tr> <th>Condition</th> <th>Column</th> <th>Page</th> </tr> </thead> <tbody> <tr> <td>Command 2C is accepted</td> <td>Return to "Start Column"</td> <td>Return to "Start Page"</td> </tr> <tr> <td>Read/Write RAM action</td> <td>Increment by 1</td> <td>No change</td> </tr> <tr> <td>Column value is large than "End Column"</td> <td>Return to "Start Column"</td> <td>Increment by 1</td> </tr> <tr> <td>Page value is large than "End Page"</td> <td>Return to "Start Column"</td> <td>Return to "Start Page"</td> </tr> </tbody> </table>	Condition	Column	Page	Command 2C is accepted	Return to "Start Column"	Return to "Start Page"	Read/Write RAM action	Increment by 1	No change	Column value is large than "End Column"	Return to "Start Column"	Increment by 1	Page value is large than "End Page"	Return to "Start Column"	Return to "Start Page"
Condition	Column	Page														
Command 2C is accepted	Return to "Start Column"	Return to "Start Page"														
Read/Write RAM action	Increment by 1	No change														
Column value is large than "End Column"	Return to "Start Column"	Increment by 1														
Page value is large than "End Page"	Return to "Start Column"	Return to "Start Page"														
Restriction	<i>A memory write should follow a column address set or page address set to define the write address. Otherwise, data written with write memory continue is written to undefined addresses.</i>															
Register availability	<table border="1"> <thead> <tr> <th>Status</th> <th>Availability</th> </tr> </thead> <tbody> <tr> <td>Normal Mode On, Idle Mode Off, Sleep Out</td> <td>Yes</td> </tr> <tr> <td>Normal Mode On, Idle Mode On, Sleep Out</td> <td>Yes</td> </tr> <tr> <td>Partial Mode On, Idle Mode Off, Sleep Out</td> <td>Yes</td> </tr> <tr> <td>Partial Mode On, Idle Mode On, Sleep Out</td> <td>Yes</td> </tr> <tr> <td>Sleep In</td> <td>Yes</td> </tr> </tbody> </table>	Status	Availability	Normal Mode On, Idle Mode Off, Sleep Out	Yes	Normal Mode On, Idle Mode On, Sleep Out	Yes	Partial Mode On, Idle Mode Off, Sleep Out	Yes	Partial Mode On, Idle Mode On, Sleep Out	Yes	Sleep In	Yes			
Status	Availability															
Normal Mode On, Idle Mode Off, Sleep Out	Yes															
Normal Mode On, Idle Mode On, Sleep Out	Yes															
Partial Mode On, Idle Mode Off, Sleep Out	Yes															
Partial Mode On, Idle Mode On, Sleep Out	Yes															
Sleep In	Yes															
Default	<table border="1"> <thead> <tr> <th>Status</th> <th>Default Value</th> </tr> </thead> <tbody> <tr> <td>Power On Sequence</td> <td>Contents of memory is set randomly</td> </tr> <tr> <td>S/W Reset</td> <td>Contents of memory is not cleared</td> </tr> <tr> <td>H/W Reset</td> <td>Contents of memory is not cleared</td> </tr> </tbody> </table>	Status	Default Value	Power On Sequence	Contents of memory is set randomly	S/W Reset	Contents of memory is not cleared	H/W Reset	Contents of memory is not cleared							
Status	Default Value															
Power On Sequence	Contents of memory is set randomly															
S/W Reset	Contents of memory is not cleared															
H/W Reset	Contents of memory is not cleared															
Flow Chart	<pre> graph TD A[WRMEMC] --> B[Image Data D1[17:0], D2[17:0] Dn[17:0]] B --> C[Any Command] </pre> <p>Legend</p> <ul style="list-style-type: none"> Command Parameter Display Action Mode Sequential transfer 															

● TEOFF (34h): Tearing Effect Line OFF

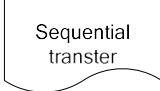
34H	TEOFF (Tearing Effect Line OFF)												HEX												
Inst / Para	D/CX	WRX	RDX	D17-8	D7	D6	D5	D4	D3	D2	D1	D0	HEX												
TEOFF	0	↑	1	-	0	0	1	1	0	1	0	0	(34h)												
parameter	No Parameter																								
Description	-This command is used to turn OFF (Active Low) the Tearing Effect output signal from the TE signal line.																								
Restriction	This command has no effect when tearing effect output is already off..																								
Register availability	<table border="1"> <thead> <tr> <th>Status</th> <th>Availability</th> </tr> </thead> <tbody> <tr> <td>Normal Mode On, Idle Mode Off, Sleep Out</td> <td>Yes</td> </tr> <tr> <td>Normal Mode On, Idle Mode On, Sleep Out</td> <td>Yes</td> </tr> <tr> <td>Partial Mode On, Idle Mode Off, Sleep Out</td> <td>Yes</td> </tr> <tr> <td>Partial Mode On, Idle Mode On, Sleep Out</td> <td>Yes</td> </tr> <tr> <td>Sleep In</td> <td>Yes</td> </tr> </tbody> </table>													Status	Availability	Normal Mode On, Idle Mode Off, Sleep Out	Yes	Normal Mode On, Idle Mode On, Sleep Out	Yes	Partial Mode On, Idle Mode Off, Sleep Out	Yes	Partial Mode On, Idle Mode On, Sleep Out	Yes	Sleep In	Yes
Status	Availability																								
Normal Mode On, Idle Mode Off, Sleep Out	Yes																								
Normal Mode On, Idle Mode On, Sleep Out	Yes																								
Partial Mode On, Idle Mode Off, Sleep Out	Yes																								
Partial Mode On, Idle Mode On, Sleep Out	Yes																								
Sleep In	Yes																								
Default	<table border="1"> <thead> <tr> <th>Status</th> <th>Default Value</th> </tr> </thead> <tbody> <tr> <td>Power On Sequence</td> <td>Off</td> </tr> <tr> <td>S/W Reset</td> <td>Off</td> </tr> <tr> <td>H/W Reset</td> <td>Off</td> </tr> </tbody> </table>													Status	Default Value	Power On Sequence	Off	S/W Reset	Off	H/W Reset	Off				
Status	Default Value																								
Power On Sequence	Off																								
S/W Reset	Off																								
H/W Reset	Off																								
Flow Chart	<div style="border: 1px dashed black; padding: 10px;"> <p>Legend</p> <ul style="list-style-type: none">  Command  Parameter  Display  Action  Mode  Sequential transfer <pre> graph TD A([TE Line Output ON]) --> B[/TEOFF/] B --> C([TE Line Output OFF]) </pre> </div>																								

● TEON (35h): Tearing Effect Line On

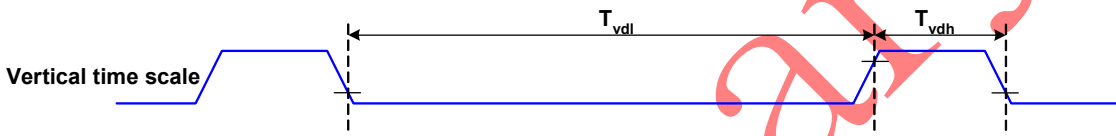
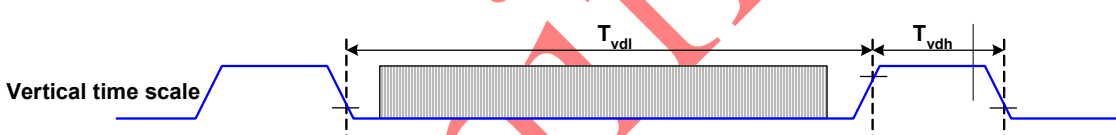
35H	TEON (Tearing Effect Line On)												HEX												
Inst / Para	D/CX	WRX	RDX	D17-8	D7	D6	D5	D4	D3	D2	D1	D0	HEX												
TEON	0	↑	1	-	0	0	1	1	0	1	0	1	(35h)												
parameter	1	↑	1	-	0	0	0	0	0	0	0	TEM													
Description	<p>-This command is used to turn ON the Tearing Effect output signal from the TE signal line.</p> <p>-This output is not affected by changing MADCTL bit ML.</p> <p>-The Tearing Effect Line On has one parameter, which describes the mode of the Tearing Effect Output Line:</p> <p>-When TEM = '0': The Tearing Effect output line consists of V-Blanking information only</p>  <p>-When TEM = '1': The Tearing Effect output Line consists of both V-Blanking and H-Blanking information</p>  <p>Note: During Sleep In Mode with Tearing Effect Line On, Tearing Effect Output pin will be active Low.</p>																								
Restriction	This command has no effect when tearing effect output is already on.																								
Register availability	<table border="1"> <thead> <tr> <th>Status</th> <th>Availability</th> </tr> </thead> <tbody> <tr> <td>Normal Mode On, Idle Mode Off, Sleep Out</td> <td>Yes</td> </tr> <tr> <td>Normal Mode On, Idle Mode On, Sleep Out</td> <td>Yes</td> </tr> <tr> <td>Partial Mode On, Idle Mode Off, Sleep Out</td> <td>Yes</td> </tr> <tr> <td>Partial Mode On, Idle Mode On, Sleep Out</td> <td>Yes</td> </tr> <tr> <td>Sleep In</td> <td>Yes</td> </tr> </tbody> </table>													Status	Availability	Normal Mode On, Idle Mode Off, Sleep Out	Yes	Normal Mode On, Idle Mode On, Sleep Out	Yes	Partial Mode On, Idle Mode Off, Sleep Out	Yes	Partial Mode On, Idle Mode On, Sleep Out	Yes	Sleep In	Yes
Status	Availability																								
Normal Mode On, Idle Mode Off, Sleep Out	Yes																								
Normal Mode On, Idle Mode On, Sleep Out	Yes																								
Partial Mode On, Idle Mode Off, Sleep Out	Yes																								
Partial Mode On, Idle Mode On, Sleep Out	Yes																								
Sleep In	Yes																								
Default	<table border="1"> <thead> <tr> <th>Status</th> <th>Default Value</th> </tr> </thead> <tbody> <tr> <td>Power On Sequence</td> <td>Off</td> </tr> <tr> <td>S/W Reset</td> <td>Off</td> </tr> <tr> <td>H/W Reset</td> <td>Off</td> </tr> </tbody> </table>													Status	Default Value	Power On Sequence	Off	S/W Reset	Off	H/W Reset	Off				
Status	Default Value																								
Power On Sequence	Off																								
S/W Reset	Off																								
H/W Reset	Off																								

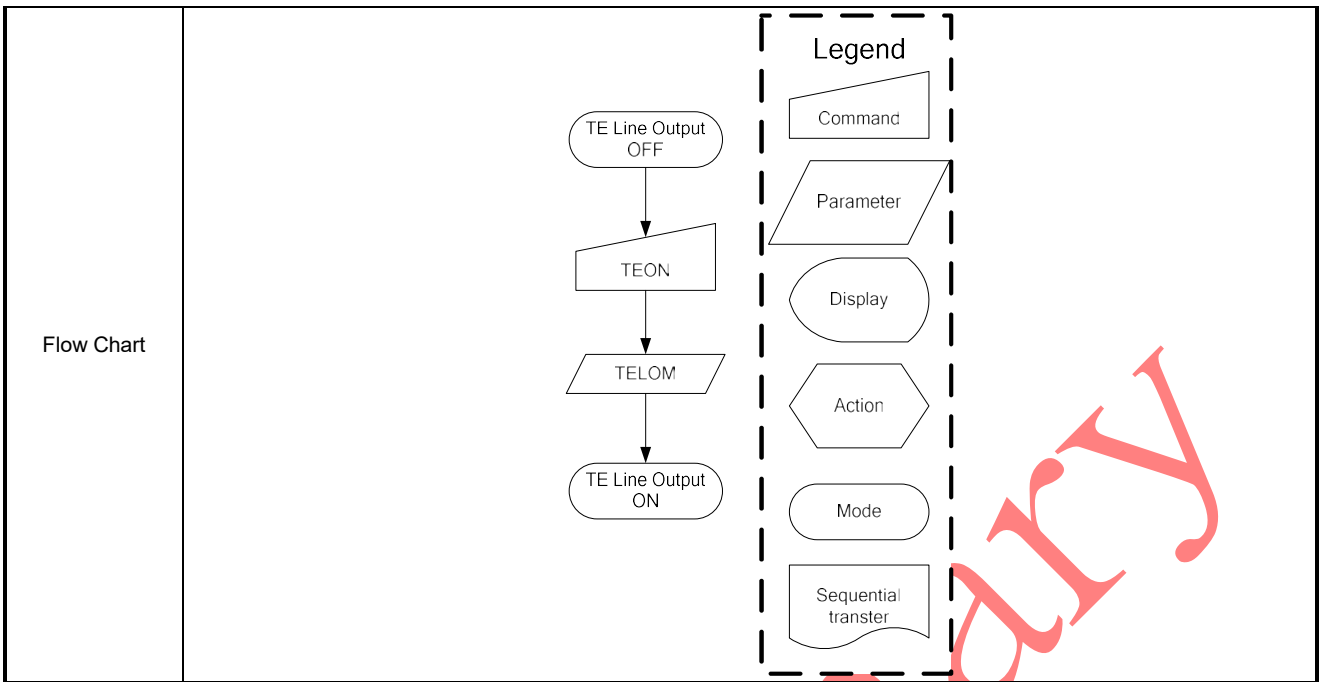

● STE (44h): Write Tear Scanline

44H	STE (Write Tear ScanLine)												HEX
Inst / Para	D/CX	WRX	RDX	D17-8	D7	D6	D5	D4	D3	D2	D1	D0	HEX
STE	0	↑	1	-	0	1	0	0	0	1	0	0	(44h)
1 st parameter	1	↑	1	-	-	-	-	-	-	-	-	N.8	(00h)
2 nd parameter	1	↑	1	-	N.7-0							(00h)	
Description	<p>-This command turns on the display module's Tearing Effect output signal on the TE signal line when the display module reaches line N. The TE signal is not affected by changing MV.</p> <p>-The tearing effect line on has one parameter that describes the tearing effect output line mode.</p> <p>-The tearing effect output line consist of V-blanking information only.</p> <p>Note that set tear scanline with N=0 is equivalent to tearing effect line on with TEM=0.</p> <p>The tearing effect output line shall be active low when the display module is in sleep mode</p>												
Restriction	<p>This command takes affect on the frame following the current frame. Therefore, if the tear effect (TE) output is already on, the TE output shall continue to operate as programmed by the previous tearing effect line on or set tear scanline command until the end of the frame</p>												
Register availability													

	<table border="1"> <thead> <tr> <th>Status</th> <th>Availability</th> </tr> </thead> <tbody> <tr> <td>Normal Mode On, Idle Mode Off, Sleep Out</td> <td>Yes</td> </tr> <tr> <td>Normal Mode On, Idle Mode On, Sleep Out</td> <td>Yes</td> </tr> <tr> <td>Partial Mode On, Idle Mode Off, Sleep Out</td> <td>Yes</td> </tr> <tr> <td>Partial Mode On, Idle Mode On, Sleep Out</td> <td>Yes</td> </tr> <tr> <td>Sleep In</td> <td>Yes</td> </tr> </tbody> </table>	Status	Availability	Normal Mode On, Idle Mode Off, Sleep Out	Yes	Normal Mode On, Idle Mode On, Sleep Out	Yes	Partial Mode On, Idle Mode Off, Sleep Out	Yes	Partial Mode On, Idle Mode On, Sleep Out	Yes	Sleep In	Yes
Status	Availability												
Normal Mode On, Idle Mode Off, Sleep Out	Yes												
Normal Mode On, Idle Mode On, Sleep Out	Yes												
Partial Mode On, Idle Mode Off, Sleep Out	Yes												
Partial Mode On, Idle Mode On, Sleep Out	Yes												
Sleep In	Yes												
Default	<table border="1"> <thead> <tr> <th>Status</th> <th>Default Value</th> </tr> </thead> <tbody> <tr> <td>Power On Sequence</td> <td>0000h</td> </tr> <tr> <td>S/W Reset</td> <td>0000h</td> </tr> <tr> <td>H/W Reset</td> <td>0000h</td> </tr> </tbody> </table>	Status	Default Value	Power On Sequence	0000h	S/W Reset	0000h	H/W Reset	0000h				
Status	Default Value												
Power On Sequence	0000h												
S/W Reset	0000h												
H/W Reset	0000h												
Flow Chart	<pre> graph TD Start([TE Output On or OFF]) --> SetTear[Set Tear on] SetTear --> LineLSB[/Line N (LSB)/] LineLSB --> LineMSB[/Line N (MSB)/] LineMSB --> End([TE Output ON]) subgraph SequentialTransfer [] SetTear LineLSB LineMSB end </pre> <p>Legend</p> <ul style="list-style-type: none"> Command Parameter Display Action Mode Sequential transfer 												

● TESLRD (45h): Read Scanline

45H	TESLRD (Read ScanLine)																								
Inst / Para	D/CX	WRX	RDX	D17-8	D7	D6	D5	D4	D3	D2	D1	D0	HEX												
GSCAN	0	↑	1	-	0	1	0	0	0	1	0	1	(45h)												
1 st parameter	1	1	↑	-	-	-	-	-	-	-	-	N.8	(00h)												
2 nd parameter	1	1	↑	-	N.7-0							(00h)													
Description	<p>-The display module returns the current scanline ,N, used to update the display device. The total number of scanlines on a display device is defined as VSYNC+VBP+VACT+VFP. The first scanline is defined as the first line of V Sync and is denoted as Line 0.</p> <p>-When in sleep in mode, the value returned by get scanline is undefined.</p> <p>Note: that Set Tear Scan Line with N = 0 is equivalent to Tearing Effect Line ON with M = 0.</p>																								
Restriction	-																								
Register availability	<table border="1"> <thead> <tr> <th>Status</th> <th>Availability</th> </tr> </thead> <tbody> <tr> <td>Normal Mode On, Idle Mode Off, Sleep Out</td> <td>Yes</td> </tr> <tr> <td>Normal Mode On, Idle Mode On, Sleep Out</td> <td>Yes</td> </tr> <tr> <td>Partial Mode On, Idle Mode Off, Sleep Out</td> <td>Yes</td> </tr> <tr> <td>Partial Mode On, Idle Mode On, Sleep Out</td> <td>Yes</td> </tr> <tr> <td>Sleep In</td> <td>Yes</td> </tr> </tbody> </table>													Status	Availability	Normal Mode On, Idle Mode Off, Sleep Out	Yes	Normal Mode On, Idle Mode On, Sleep Out	Yes	Partial Mode On, Idle Mode Off, Sleep Out	Yes	Partial Mode On, Idle Mode On, Sleep Out	Yes	Sleep In	Yes
Status	Availability																								
Normal Mode On, Idle Mode Off, Sleep Out	Yes																								
Normal Mode On, Idle Mode On, Sleep Out	Yes																								
Partial Mode On, Idle Mode Off, Sleep Out	Yes																								
Partial Mode On, Idle Mode On, Sleep Out	Yes																								
Sleep In	Yes																								
Default	<table border="1"> <thead> <tr> <th>Status</th> <th>Default Value</th> </tr> </thead> <tbody> <tr> <td>Power On Sequence</td> <td>0000h</td> </tr> <tr> <td>S/W Reset</td> <td>0000h</td> </tr> <tr> <td>H/W Reset</td> <td>0000h</td> </tr> </tbody> </table>													Status	Default Value	Power On Sequence	0000h	S/W Reset	0000h	H/W Reset	0000h				
Status	Default Value																								
Power On Sequence	0000h																								
S/W Reset	0000h																								
H/W Reset	0000h																								

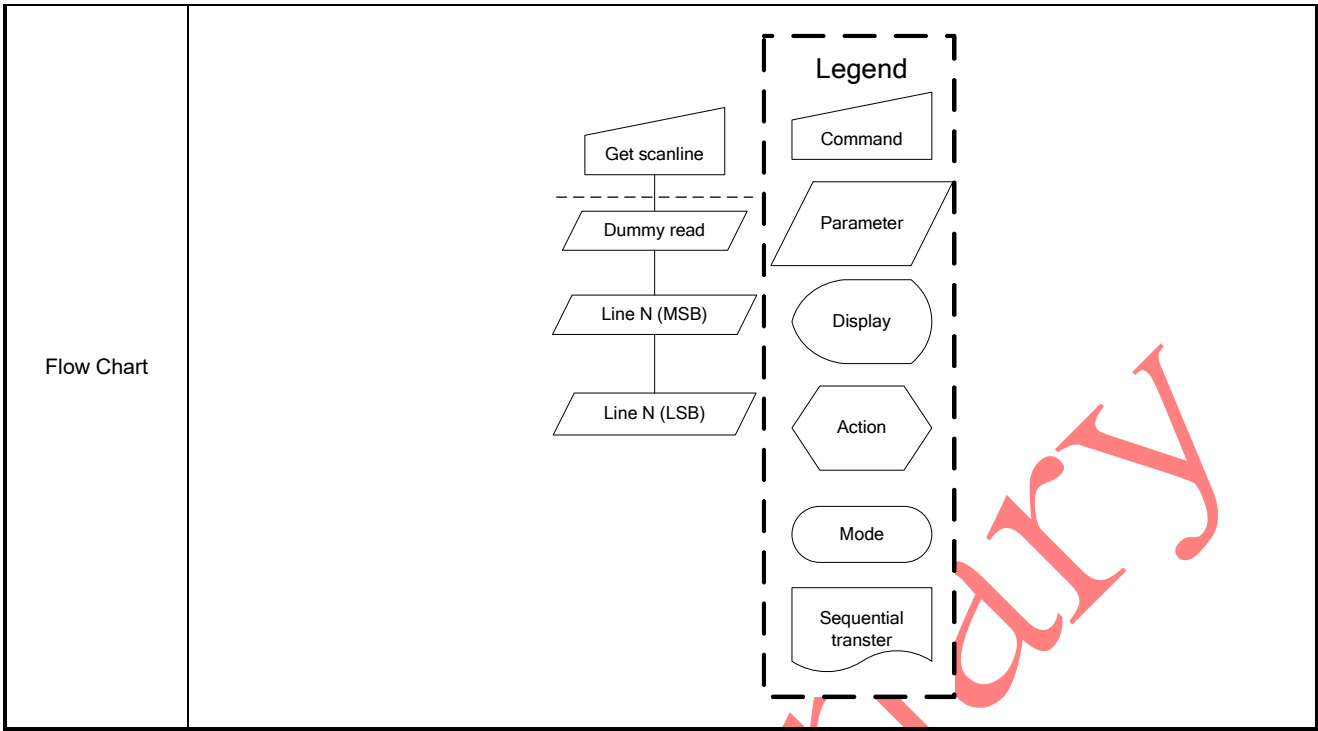

● WRIDMC (90h): Write two-color idle Mode color

90H	WRIDMC (Write two –color idle Mode color)																																																
Inst / Para	D/CX	WRX	RDX	D17-8	D7	D6	D5	D4	D3	D2	D1	D0	HEX																																				
WRIDMC	0	↑	1	-	1	0	0	1	0	0	0	0	(90h)																																				
1 st parameter	1	↑	1	-	-	-	-	-	-	R	G	B	(07h)																																				
Description	<p>-The primary color of “Normal Black” panel is black, the secondary color is defined by “Write Idle Mode Color” (90h) command</p> <table border="1"> <thead> <tr> <th>1bpp idle mode color selection</th> <th>R</th> <th>G</th> <th>B</th> </tr> </thead> <tbody> <tr> <td>Black</td> <td>0</td> <td>0</td> <td>0</td> </tr> <tr> <td>Blue</td> <td>0</td> <td>0</td> <td>1</td> </tr> <tr> <td>Green</td> <td>0</td> <td>1</td> <td>0</td> </tr> <tr> <td>Cyan</td> <td>0</td> <td>1</td> <td>1</td> </tr> <tr> <td>Red</td> <td>1</td> <td>0</td> <td>0</td> </tr> <tr> <td>Magenta</td> <td>1</td> <td>0</td> <td>1</td> </tr> <tr> <td>Yellow</td> <td>1</td> <td>1</td> <td>0</td> </tr> <tr> <td>White</td> <td>1</td> <td>1</td> <td>1</td> </tr> </tbody> </table>													1bpp idle mode color selection	R	G	B	Black	0	0	0	Blue	0	0	1	Green	0	1	0	Cyan	0	1	1	Red	1	0	0	Magenta	1	0	1	Yellow	1	1	0	White	1	1	1
1bpp idle mode color selection	R	G	B																																														
Black	0	0	0																																														
Blue	0	0	1																																														
Green	0	1	0																																														
Cyan	0	1	1																																														
Red	1	0	0																																														
Magenta	1	0	1																																														
Yellow	1	1	0																																														
White	1	1	1																																														
Register availability	<table border="1"> <thead> <tr> <th>Status</th> <th>Availability</th> </tr> </thead> <tbody> <tr> <td>Normal Mode On, Idle Mode Off, Sleep Out</td> <td>Yes</td> </tr> <tr> <td>Normal Mode On, Idle Mode On, Sleep Out</td> <td>Yes</td> </tr> <tr> <td>Partial Mode On, Idle Mode Off, Sleep Out</td> <td>Yes</td> </tr> </tbody> </table>													Status	Availability	Normal Mode On, Idle Mode Off, Sleep Out	Yes	Normal Mode On, Idle Mode On, Sleep Out	Yes	Partial Mode On, Idle Mode Off, Sleep Out	Yes																												
Status	Availability																																																
Normal Mode On, Idle Mode Off, Sleep Out	Yes																																																
Normal Mode On, Idle Mode On, Sleep Out	Yes																																																
Partial Mode On, Idle Mode Off, Sleep Out	Yes																																																

		Partial Mode On, Idle Mode On, Sleep Out	Yes								
		Sleep In	Yes								
Default	<table border="1"> <thead> <tr> <th>Status</th> <th>Default Value</th> </tr> </thead> <tbody> <tr> <td>Power On Sequence</td> <td>0000h</td> </tr> <tr> <td>S/W Reset</td> <td>0000h</td> </tr> <tr> <td>H/W Reset</td> <td>0000h</td> </tr> </tbody> </table>			Status	Default Value	Power On Sequence	0000h	S/W Reset	0000h	H/W Reset	0000h
	Status	Default Value									
	Power On Sequence	0000h									
	S/W Reset	0000h									
H/W Reset	0000h										

● RDIDMC (91h): Read two-color idle Mode color

91H	RDIDMC (Read two –color idle Mode color)																																															
Inst / Para	D/CX	WRX	RDX	D17-8	D7	D6	D5	D4	D3	D2	D1	D0	HEX																																			
RDIDMC	0	↑	1	-	1	0	0	1	0	0	0	1	(91h)																																			
1 st parameter	1	1	↑	-	-	-	-	-	-	R	G	B	(07h)																																			
Description	This command indicates the two color current status of the display as described in the table below:																																															
	<table border="1"> <thead> <tr> <th>1bpp idle mode color selection</th> <th>R</th> <th>G</th> <th>B</th> </tr> </thead> <tbody> <tr> <td>Black</td> <td>0</td> <td>0</td> <td>0</td> </tr> <tr> <td>Blue</td> <td>0</td> <td>0</td> <td>1</td> </tr> <tr> <td>Green</td> <td>0</td> <td>1</td> <td>0</td> </tr> <tr> <td>Cyan</td> <td>0</td> <td>1</td> <td>1</td> </tr> <tr> <td>Red</td> <td>1</td> <td>0</td> <td>0</td> </tr> <tr> <td>Magenta</td> <td>1</td> <td>0</td> <td>1</td> </tr> <tr> <td>Yellow</td> <td>1</td> <td>1</td> <td>0</td> </tr> <tr> <td>White</td> <td>1</td> <td>1</td> <td>1</td> </tr> </tbody> </table>													1bpp idle mode color selection	R	G	B	Black	0	0	0	Blue	0	0	1	Green	0	1	0	Cyan	0	1	1	Red	1	0	0	Magenta	1	0	1	Yellow	1	1	0	White	1	1
1bpp idle mode color selection	R	G	B																																													
Black	0	0	0																																													
Blue	0	0	1																																													
Green	0	1	0																																													
Cyan	0	1	1																																													
Red	1	0	0																																													
Magenta	1	0	1																																													
Yellow	1	1	0																																													
White	1	1	1																																													
Register availability	<table border="1"> <thead> <tr> <th>Status</th> <th>Availability</th> </tr> </thead> <tbody> <tr> <td>Normal Mode On, Idle Mode Off, Sleep Out</td> <td>Yes</td> </tr> <tr> <td>Normal Mode On, Idle Mode On, Sleep Out</td> <td>Yes</td> </tr> <tr> <td>Partial Mode On, Idle Mode Off, Sleep Out</td> <td>Yes</td> </tr> <tr> <td>Partial Mode On, Idle Mode On, Sleep Out</td> <td>Yes</td> </tr> <tr> <td>Sleep In</td> <td>Yes</td> </tr> </tbody> </table>													Status	Availability	Normal Mode On, Idle Mode Off, Sleep Out	Yes	Normal Mode On, Idle Mode On, Sleep Out	Yes	Partial Mode On, Idle Mode Off, Sleep Out	Yes	Partial Mode On, Idle Mode On, Sleep Out	Yes	Sleep In	Yes																							
	Status	Availability																																														
	Normal Mode On, Idle Mode Off, Sleep Out	Yes																																														
	Normal Mode On, Idle Mode On, Sleep Out	Yes																																														
	Partial Mode On, Idle Mode Off, Sleep Out	Yes																																														
	Partial Mode On, Idle Mode On, Sleep Out	Yes																																														
Sleep In	Yes																																															
Default	<table border="1"> <thead> <tr> <th>Status</th> <th>Default Value</th> </tr> </thead> <tbody> <tr> <td>Power On Sequence</td> <td>0000h</td> </tr> <tr> <td>S/W Reset</td> <td>0000h</td> </tr> <tr> <td>H/W Reset</td> <td>0000h</td> </tr> </tbody> </table>													Status	Default Value	Power On Sequence	0000h	S/W Reset	0000h	H/W Reset	0000h																											
	Status	Default Value																																														
	Power On Sequence	0000h																																														
	S/W Reset	0000h																																														
H/W Reset	0000h																																															

● HS(60h): Horizontal SYNC Command

60H	Horizontal SYNC Command																						
Inst / Para	D/CX	WRX	RDX	D17-8	D7	D6	D5	D4	D3	D2	D1	D0	HEX										
HS	0	↑	1	-	0	1	1	0	0	0	0	0	(60h)										
parameter	No Parameter																						
Description	- <i>Horizontal SYNC Command</i>																						
Register availability	<table border="1"> <tr> <td>Normal Mode On, Idle Mode Off, Sleep Out</td> <td>Yes</td> </tr> <tr> <td>Normal Mode On, Idle Mode On, Sleep Out</td> <td>Yes</td> </tr> <tr> <td>Partial Mode On, Idle Mode Off, Sleep Out</td> <td>Yes</td> </tr> <tr> <td>Partial Mode On, Idle Mode On, Sleep Out</td> <td>Yes</td> </tr> <tr> <td>Sleep In</td> <td>Yes</td> </tr> </table>													Normal Mode On, Idle Mode Off, Sleep Out	Yes	Normal Mode On, Idle Mode On, Sleep Out	Yes	Partial Mode On, Idle Mode Off, Sleep Out	Yes	Partial Mode On, Idle Mode On, Sleep Out	Yes	Sleep In	Yes
Normal Mode On, Idle Mode Off, Sleep Out	Yes																						
Normal Mode On, Idle Mode On, Sleep Out	Yes																						
Partial Mode On, Idle Mode Off, Sleep Out	Yes																						
Partial Mode On, Idle Mode On, Sleep Out	Yes																						
Sleep In	Yes																						
Default	<table border="1"> <thead> <tr> <th>Status</th> <th>Default Value</th> </tr> </thead> <tbody> <tr> <td>Power On Sequence</td> <td>Off</td> </tr> <tr> <td>S/W Reset</td> <td>Off</td> </tr> <tr> <td>H/W Reset</td> <td>Off</td> </tr> </tbody> </table>													Status	Default Value	Power On Sequence	Off	S/W Reset	Off	H/W Reset	Off		
Status	Default Value																						
Power On Sequence	Off																						
S/W Reset	Off																						
H/W Reset	Off																						

● VS(61h): Vertical SYNC Command

61H	Vertical SYNC Command																						
Inst / Para	D/CX	WRX	RDX	D17-8	D7	D6	D5	D4	D3	D2	D1	D0	HEX										
HS	0	↑	1	-	0	1	1	0	0	0	0	1	(61h)										
parameter	No Parameter																						
Description	- <i>Vertical SYNC Command</i> <i>HS signals without data --> HS signal only</i>																						
Register availability	<table border="1"> <tr> <td>Normal Mode On, Idle Mode Off, Sleep Out</td> <td>Yes</td> </tr> <tr> <td>Normal Mode On, Idle Mode On, Sleep Out</td> <td>Yes</td> </tr> <tr> <td>Partial Mode On, Idle Mode Off, Sleep Out</td> <td>Yes</td> </tr> <tr> <td>Partial Mode On, Idle Mode On, Sleep Out</td> <td>Yes</td> </tr> <tr> <td>Sleep In</td> <td>Yes</td> </tr> </table>													Normal Mode On, Idle Mode Off, Sleep Out	Yes	Normal Mode On, Idle Mode On, Sleep Out	Yes	Partial Mode On, Idle Mode Off, Sleep Out	Yes	Partial Mode On, Idle Mode On, Sleep Out	Yes	Sleep In	Yes
Normal Mode On, Idle Mode Off, Sleep Out	Yes																						
Normal Mode On, Idle Mode On, Sleep Out	Yes																						
Partial Mode On, Idle Mode Off, Sleep Out	Yes																						
Partial Mode On, Idle Mode On, Sleep Out	Yes																						
Sleep In	Yes																						
Default	<table border="1"> <thead> <tr> <th>Status</th> <th>Default Value</th> </tr> </thead> <tbody> <tr> <td>Power On Sequence</td> <td>Off</td> </tr> <tr> <td>S/W Reset</td> <td>Off</td> </tr> <tr> <td>H/W Reset</td> <td>Off</td> </tr> </tbody> </table>													Status	Default Value	Power On Sequence	Off	S/W Reset	Off	H/W Reset	Off		
Status	Default Value																						
Power On Sequence	Off																						
S/W Reset	Off																						
H/W Reset	Off																						

11.3. Command Table 2

● CK (F0h): Command Key

● F0H	Command Key																								
Inst / Para	D/CX	WRX	RDX	D17-8	D7	D6	D5	D4	D3	D2	D1	D0	HEX												
CK	0	↑	1	-	1	1	1	1	0	0	0	0	(F0h)												
parameter	1	↑	1	-	CMDSET.7-0							(00h)-													
Description	-CMDSET.7-0: Command set control code.																								
	<table border="1"> <thead> <tr> <th>CMDSET.7-0</th> <th>Description</th> </tr> </thead> <tbody> <tr> <td>C3h 96h</td> <td>Enable access to command tablez</td> </tr> <tr> <td>3Ch 69h</td> <td>Turn off command tablez</td> </tr> </tbody> </table>		CMDSET.7-0	Description	C3h 96h	Enable access to command tablez	3Ch 69h	Turn off command tablez																	
CMDSET.7-0	Description																								
C3h 96h	Enable access to command tablez																								
3Ch 69h	Turn off command tablez																								
⚠: Don't care.																									
Register availability	<table border="1"> <thead> <tr> <th>Status</th> <th>Availability</th> </tr> </thead> <tbody> <tr> <td>Normal Mode On, Idle Mode Off, Sleep Out</td> <td>Yes</td> </tr> <tr> <td>Normal Mode On, Idle Mode On, Sleep Out</td> <td>Yes</td> </tr> <tr> <td>Partial Mode On, Idle Mode Off, Sleep Out</td> <td>Yes</td> </tr> <tr> <td>Partial Mode On, Idle Mode On, Sleep Out</td> <td>Yes</td> </tr> <tr> <td>Sleep In</td> <td>Yes</td> </tr> </tbody> </table>													Status	Availability	Normal Mode On, Idle Mode Off, Sleep Out	Yes	Normal Mode On, Idle Mode On, Sleep Out	Yes	Partial Mode On, Idle Mode Off, Sleep Out	Yes	Partial Mode On, Idle Mode On, Sleep Out	Yes	Sleep In	Yes
	Status	Availability																							
Normal Mode On, Idle Mode Off, Sleep Out	Yes																								
Normal Mode On, Idle Mode On, Sleep Out	Yes																								
Partial Mode On, Idle Mode Off, Sleep Out	Yes																								
Partial Mode On, Idle Mode On, Sleep Out	Yes																								
Sleep In	Yes																								
Default	<table border="1"> <thead> <tr> <th>Status</th> <th>Default Value</th> </tr> </thead> <tbody> <tr> <td>Power On Sequence</td> <td>00h</td> </tr> <tr> <td>S/W Reset</td> <td>00h</td> </tr> <tr> <td>H/W Reset</td> <td>00h</td> </tr> </tbody> </table>													Status	Default Value	Power On Sequence	00h	S/W Reset	00h	H/W Reset	00h				
	Status	Default Value																							
Power On Sequence	00h																								
S/W Reset	00h																								
H/W Reset	00h																								

● ECFC (B0h): Entry Code Function Control

B0H	Entry Code Function Control												HEX											
Inst / Para	D/CX	WRX	RDX	D17-8	D7	D6	D5	D4	D3	D2	D1	D0	HEX											
ECFC	0	↑	1	-	1	0	1	1	0	0	0	0	(B0h)											
parameter	1	↑	1	-	EC.7-0							(02h)-												
Description	-Entry code to initiate specific operation																							
	<table border="1"> <thead> <tr> <th>EC.7-0</th> <th>Operation</th> </tr> </thead> <tbody> <tr> <td>0xA5</td> <td>Enable test image generation (Reading of CmdoxBo.Po[0] = PG_GO = 1)</td> </tr> <tr> <td>0x5A</td> <td>Disable test image generation (Reading of CmdoxBo.Po[0] = PG_GO = 0) (Default)</td> </tr> <tr> <td>0xC3</td> <td>Enable use of 8-color idle mode (Reading of CmdoxBo.Po[1] = TCS = 0)</td> </tr> <tr> <td>0x3C</td> <td>Enable use of 2-color idle mode (Reading of CmdoxBo.Po[1] = TCS = 1) (Default)</td> </tr> </tbody> </table>													EC.7-0	Operation	0xA5	Enable test image generation (Reading of CmdoxBo.Po[0] = PG_GO = 1)	0x5A	Disable test image generation (Reading of CmdoxBo.Po[0] = PG_GO = 0) (Default)	0xC3	Enable use of 8-color idle mode (Reading of CmdoxBo.Po[1] = TCS = 0)	0x3C	Enable use of 2-color idle mode (Reading of CmdoxBo.Po[1] = TCS = 1) (Default)	
EC.7-0	Operation																							
0xA5	Enable test image generation (Reading of CmdoxBo.Po[0] = PG_GO = 1)																							
0x5A	Disable test image generation (Reading of CmdoxBo.Po[0] = PG_GO = 0) (Default)																							
0xC3	Enable use of 8-color idle mode (Reading of CmdoxBo.Po[1] = TCS = 0)																							
0x3C	Enable use of 2-color idle mode (Reading of CmdoxBo.Po[1] = TCS = 1) (Default)																							
'-: Don't care.																								
Register availability	<table border="1"> <thead> <tr> <th>Status</th> <th>Availability</th> </tr> </thead> <tbody> <tr> <td>Normal Mode On, Idle Mode Off, Sleep Out</td> <td>Yes</td> </tr> <tr> <td>Normal Mode On, Idle Mode On, Sleep Out</td> <td>Yes</td> </tr> <tr> <td>Partial Mode On, Idle Mode Off, Sleep Out</td> <td>Yes</td> </tr> <tr> <td>Partial Mode On, Idle Mode On, Sleep Out</td> <td>Yes</td> </tr> <tr> <td>Sleep In</td> <td>Yes</td> </tr> </tbody> </table>												Status	Availability	Normal Mode On, Idle Mode Off, Sleep Out	Yes	Normal Mode On, Idle Mode On, Sleep Out	Yes	Partial Mode On, Idle Mode Off, Sleep Out	Yes	Partial Mode On, Idle Mode On, Sleep Out	Yes	Sleep In	Yes
	Status	Availability																						
	Normal Mode On, Idle Mode Off, Sleep Out	Yes																						
	Normal Mode On, Idle Mode On, Sleep Out	Yes																						
	Partial Mode On, Idle Mode Off, Sleep Out	Yes																						
Partial Mode On, Idle Mode On, Sleep Out	Yes																							
Sleep In	Yes																							
Default	<table border="1"> <thead> <tr> <th>Status</th> <th>Default Value</th> </tr> </thead> <tbody> <tr> <td>Power On Sequence</td> <td>02h</td> </tr> <tr> <td>S/W Reset</td> <td>02h</td> </tr> <tr> <td>H/W Reset</td> <td>02h</td> </tr> </tbody> </table>												Status	Default Value	Power On Sequence	02h	S/W Reset	02h	H/W Reset	02h				
	Status	Default Value																						
	Power On Sequence	02h																						
	S/W Reset	02h																						
H/W Reset	02h																							

● FRC1 (B1h): Frame Rate Control 1

B1H	Frame Rate Control 1																								
Inst / Para	D/CX	WRX	RDX	D17-8	D7	D6	D5	D4	D3	D2	D1	D0	HEX												
FRC1	0	↑	1	-	1	0	1	1	0	0	0	1	(B1h)												
1 st parameter	1	↑	1	-	FRS.7-0							(Fah)													
2 nd parameter	1	↑	1	-	RTN.7-0							(C6h)													
Description	<p>-FRS.7-0: frame rate coarse tune for idle mode.</p> <p>-RTN.7-0: frame rate fine tune for idle mode, 1 idle mode line period = 168 + RTN.7-0 + 256 x ((255 – FRS.7-0) (cycles)</p> <p>'-': Don't care.</p>																								
Register availability	<table border="1"> <thead> <tr> <th>Status</th> <th>Availability</th> </tr> </thead> <tbody> <tr> <td>Normal Mode On, Idle Mode Off, Sleep Out</td> <td>Yes</td> </tr> <tr> <td>Normal Mode On, Idle Mode On, Sleep Out</td> <td>Yes</td> </tr> <tr> <td>Partial Mode On, Idle Mode Off, Sleep Out</td> <td>Yes</td> </tr> <tr> <td>Partial Mode On, Idle Mode On, Sleep Out</td> <td>Yes</td> </tr> <tr> <td>Sleep In</td> <td>Yes</td> </tr> </tbody> </table>													Status	Availability	Normal Mode On, Idle Mode Off, Sleep Out	Yes	Normal Mode On, Idle Mode On, Sleep Out	Yes	Partial Mode On, Idle Mode Off, Sleep Out	Yes	Partial Mode On, Idle Mode On, Sleep Out	Yes	Sleep In	Yes
Status	Availability																								
Normal Mode On, Idle Mode Off, Sleep Out	Yes																								
Normal Mode On, Idle Mode On, Sleep Out	Yes																								
Partial Mode On, Idle Mode Off, Sleep Out	Yes																								
Partial Mode On, Idle Mode On, Sleep Out	Yes																								
Sleep In	Yes																								
Default	<table border="1"> <thead> <tr> <th>Status</th> <th>Default Value</th> </tr> </thead> <tbody> <tr> <td>Power On Sequence</td> <td>Fah/C6h</td> </tr> <tr> <td>S/W Reset</td> <td>Fah/C6h</td> </tr> <tr> <td>H/W Reset</td> <td>Fah/C6h</td> </tr> </tbody> </table>													Status	Default Value	Power On Sequence	Fah/C6h	S/W Reset	Fah/C6h	H/W Reset	Fah/C6h				
Status	Default Value																								
Power On Sequence	Fah/C6h																								
S/W Reset	Fah/C6h																								
H/W Reset	Fah/C6h																								

● GSC (B2h): Gate Scan Control

B2H	Gate Scan Control																										
Inst / Para	D/CX	WRX	RDX	D17-8	D7	D6	D5	D4	D3	D2	D1	D0	HEX														
GSC	0	↑	1	-	1	0	1	1	0	0	1	0	(B2h)														
parameter	1	↑	1	-	-	-	-	FGS	ML_GS_REV	GS.2-0		(10h)															
Description	<p>-GS.2-0: Odd/Even gate drive order.</p> <table border="1"> <thead> <tr> <th>GS.1-0</th> <th>Gate drive order</th> </tr> </thead> <tbody> <tr> <td>3'b000</td> <td>z-drive (odd,even,odd,even) for every frame</td> </tr> <tr> <td>3'b001</td> <td>reversed z-drive (even,odd,even,odd) for every frame</td> </tr> <tr> <td>3'b010</td> <td>bow-drive (odd,even,even,odd) for every frame</td> </tr> <tr> <td>3'b011</td> <td>reversed bow-drive (even,odd,odd,even) for every frame</td> </tr> <tr> <td>3'b10x</td> <td>z and reversed z-drive alternately by frame</td> </tr> <tr> <td>3'b11x</td> <td>bow and reversed bow-drive alternately by frame</td> </tr> </tbody> </table> <p>-ML_GS_REV: Invert GS[0] (ex., Z to rev-Z) if ML=1.</p> <p>-FGS: 1: to reverse gate drive right/left side order, 0: not reversed.</p> <p>'-': Don't care.</p>													GS.1-0	Gate drive order	3'b000	z-drive (odd,even,odd,even) for every frame	3'b001	reversed z-drive (even,odd,even,odd) for every frame	3'b010	bow-drive (odd,even,even,odd) for every frame	3'b011	reversed bow-drive (even,odd,odd,even) for every frame	3'b10x	z and reversed z-drive alternately by frame	3'b11x	bow and reversed bow-drive alternately by frame
GS.1-0	Gate drive order																										
3'b000	z-drive (odd,even,odd,even) for every frame																										
3'b001	reversed z-drive (even,odd,even,odd) for every frame																										
3'b010	bow-drive (odd,even,even,odd) for every frame																										
3'b011	reversed bow-drive (even,odd,odd,even) for every frame																										
3'b10x	z and reversed z-drive alternately by frame																										
3'b11x	bow and reversed bow-drive alternately by frame																										

Register availability	<table border="1"> <thead> <tr> <th>Status</th> <th>Availability</th> </tr> </thead> <tbody> <tr> <td>Normal Mode On, Idle Mode Off, Sleep Out</td> <td>Yes</td> </tr> <tr> <td>Normal Mode On, Idle Mode On, Sleep Out</td> <td>Yes</td> </tr> <tr> <td>Partial Mode On, Idle Mode Off, Sleep Out</td> <td>Yes</td> </tr> <tr> <td>Partial Mode On, Idle Mode On, Sleep Out</td> <td>Yes</td> </tr> <tr> <td>Sleep In</td> <td>Yes</td> </tr> </tbody> </table>	Status	Availability	Normal Mode On, Idle Mode Off, Sleep Out	Yes	Normal Mode On, Idle Mode On, Sleep Out	Yes	Partial Mode On, Idle Mode Off, Sleep Out	Yes	Partial Mode On, Idle Mode On, Sleep Out	Yes	Sleep In	Yes
	Status	Availability											
	Normal Mode On, Idle Mode Off, Sleep Out	Yes											
	Normal Mode On, Idle Mode On, Sleep Out	Yes											
	Partial Mode On, Idle Mode Off, Sleep Out	Yes											
	Partial Mode On, Idle Mode On, Sleep Out	Yes											
Sleep In	Yes												
Default	<table border="1"> <thead> <tr> <th>Status</th> <th>Default Value</th> </tr> </thead> <tbody> <tr> <td>Power On Sequence</td> <td>10h</td> </tr> <tr> <td>S/W Reset</td> <td>10h</td> </tr> <tr> <td>H/W Reset</td> <td>10h</td> </tr> </tbody> </table>	Status	Default Value	Power On Sequence	10h	S/W Reset	10h	H/W Reset	10h				
	Status	Default Value											
	Power On Sequence	10h											
	S/W Reset	10h											
H/W Reset	10h												

● VDMDC (B3h): Video Mode Display Control

B3H	Video Mode Display Control												HEX													
Inst / Para	D/CX	WRX	RDX	D17-8	D7	D6	D5	D4	D3	D2	D1	D0	HEX													
VDMDC	0	↑	1	-	1	0	1	1	0	0	1	1	(B3h)													
parameter	1	↑	1	-	-	-	-	-	DINV_A.3-0			(01h)														
Description	-DINV.1-0: Panel inversion mode setting for video mode.																									
	<table border="1"> <thead> <tr> <th>DINV.3-0</th> <th>Mode</th> </tr> </thead> <tbody> <tr> <td>0000</td> <td>Reserved</td> </tr> <tr> <td>0001</td> <td>1-dot inversion</td> </tr> <tr> <td>0010</td> <td>2-dot inversion</td> </tr> <tr> <td>0011</td> <td>3-dot inversion</td> </tr> <tr> <td>:</td> <td>:</td> </tr> <tr> <td>1111</td> <td>15-dot inversion</td> </tr> </tbody> </table>													DINV.3-0	Mode	0000	Reserved	0001	1-dot inversion	0010	2-dot inversion	0011	3-dot inversion	:	:	1111
DINV.3-0	Mode																									
0000	Reserved																									
0001	1-dot inversion																									
0010	2-dot inversion																									
0011	3-dot inversion																									
:	:																									
1111	15-dot inversion																									
Register availability	<table border="1"> <thead> <tr> <th>Status</th> <th>Availability</th> </tr> </thead> <tbody> <tr> <td>Normal Mode On, Idle Mode Off, Sleep Out</td> <td>Yes</td> </tr> <tr> <td>Normal Mode On, Idle Mode On, Sleep Out</td> <td>Yes</td> </tr> <tr> <td>Partial Mode On, Idle Mode Off, Sleep Out</td> <td>Yes</td> </tr> <tr> <td>Partial Mode On, Idle Mode On, Sleep Out</td> <td>Yes</td> </tr> <tr> <td>Sleep In</td> <td>Yes</td> </tr> </tbody> </table>													Status	Availability	Normal Mode On, Idle Mode Off, Sleep Out	Yes	Normal Mode On, Idle Mode On, Sleep Out	Yes	Partial Mode On, Idle Mode Off, Sleep Out	Yes	Partial Mode On, Idle Mode On, Sleep Out	Yes	Sleep In	Yes	
	Status	Availability																								
	Normal Mode On, Idle Mode Off, Sleep Out	Yes																								
	Normal Mode On, Idle Mode On, Sleep Out	Yes																								
	Partial Mode On, Idle Mode Off, Sleep Out	Yes																								
	Partial Mode On, Idle Mode On, Sleep Out	Yes																								
Sleep In	Yes																									

Default	Status	Default Value
	Power On Sequence	01h
	S/W Reset	01h
	H/W Reset	01h

● TCMDC (B4h): Two color Mode Display Control

B4H	Two color Mode Display Control																									
Inst / Para	D/CX	WRX	RDX	D17-8	D7	D6	D5	D4	D3	D2	D1	D0	HEX													
TCMDC	0	↑	1	-	1	0	1	1	0	1	0	0	(B4h)													
parameter	1	↑	1	-	-	-	-	-	DINV_B.3-0			(01h)														
Description	-DINV.1-0: Panel inversion mode setting for Two color mode.																									
	<table border="1"> <thead> <tr> <th>DINV.3-0</th> <th>Mode</th> </tr> </thead> <tbody> <tr> <td>0000</td> <td>Reserved</td> </tr> <tr> <td>0001</td> <td>1-dot inversion</td> </tr> <tr> <td>0010</td> <td>2-dot inversion</td> </tr> <tr> <td>0011</td> <td>3-dot inversion</td> </tr> <tr> <td>:</td> <td>:</td> </tr> <tr> <td>1111</td> <td>15-dot inversion</td> </tr> </tbody> </table> <p>': Don't care.</p>													DINV.3-0	Mode	0000	Reserved	0001	1-dot inversion	0010	2-dot inversion	0011	3-dot inversion	:	:	1111
DINV.3-0	Mode																									
0000	Reserved																									
0001	1-dot inversion																									
0010	2-dot inversion																									
0011	3-dot inversion																									
:	:																									
1111	15-dot inversion																									
Register availability	<table border="1"> <thead> <tr> <th>Status</th> <th>Availability</th> </tr> </thead> <tbody> <tr> <td>Normal Mode On, Idle Mode Off, Sleep Out</td> <td>Yes</td> </tr> <tr> <td>Normal Mode On, Idle Mode On, Sleep Out</td> <td>Yes</td> </tr> <tr> <td>Partial Mode On, Idle Mode Off, Sleep Out</td> <td>Yes</td> </tr> <tr> <td>Partial Mode On, Idle Mode On, Sleep Out</td> <td>Yes</td> </tr> <tr> <td>Sleep In</td> <td>Yes</td> </tr> </tbody> </table>												Status	Availability	Normal Mode On, Idle Mode Off, Sleep Out	Yes	Normal Mode On, Idle Mode On, Sleep Out	Yes	Partial Mode On, Idle Mode Off, Sleep Out	Yes	Partial Mode On, Idle Mode On, Sleep Out	Yes	Sleep In	Yes		
	Status	Availability																								
	Normal Mode On, Idle Mode Off, Sleep Out	Yes																								
	Normal Mode On, Idle Mode On, Sleep Out	Yes																								
	Partial Mode On, Idle Mode Off, Sleep Out	Yes																								
Partial Mode On, Idle Mode On, Sleep Out	Yes																									
Sleep In	Yes																									
Default	Status	Default Value																								
	Power On Sequence	01h																								
	S/W Reset	01h																								
	H/W Reset	01h																								

● BPC (B5h): Blank Porch Control

B5H	Blank Porch Control												HEX												
Inst / Para	D/CX	WRX	RDX	D17-8	D7	D6	D5	D4	D3	D2	D1	D0	HEX												
BPC	0	↑	1	-	1	0	1	1	0	1	0	1	(B5h)												
1 st parameter	1	↑	1	-	VFP.15-8							(00h)													
2 nd parameter	1	↑	1	-	VFP.7-0							(02h)													
3 rd parameter	1	↑	1	-	VBP.15-8							(00h)													
4 th parameter	1	↑	1	-	VBP.7-0							(03h)													
Description	<p>-VFP.15-0: The number of lines in vertical front porch period for idle mode. -VBP.15-0: The number of lines in vertical back porch period for idle mode. Note that valid range of VFP and VBP are between 2 and 65535. When in idle mode, hardware uses VFP.15-0 and VBP.15-0 for porch control. "- " Don't care</p>																								
Register availability	<table border="1"> <thead> <tr> <th>Status</th> <th>Availability</th> </tr> </thead> <tbody> <tr> <td>Normal Mode On, Idle Mode Off, Sleep Out</td> <td>Yes</td> </tr> <tr> <td>Normal Mode On, Idle Mode On, Sleep Out</td> <td>Yes</td> </tr> <tr> <td>Partial Mode On, Idle Mode Off, Sleep Out</td> <td>Yes</td> </tr> <tr> <td>Partial Mode On, Idle Mode On, Sleep Out</td> <td>Yes</td> </tr> <tr> <td>● Sleep In</td> <td>Yes</td> </tr> </tbody> </table>													Status	Availability	Normal Mode On, Idle Mode Off, Sleep Out	Yes	Normal Mode On, Idle Mode On, Sleep Out	Yes	Partial Mode On, Idle Mode Off, Sleep Out	Yes	Partial Mode On, Idle Mode On, Sleep Out	Yes	● Sleep In	Yes
Status	Availability																								
Normal Mode On, Idle Mode Off, Sleep Out	Yes																								
Normal Mode On, Idle Mode On, Sleep Out	Yes																								
Partial Mode On, Idle Mode Off, Sleep Out	Yes																								
Partial Mode On, Idle Mode On, Sleep Out	Yes																								
● Sleep In	Yes																								
Default	<table border="1"> <thead> <tr> <th>Status</th> <th>Default Value</th> </tr> </thead> <tbody> <tr> <td>Power On Sequence</td> <td>00h</td> </tr> <tr> <td>S/W Reset</td> <td>00h</td> </tr> <tr> <td>H/W Reset</td> <td>00h</td> </tr> </tbody> </table>													Status	Default Value	Power On Sequence	00h	S/W Reset	00h	H/W Reset	00h				
Status	Default Value																								
Power On Sequence	00h																								
S/W Reset	00h																								
H/W Reset	00h																								

● DISCN(B6h): Display Function Control

B6H	Display Function Control												HEX
Inst / Para	D/CX	WRX	RDX	D17-8	D7	D6	D5	D4	D3	D2	D1	D0	HEX
DISCN	0	↑	1	-	1	0	1	1	0	1	1	0	(B6h)
1 st parameter	1	↑	1	-	NL.7-0 (Y Resolution)							(C7h)	
2 nd parameter	1	↑	1	-	-	-	NC.5-0 (X Resolution)					(31h)	
Description	<p>-NL.6-0: Set the number of lines to drive the LCD at an interval of 2 lines. The # of display Gates = 2 x (NL.6-0 + 1). -NC.5-0: Set the number of columns to drive the LCD at an interval of 8 columns. Lines = 8 x (NC.5-0 + 1) NL.6-0 = 1~0xC7; NC.5-0 = 1~0x31. Example: 240RGBx240 setting is 0x77, 0x1D ; 400RGBx400 setting is 0xC7, 0x31</p>												

Register availability	Status		Availability
	Normal Mode On, Idle Mode Off, Sleep Out		Yes
	Normal Mode On, Idle Mode On, Sleep Out		Yes
	Partial Mode On, Idle Mode Off, Sleep Out		Yes
	Partial Mode On, Idle Mode On, Sleep Out		Yes
	Sleep In		Yes
Default	Status		Default Value
	Power On Sequence		NA
	S/W Reset		NA
	H/W Reset		NA

● EMSET (B7h): Entry Mode Set

B7H	Entry Mode Set												HEX
Inst / Para	D/CX	WRX	RDX	D17-8	D7	D6	D5	D4	D3	D2	D1	D0	
BPC	0	↑	1	-	1	0	1	1	0	1	1	1	(B7h)
parameter	1	↑	1	-	-	-	-	-	DSTB	-	-	-	(00h)
Description	<p>-DSTB: Deep standby mode. '1' for going to deep standby mode. In this mode, logic power and SRAM power are turned off.</p> <p>-exit the standby mode: by pull down RESX.</p> <p>"-" Don't care</p>												
Register availability	Status		Availability										
	Normal Mode On, Idle Mode Off, Sleep Out		Yes										
	Normal Mode On, Idle Mode On, Sleep Out		Yes										
	Partial Mode On, Idle Mode Off, Sleep Out		Yes										
	Partial Mode On, Idle Mode On, Sleep Out		Yes										
	Sleep In		Yes										
Default	Status		Default Value										
	Power On Sequence		00h										
	S/W Reset		00h										
	H/W Reset		00h										

● PWR (C0h): Power Control

C0H	Power Control												HEX												
Inst / Para	D/CX	WRX	RDX	D17-8	D7	D6	D5	D4	D3	D2	D1	D0	HEX												
PWR	0	↑	1	-	1	1	0	0	0	0	0	0	(C0h)												
parameter	1	↑	1	-	-	-	-	-	-	ENSWL	SINKVCC[1:0]		(00h)												
Description	<p>-ENSWL: Using with Cmd0xE7,P0(VCCMBYPASS=1 and VCCBYPASS =1)</p> <table border="1"> <thead> <tr> <th>ENSWL</th> <th>VCC Bypass function</th> </tr> </thead> <tbody> <tr> <td>0</td> <td>No action</td> </tr> <tr> <td>1</td> <td>More Stable</td> </tr> </tbody> </table>													ENSWL	VCC Bypass function	0	No action	1	More Stable						
	ENSWL	VCC Bypass function																							
0	No action																								
1	More Stable																								
<p>-SINKVCC:</p> <table border="1"> <thead> <tr> <th>SINKVCC</th> <th>VCC OP stability</th> </tr> </thead> <tbody> <tr> <td>00</td> <td>No action</td> </tr> <tr> <td>01</td> <td>Small</td> </tr> <tr> <td>10</td> <td>Middle</td> </tr> <tr> <td>11</td> <td>Large</td> </tr> </tbody> </table> <p>“-“ Don't care</p>													SINKVCC	VCC OP stability	00	No action	01	Small	10	Middle	11	Large			
SINKVCC	VCC OP stability																								
00	No action																								
01	Small																								
10	Middle																								
11	Large																								
Register availability	<table border="1"> <thead> <tr> <th>Status</th> <th>Availability</th> </tr> </thead> <tbody> <tr> <td>Normal Mode On, Idle Mode Off, Sleep Out</td> <td>Yes</td> </tr> <tr> <td>Normal Mode On, Idle Mode On, Sleep Out</td> <td>Yes</td> </tr> <tr> <td>Partial Mode On, Idle Mode Off, Sleep Out</td> <td>Yes</td> </tr> <tr> <td>Partial Mode On, Idle Mode On, Sleep Out</td> <td>Yes</td> </tr> <tr> <td>Sleep In</td> <td>Yes</td> </tr> </tbody> </table>													Status	Availability	Normal Mode On, Idle Mode Off, Sleep Out	Yes	Normal Mode On, Idle Mode On, Sleep Out	Yes	Partial Mode On, Idle Mode Off, Sleep Out	Yes	Partial Mode On, Idle Mode On, Sleep Out	Yes	Sleep In	Yes
Status	Availability																								
Normal Mode On, Idle Mode Off, Sleep Out	Yes																								
Normal Mode On, Idle Mode On, Sleep Out	Yes																								
Partial Mode On, Idle Mode Off, Sleep Out	Yes																								
Partial Mode On, Idle Mode On, Sleep Out	Yes																								
Sleep In	Yes																								
Default	<table border="1"> <thead> <tr> <th>Status</th> <th>Default Value</th> </tr> </thead> <tbody> <tr> <td>Power On Sequence</td> <td>00h</td> </tr> <tr> <td>S/W Reset</td> <td>00h</td> </tr> <tr> <td>H/W Reset</td> <td>00h</td> </tr> </tbody> </table>													Status	Default Value	Power On Sequence	00h	S/W Reset	00h	H/W Reset	00h				
Status	Default Value																								
Power On Sequence	00h																								
S/W Reset	00h																								
H/W Reset	00h																								

● PWR1 (C1h): Power Control 1

C1H	Power Control 1																																																																																						
Inst / Para	D/CX	WRX	RDX	D17-8	D7	D6	D5	D4	D3	D2	D1	D0	HEX																																																																										
PWR1	0	↑	1	-	1	1	0	0	0	0	0	1	(C1h)																																																																										
1 st parameter	1	↑	1	-	VGHS2_A.3-0				VGHS1_A.3-0				(44h)																																																																										
2 nd parameter	1	↑	1	-	-	-	-	-	VGLS_A.3-0				(06h)																																																																										
3 rd parameter	1	↑	1	-	VPMS_A.3-0				VNMS_A.3-0				(Ach)																																																																										
4 th parameter	1	↑	1	-	-	-	VRH_A.5-0						(1Bh)																																																																										
Description	<p>-C1h Function for Video mode</p> <p>-VGHS1.3-0: STEP2 VGH voltage level selection.</p> <p>-VGHS2.3-0: STEP2S VGHS voltage level selection.</p> <p>-VGLS.3-0: STEP3 VGL voltage level selection.</p> <table border="1"> <thead> <tr> <th>No.</th> <th>VGHS1.3-0 VGHS2.3-0</th> <th>VGH (V) VGHS(V)</th> <th>VGLS.3-0</th> <th>VGL (V)</th> </tr> </thead> <tbody> <tr><td>0</td><td>0000</td><td>12.541</td><td>0000</td><td>-8.484</td></tr> <tr><td>1</td><td>0001</td><td>12.889</td><td>0001</td><td>-8.773</td></tr> <tr><td>2</td><td>0010</td><td>13.257</td><td>0010</td><td>-9.078</td></tr> <tr><td>3</td><td>0011</td><td>13.647</td><td>0011</td><td>-9.400</td></tr> <tr><td>4</td><td>0100</td><td>14.061</td><td>0100</td><td>-9.741</td></tr> <tr><td>5</td><td>0101</td><td>14.500</td><td>0101</td><td>-10.103</td></tr> <tr><td>6</td><td>0110</td><td>14.968</td><td>0110</td><td>-10.488</td></tr> <tr><td>7</td><td>0111</td><td>15.467</td><td>0111</td><td>-10.897</td></tr> <tr><td>8</td><td>1000</td><td>16.000</td><td>1000</td><td>-11.333</td></tr> <tr><td>9</td><td>1001</td><td rowspan="7">Reserved</td><td>1001</td><td>-11.800</td></tr> <tr><td>10</td><td>1010</td><td>1010</td><td rowspan="7">Reserved</td></tr> <tr><td>11</td><td>1011</td><td>1011</td></tr> <tr><td>12</td><td>1100</td><td>1100</td></tr> <tr><td>13</td><td>1101</td><td>1101</td></tr> <tr><td>14</td><td>1110</td><td>1110</td></tr> <tr><td>15</td><td>1111</td><td>1111</td></tr> </tbody> </table> <p>-VPMS.3-0: STEP1 AVDD voltage level selection.</p> <p>-VNMS.3-0: STEP4 AVEE voltage level selection.</p>													No.	VGHS1.3-0 VGHS2.3-0	VGH (V) VGHS(V)	VGLS.3-0	VGL (V)	0	0000	12.541	0000	-8.484	1	0001	12.889	0001	-8.773	2	0010	13.257	0010	-9.078	3	0011	13.647	0011	-9.400	4	0100	14.061	0100	-9.741	5	0101	14.500	0101	-10.103	6	0110	14.968	0110	-10.488	7	0111	15.467	0111	-10.897	8	1000	16.000	1000	-11.333	9	1001	Reserved	1001	-11.800	10	1010	1010	Reserved	11	1011	1011	12	1100	1100	13	1101	1101	14	1110	1110	15	1111	1111
	No.	VGHS1.3-0 VGHS2.3-0	VGH (V) VGHS(V)	VGLS.3-0	VGL (V)																																																																																		
	0	0000	12.541	0000	-8.484																																																																																		
	1	0001	12.889	0001	-8.773																																																																																		
	2	0010	13.257	0010	-9.078																																																																																		
	3	0011	13.647	0011	-9.400																																																																																		
	4	0100	14.061	0100	-9.741																																																																																		
	5	0101	14.500	0101	-10.103																																																																																		
	6	0110	14.968	0110	-10.488																																																																																		
	7	0111	15.467	0111	-10.897																																																																																		
	8	1000	16.000	1000	-11.333																																																																																		
	9	1001	Reserved	1001	-11.800																																																																																		
	10	1010		1010	Reserved																																																																																		
	11	1011		1011																																																																																			
	12	1100		1100																																																																																			
	13	1101		1101																																																																																			
	14	1110		1110																																																																																			
15	1111	1111																																																																																					

No.	VPMS.3-0	AVDD(V)	VNMS.3-0	AVEE(V)
0	0000	5.691	0000	-3.170
1	0001	5.775	0001	-3.250
2	0010	5.860	0010	-3.324
3	0011	5.947	0011	-3.400
4	0100	6.003	0100	-3.466
5	0101	6.129	0101	-3.542
6	0110	6.225	0110	-3.620
7	0111	6.323	0111	-3.701
8	1000	6.425	1000	-3.784
9	1001	6.535	1001	-3.869
10	1010	6.666	1010	-3.957
11	1011	6.756	1011	-4.047
12	1100	6.872	1100	-4.141
13	1101	6.993	1101	-4.237
14	1110	7.532	1110	-4.336
15	1111	7.678	1111	-4.439

Description -VRH.5-0: VOP voltage level selection. VCOM.6-0=00h

No.	VRH. 5-0	VOP	No.	VRH. 5-0	VOP
0	000000	3.650	32	100000	5.250
1	000001	3.700	33	100001	5.300
2	000010	3.750	34	100010	5.350
3	000011	3.800	35	100011	5.400
4	000100	3.850	36	100100	5.450
5	000101	3.900	37	100101	5.500
6	000110	3.950	38	100110	Reserved
7	000111	4.000	39	100111	
8	001000	4.050	40	101000	
9	001001	4.100	41	101001	
10	001010	4.150	42	101010	
11	001011	4.200	43	101011	
12	001100	4.250	44	101100	
13	001101	4.300	45	101101	
14	001110	4.350	46	101110	
15	001111	4.400	47	101111	
16	010000	4.450	48	110000	
17	010001	4.500	49	110001	
18	010010	4.550	50	110010	
19	010011	4.600	51	110011	
20	010100	4.650	52	110100	
21	010101	4.700	53	110101	
22	010110	4.750	54	110110	
23	010111	4.800	55	110111	
24	011000	4.850	56	111000	
25	011001	4.900	57	111001	
26	011010	4.950	58	111010	
27	011011	5.000	59	111011	
28	011100	5.050	60	111100	
29	011101	5.100	61	111101	
30	011110	5.150	62	111110	
31	011111	5.200	63	111111	

Register availability	<table border="1"> <thead> <tr> <th>Status</th> <th>Availability</th> </tr> </thead> <tbody> <tr> <td>Normal Mode On, Idle Mode Off, Sleep Out</td> <td>Yes</td> </tr> <tr> <td>Normal Mode On, Idle Mode On, Sleep Out</td> <td>Yes</td> </tr> <tr> <td>Partial Mode On, Idle Mode Off, Sleep Out</td> <td>Yes</td> </tr> <tr> <td>Partial Mode On, Idle Mode On, Sleep Out</td> <td>Yes</td> </tr> <tr> <td>Sleep In</td> <td>Yes</td> </tr> </tbody> </table>		Status	Availability	Normal Mode On, Idle Mode Off, Sleep Out	Yes	Normal Mode On, Idle Mode On, Sleep Out	Yes	Partial Mode On, Idle Mode Off, Sleep Out	Yes	Partial Mode On, Idle Mode On, Sleep Out	Yes	Sleep In	Yes
	Status	Availability												
	Normal Mode On, Idle Mode Off, Sleep Out	Yes												
	Normal Mode On, Idle Mode On, Sleep Out	Yes												
	Partial Mode On, Idle Mode Off, Sleep Out	Yes												
	Partial Mode On, Idle Mode On, Sleep Out	Yes												
Sleep In	Yes													
Default	<table border="1"> <thead> <tr> <th>Status</th> <th>Default Value</th> </tr> </thead> <tbody> <tr> <td>Power On Sequence</td> <td>00h</td> </tr> <tr> <td>S/W Reset</td> <td>00h</td> </tr> <tr> <td>H/W Reset</td> <td>00h</td> </tr> </tbody> </table>		Status	Default Value	Power On Sequence	00h	S/W Reset	00h	H/W Reset	00h				
	Status	Default Value												
	Power On Sequence	00h												
	S/W Reset	00h												
H/W Reset	00h													

● PWR2 (C2h): Power Control 2

C2H	Power Control 2												
Inst / Para	D/CX	WRX	RDX	D17-8	D7	D6	D5	D4	D3	D2	D1	D0	HEX
PWR2	0	↑	1	-	1	1	0	0	0	0	1	0	(C2h)
1 st parameter	1	↑	1	-	VGHS2_B.3-0				VGHS1_B.3-0				(44h)
2 nd parameter	1	↑	1	-	-	-	-	-	VGLS_B.3-0				(06h)
3 rd parameter	1	↑	1	-	VPMS_B.3-0				VNMS_B.3-0				(Ach)
4 th parameter	1	↑	1	-	-	-	VRH_B.5-0						(1Bh)
<p>-C2h Function for Idle mode</p> <p>-VGHS1.3-0: STEP2 VGH voltage level selection.</p> <p>-VGHS2.3-0: STEP2S VGHS voltage level selection.</p> <p>-VGLS.3-0: STEP3 VGL voltage level selection.</p>													

Description

No.	VGHS _{1.3-0} VGHS _{2.3-0}	VGH (V) VGHS(V)	VGLS ₃₋₀	VGL (V)
0	0000	12.541	0000	-8.484
1	0001	12.889	0001	-8.773
2	0010	13.257	0010	-9.078
3	0011	13.647	0011	-9.400
4	0100	14.061	0100	-9.741
5	0101	14.500	0101	-10.103
6	0110	14.968	0110	-10.488
7	0111	15.467	0111	-10.897
8	1000	16.000	1000	-11.333
9	1001	Reserved	1001	-11.800
10	1010		1010	Reserved
11	1011		1011	
12	1100		1100	
13	1101		1101	
14	1110		1110	
15	1111		1111	

-VPMS.3-0: STEP1 AVDD voltage level selection.

-VNMS.3-0: STEP4 AVEE voltage level selection.

Description

No.	VPMS ₃₋₀	AVDD(V)	VNMS ₃₋₀	AVEE(V)
0	0000	5.691	0000	-3.170
1	0001	5.775	0001	-3.250
2	0010	5.860	0010	-3.324
3	0011	5.947	0011	-3.400
4	0100	6.003	0100	-3.466
5	0101	6.129	0101	-3.542
6	0110	6.225	0110	-3.620
7	0111	6.323	0111	-3.701
8	1000	6.425	1000	-3.784
9	1001	6.535	1001	-3.869
10	1010	6.666	1010	-3.957
11	1011	6.756	1011	-4.047
12	1100	6.872	1100	-4.141
13	1101	6.993	1101	-4.237
14	1110	7.532	1110	-4.336
15	1111	7.678	1111	-4.439

-VRH.5-0: VOP voltage level selection. VCOM.6-0=00h

No.	VRH. 5-0	VOP	No.	VRH. 5-0	VOP
0	000000	3.650	32	100000	5.250
1	000001	3.700	33	100001	5.300
2	000010	3.750	34	100010	5.350
3	000011	3.800	35	100011	5.400
4	000100	3.850	36	100100	5.450
5	000101	3.900	37	100101	5.500
6	000110	3.950	38	100110	Reserved
7	000111	4.000	39	100111	
8	001000	4.050	40	101000	
9	001001	4.100	41	101001	
10	001010	4.150	42	101010	
11	001011	4.200	43	101011	
12	001100	4.250	44	101100	
13	001101	4.300	45	101101	
14	001110	4.350	46	101110	
15	001111	4.400	47	101111	
16	010000	4.450	48	110000	
17	010001	4.500	49	110001	
18	010010	4.550	50	110010	
19	010011	4.600	51	110011	
20	010100	4.650	52	110100	
21	010101	4.700	53	110101	
22	010110	4.750	54	110110	
23	010111	4.800	55	110111	
24	011000	4.850	56	111000	
25	011001	4.900	57	111001	
26	011010	4.950	58	111010	
27	011011	5.000	59	111011	
28	011100	5.050	60	111100	
29	011101	5.100	61	111101	
30	011110	5.150	62	111110	
31	011111	5.200	63	111111	

Register availability

Status	Availability
Normal Mode On, Idle Mode Off, Sleep Out	Yes
Normal Mode On, Idle Mode On, Sleep Out	Yes
Partial Mode On, Idle Mode Off, Sleep Out	Yes
Partial Mode On, Idle Mode On, Sleep Out	Yes
Sleep In	Yes

Default

Status	Default Value
Power On Sequence	00h
S/W Reset	00h
H/W Reset	00h

● PWR3 (C3h): Power Control 3

C3H	Power Control 3												HEX																																																																			
Inst / Para	D/CX	WRX	RDX	D17-8	D7	D6	D5	D4	D3	D2	D1	D0	HEX																																																																			
PWR2	0	↑	1	-	1	1	0	0	0	0	1	1	(C3h)																																																																			
1 st parameter	1	↑	1	-	S2DC2_A.2-0			S2DC1_A.2-0			(42h)																																																																					
2 nd parameter	1	↑	1	-	-	-	S3DC_A.2-0			(02h)																																																																						
3 rd parameter	1	↑	1	-	S1DC_A.2-0			S4DC_A.2-0			(24h)																																																																					
4 th parameter	1	↑	1	-	-	-	AP_A.2-0			(03h)																																																																						
Description	<p>-S1DC.3-0: Set clock operation frequency for AVDD. -S4DC.3-0: Set clock operation frequency for AVEE. -S2DC1.3-0: Set clock operation frequency for VGH. -S2DC2.3-0: Set clock operation frequency for VGHS. -S3DC.3-0: Set clock operation frequency for VGL.</p> <table border="1"> <thead> <tr> <th colspan="3">Base frequency fBCLK (MHz) =</th> <th>20</th> </tr> <tr> <th>No.</th> <th>S1DC.2-0 S4DC.2-0 S2DC1.2-0 S2DC2.2-0 S3DC.2-0</th> <th>Divided by</th> <th>MHz</th> </tr> </thead> <tbody> <tr><td>0</td><td>0000</td><td>4</td><td>5.00</td></tr> <tr><td>1</td><td>0001</td><td>6</td><td>3.33</td></tr> <tr><td>2</td><td>0010</td><td>8</td><td>2.50</td></tr> <tr><td>3</td><td>0011</td><td>10</td><td>2.00</td></tr> <tr><td>4</td><td>0100</td><td>16</td><td>1.25</td></tr> <tr><td>5</td><td>0101</td><td>20</td><td>1.00</td></tr> <tr><td>6</td><td>0110</td><td>24</td><td>0.83</td></tr> <tr><td>7</td><td>0111</td><td>32</td><td>0.63</td></tr> </tbody> </table> <p>AP.2-0: Current setting to gamma OP circuit.</p> <table border="1"> <thead> <tr> <th>No.</th> <th>AP.2-0</th> <th>Current level</th> </tr> </thead> <tbody> <tr><td>0</td><td>000</td><td>Operation stop</td></tr> <tr><td>1</td><td>001</td><td>strength 0 (lowest)</td></tr> <tr><td>2</td><td>010</td><td>strength 1</td></tr> <tr><td>3</td><td>011</td><td>strength 2</td></tr> <tr><td>4</td><td>100</td><td>strength 3</td></tr> <tr><td>5</td><td>101</td><td>strength 4</td></tr> <tr><td>6</td><td>110</td><td>strength 5</td></tr> <tr><td>7</td><td>111</td><td>strength 6 (highest)</td></tr> </tbody> </table>													Base frequency fBCLK (MHz) =			20	No.	S1DC.2-0 S4DC.2-0 S2DC1.2-0 S2DC2.2-0 S3DC.2-0	Divided by	MHz	0	0000	4	5.00	1	0001	6	3.33	2	0010	8	2.50	3	0011	10	2.00	4	0100	16	1.25	5	0101	20	1.00	6	0110	24	0.83	7	0111	32	0.63	No.	AP.2-0	Current level	0	000	Operation stop	1	001	strength 0 (lowest)	2	010	strength 1	3	011	strength 2	4	100	strength 3	5	101	strength 4	6	110	strength 5	7	111	strength 6 (highest)
	Base frequency fBCLK (MHz) =			20																																																																												
	No.	S1DC.2-0 S4DC.2-0 S2DC1.2-0 S2DC2.2-0 S3DC.2-0	Divided by	MHz																																																																												
	0	0000	4	5.00																																																																												
	1	0001	6	3.33																																																																												
	2	0010	8	2.50																																																																												
	3	0011	10	2.00																																																																												
	4	0100	16	1.25																																																																												
	5	0101	20	1.00																																																																												
	6	0110	24	0.83																																																																												
7	0111	32	0.63																																																																													
No.	AP.2-0	Current level																																																																														
0	000	Operation stop																																																																														
1	001	strength 0 (lowest)																																																																														
2	010	strength 1																																																																														
3	011	strength 2																																																																														
4	100	strength 3																																																																														
5	101	strength 4																																																																														
6	110	strength 5																																																																														
7	111	strength 6 (highest)																																																																														

Register availability	<table border="1"> <thead> <tr> <th>Status</th> <th>Availability</th> </tr> </thead> <tbody> <tr> <td>Normal Mode On, Idle Mode Off, Sleep Out</td> <td>Yes</td> </tr> <tr> <td>Normal Mode On, Idle Mode On, Sleep Out</td> <td>Yes</td> </tr> <tr> <td>Partial Mode On, Idle Mode Off, Sleep Out</td> <td>Yes</td> </tr> <tr> <td>Partial Mode On, Idle Mode On, Sleep Out</td> <td>Yes</td> </tr> <tr> <td>Sleep In</td> <td>Yes</td> </tr> </tbody> </table>		Status	Availability	Normal Mode On, Idle Mode Off, Sleep Out	Yes	Normal Mode On, Idle Mode On, Sleep Out	Yes	Partial Mode On, Idle Mode Off, Sleep Out	Yes	Partial Mode On, Idle Mode On, Sleep Out	Yes	Sleep In	Yes
	Status	Availability												
	Normal Mode On, Idle Mode Off, Sleep Out	Yes												
	Normal Mode On, Idle Mode On, Sleep Out	Yes												
	Partial Mode On, Idle Mode Off, Sleep Out	Yes												
	Partial Mode On, Idle Mode On, Sleep Out	Yes												
Sleep In	Yes													
Default	<table border="1"> <thead> <tr> <th>Status</th> <th>Default Value</th> </tr> </thead> <tbody> <tr> <td>Power On Sequence</td> <td>N/A</td> </tr> <tr> <td>S/W Reset</td> <td>N/A</td> </tr> <tr> <td>H/W Reset</td> <td>N/A</td> </tr> </tbody> </table>		Status	Default Value	Power On Sequence	N/A	S/W Reset	N/A	H/W Reset	N/A				
	Status	Default Value												
	Power On Sequence	N/A												
	S/W Reset	N/A												
H/W Reset	N/A													

● VCOMCTL (C5h): Vcom Control

C5H	Vcom Control																		
Inst / Para	D/CX	WRX	RDX	D17-8	D7	D6	D5	D4	D3	D2	D1	D0	HEX						
VCOMCTL	0	↑	1	-	1	1	0	0	0	1	0	1	(C5h)						
parameter	1	↑	1	-	VMF_MODE	VCOM.6-0							(57h)						
parameter	1	↑	1	-	VMFS_MODE	-	-	-	-	-	-	-	(00h)						
Description	- VCM=VCOM.6-0 + VMFOFST.6-0																		
						<table border="1"> <thead> <tr> <th>Status</th> <th>VMFOFST Selector (Cmd0xD6, Cmd0xD7)</th> </tr> </thead> <tbody> <tr> <td>Cmd0x36, ML=0</td> <td>VMF1.6-0</td> </tr> <tr> <td>Cmd0x36, ML=1</td> <td>VMF2.6-0</td> </tr> </tbody> </table>		Status	VMFOFST Selector (Cmd0xD6, Cmd0xD7)	Cmd0x36, ML=0	VMF1.6-0	Cmd0x36, ML=1	VMF2.6-0						
	Status	VMFOFST Selector (Cmd0xD6, Cmd0xD7)																	
	Cmd0x36, ML=0	VMF1.6-0																	
	Cmd0x36, ML=1	VMF2.6-0																	
-VMF_MODE: To control gamma VSF voltage level selection.																			
		<table border="1"> <thead> <tr> <th>VMF_MODE</th> <th>Description</th> </tr> </thead> <tbody> <tr> <td>0</td> <td>VMF1.6-0/VMF2.6-0 will be valued copied from OTP.</td> </tr> <tr> <td>1</td> <td>VMF1.6-0/VMF2.6-0 will be valued provided by users.</td> </tr> </tbody> </table>											VMF_MODE	Description	0	VMF1.6-0/VMF2.6-0 will be valued copied from OTP.	1	VMF1.6-0/VMF2.6-0 will be valued provided by users.	
VMF_MODE	Description																		
0	VMF1.6-0/VMF2.6-0 will be valued copied from OTP.																		
1	VMF1.6-0/VMF2.6-0 will be valued provided by users.																		
-VMFS_MODE:																			
		<table border="1"> <thead> <tr> <th>VMFS_MODE</th> <th>Description</th> </tr> </thead> <tbody> <tr> <td>0</td> <td>VMF1 & VMF2 must be alternated by ML (Cmdox36.Po.D4) bit</td> </tr> <tr> <td>1</td> <td>Uses VMF1</td> </tr> </tbody> </table>											VMFS_MODE	Description	0	VMF1 & VMF2 must be alternated by ML (Cmdox36.Po.D4) bit	1	Uses VMF1	
VMFS_MODE	Description																		
0	VMF1 & VMF2 must be alternated by ML (Cmdox36.Po.D4) bit																		
1	Uses VMF1																		

-VCOM.6-0: To control gamma VSF voltage level selection.

No.	VCM[6:0]	VSF (V)	No.	VCM[6:0]	VSF (V)	No.	VCM[6:0]	VSF (V)	No.	VCM[6:0]	VSF (V)
0	0000000	0.000	32	0100000	0.000	64	1000000	0.625	96	1100000	1.425
1	0000001	0.000	33	0100001	0.000	65	1000001	0.650	97	1100001	1.450
2	0000010	0.000	34	0100010	0.000	66	1000010	0.675	98	1100010	1.475
3	0000011	0.000	35	0100011	0.000	67	1000011	0.700	99	1100011	1.500
4	0000100	0.000	36	0100100	0.000	68	1000100	0.725	100	1100100	1.525
5	0000101	0.000	37	0100101	0.000	69	1000101	0.750	101	1100101	1.550
6	0000110	0.000	38	0100110	0.000	70	1000110	0.775	102	1100110	1.575
7	0000111	0.000	39	0100111	0.000	71	1000111	0.800	103	1100111	1.600
8	0001000	0.000	40	0101000	0.025	72	1001000	0.825	104	1101000	1.625
9	0001001	0.000	41	0101001	0.050	73	1001001	0.850	105	1101001	1.650
10	0001010	0.000	42	0101010	0.075	74	1001010	0.875	106	1101010	1.675
11	0001011	0.000	43	0101011	0.100	75	1001011	0.900	107	1101011	1.700
12	0001100	0.000	44	0101100	0.125	76	1001100	0.925	108	1101100	1.725
13	0001101	0.000	45	0101101	0.150	77	1001101	0.950	109	1101101	1.750
14	0001110	0.000	46	0101110	0.175	78	1001110	0.975	110	1101110	1.775
15	0001111	0.000	47	0101111	0.200	79	1001111	1.000	111	1101111	1.800
16	0010000	0.000	48	0110000	0.225	80	1010000	1.025	112	1110000	1.825
17	0010001	0.000	49	0110001	0.250	81	1010001	1.050	113	1110001	1.850
18	0010010	0.000	50	0110010	0.275	82	1010010	1.075	114	1110010	1.875
19	0010011	0.000	51	0110011	0.300	83	1010011	1.100	115	1110011	1.900
20	0010100	0.000	52	0110100	0.325	84	1010100	1.125	116	1110100	1.925
21	0010101	0.000	53	0110101	0.350	85	1010101	1.150	117	1110101	1.950
22	0010110	0.000	54	0110110	0.375	86	1010110	1.175	118	1110110	1.975
23	0010111	0.000	55	0110111	0.400	87	1010111	1.200	119	1110111	2.000
24	0011000	0.000	56	0111000	0.425	88	1011000	1.225	120	1111000	2.025
25	0011001	0.000	57	0111001	0.450	89	1011001	1.250	121	1111001	2.050
26	0011010	0.000	58	0111010	0.475	90	1011010	1.275	122	1111010	2.075
27	0011011	0.000	59	0111011	0.500	91	1011011	1.300	123	1111011	2.100
28	0011100	0.000	60	0111100	0.525	92	1011100	1.325	124	1111100	2.125
29	0011101	0.000	61	0111101	0.550	93	1011101	1.350	125	1111101	2.150
30	0011110	0.000	62	0111110	0.575	94	1011110	1.375	126	1111110	2.175
31	0011111	0.000	63	0111111	0.600	95	1011111	1.400	127	1111111	2.200

Register availability

Status	Availability
Normal Mode On, Idle Mode Off, Sleep Out	Yes
Normal Mode On, Idle Mode On, Sleep Out	Yes
Partial Mode On, Idle Mode Off, Sleep Out	Yes
Partial Mode On, Idle Mode On, Sleep Out	Yes
Sleep In	Yes

Default

Status	Default Value
Power On Sequence	57h
S/W Reset	57h
H/W Reset	57h

● VMF1 Offset (D6h): Vcom1 Offset 1

D6H	Vcom Offset 1																																						
Inst / Para	D/CX	WRX	RDX	D17-8	D7	D6	D5	D4	D3	D2	D1	D0	HEX																										
PGC	0	↑	1	-	1	1	0	1	0	1	1	0	(D6h)																										
1 st parameter	1	↑	1	-		VMF1.6-0							(00h)																										
Description	VMF1.6-0, VMF2.6-0: to fine-tune an offset to VCOM.6-0 by user or from OTP.																																						
	<table border="1"> <thead> <tr> <th>VMF1.6-0/VMF2.6-0</th> <th>Offset</th> </tr> </thead> <tbody> <tr><td>0111111</td><td>+63</td></tr> <tr><td>0111110</td><td>+62</td></tr> <tr><td>:</td><td>:</td></tr> <tr><td>0000010</td><td>+2</td></tr> <tr><td>0000001</td><td>+1</td></tr> <tr><td>0000000</td><td>+0</td></tr> <tr><td>1111111</td><td>-1</td></tr> <tr><td>1111110</td><td>-2</td></tr> <tr><td>:</td><td>:</td></tr> <tr><td>1000010</td><td>-62</td></tr> <tr><td>1000001</td><td>-63</td></tr> <tr><td>1000000</td><td>-64</td></tr> </tbody> </table>													VMF1.6-0/VMF2.6-0	Offset	0111111	+63	0111110	+62	:	:	0000010	+2	0000001	+1	0000000	+0	1111111	-1	1111110	-2	:	:	1000010	-62	1000001	-63	1000000	-64
	VMF1.6-0/VMF2.6-0	Offset																																					
	0111111	+63																																					
	0111110	+62																																					
	:	:																																					
	0000010	+2																																					
	0000001	+1																																					
	0000000	+0																																					
	1111111	-1																																					
	1111110	-2																																					
	:	:																																					
	1000010	-62																																					
	1000001	-63																																					
	1000000	-64																																					
Register availability	<table border="1"> <thead> <tr> <th>Status</th> <th>Availability</th> </tr> </thead> <tbody> <tr> <td>Normal Mode On, Idle Mode Off, Sleep Out</td> <td>Yes</td> </tr> <tr> <td>Normal Mode On, Idle Mode On, Sleep Out</td> <td>Yes</td> </tr> <tr> <td>Partial Mode On, Idle Mode Off, Sleep Out</td> <td>Yes</td> </tr> <tr> <td>Partial Mode On, Idle Mode On, Sleep Out</td> <td>Yes</td> </tr> <tr> <td>Sleep In</td> <td>Yes</td> </tr> </tbody> </table>													Status	Availability	Normal Mode On, Idle Mode Off, Sleep Out	Yes	Normal Mode On, Idle Mode On, Sleep Out	Yes	Partial Mode On, Idle Mode Off, Sleep Out	Yes	Partial Mode On, Idle Mode On, Sleep Out	Yes	Sleep In	Yes														
	Status	Availability																																					
	Normal Mode On, Idle Mode Off, Sleep Out	Yes																																					
	Normal Mode On, Idle Mode On, Sleep Out	Yes																																					
	Partial Mode On, Idle Mode Off, Sleep Out	Yes																																					
	Partial Mode On, Idle Mode On, Sleep Out	Yes																																					
Sleep In	Yes																																						
Default	<table border="1"> <thead> <tr> <th>Status</th> <th>Default Value</th> </tr> </thead> <tbody> <tr> <td>Power On Sequence</td> <td>00h</td> </tr> <tr> <td>S/W Reset</td> <td>00h</td> </tr> <tr> <td>H/W Reset</td> <td>00h</td> </tr> </tbody> </table>													Status	Default Value	Power On Sequence	00h	S/W Reset	00h	H/W Reset	00h																		
	Status	Default Value																																					
	Power On Sequence	00h																																					
	S/W Reset	00h																																					
H/W Reset	00h																																						

● VMF2 Offset (D7h): Vcom Offset 2

D7H	Vcom Offset 2																																					
Inst / Para	D/CX	WRX	RDX	D17-8	D7	D6	D5	D4	D3	D2	D1	D0	HEX																									
PGC	0	↑	1	-	1	1	0	1	1	1	1	0	(D7h)																									
1 st parameter	1	↑	1	-		VMF2.6-0							(00h)																									
Description	VMF2.6-0: to fine-tune an offset to VCOM.6-0 by user or from OTP.																																					
	<table border="1"> <thead> <tr> <th>VMF1.6-0/VMF2.6-0</th> <th>Offset</th> </tr> </thead> <tbody> <tr><td>01111111</td><td>+63</td></tr> <tr><td>01111110</td><td>+62</td></tr> <tr><td>:</td><td>:</td></tr> <tr><td>0000010</td><td>+2</td></tr> <tr><td>0000001</td><td>+1</td></tr> <tr><td>0000000</td><td>+0</td></tr> <tr><td>11111111</td><td>-1</td></tr> <tr><td>11111110</td><td>-2</td></tr> <tr><td>:</td><td>:</td></tr> <tr><td>1000010</td><td>-62</td></tr> <tr><td>1000001</td><td>-63</td></tr> <tr><td>1000000</td><td>-64</td></tr> </tbody> </table>													VMF1.6-0/VMF2.6-0	Offset	01111111	+63	01111110	+62	:	:	0000010	+2	0000001	+1	0000000	+0	11111111	-1	11111110	-2	:	:	1000010	-62	1000001	-63	1000000
VMF1.6-0/VMF2.6-0	Offset																																					
01111111	+63																																					
01111110	+62																																					
:	:																																					
0000010	+2																																					
0000001	+1																																					
0000000	+0																																					
11111111	-1																																					
11111110	-2																																					
:	:																																					
1000010	-62																																					
1000001	-63																																					
1000000	-64																																					
Register availability	<table border="1"> <thead> <tr> <th>Status</th> <th>Availability</th> </tr> </thead> <tbody> <tr> <td>Normal Mode On, Idle Mode Off, Sleep Out</td> <td>Yes</td> </tr> <tr> <td>Normal Mode On, Idle Mode On, Sleep Out</td> <td>Yes</td> </tr> <tr> <td>Partial Mode On, Idle Mode Off, Sleep Out</td> <td>Yes</td> </tr> <tr> <td>Partial Mode On, Idle Mode On, Sleep Out</td> <td>Yes</td> </tr> <tr> <td>Sleep In</td> <td>Yes</td> </tr> </tbody> </table>													Status	Availability	Normal Mode On, Idle Mode Off, Sleep Out	Yes	Normal Mode On, Idle Mode On, Sleep Out	Yes	Partial Mode On, Idle Mode Off, Sleep Out	Yes	Partial Mode On, Idle Mode On, Sleep Out	Yes	Sleep In	Yes													
	Status	Availability																																				
	Normal Mode On, Idle Mode Off, Sleep Out	Yes																																				
	Normal Mode On, Idle Mode On, Sleep Out	Yes																																				
	Partial Mode On, Idle Mode Off, Sleep Out	Yes																																				
	Partial Mode On, Idle Mode On, Sleep Out	Yes																																				
Sleep In	Yes																																					
Default	<table border="1"> <thead> <tr> <th>Status</th> <th>Default Value</th> </tr> </thead> <tbody> <tr> <td>Power On Sequence</td> <td>00h</td> </tr> <tr> <td>S/W Reset</td> <td>00h</td> </tr> <tr> <td>H/W Reset</td> <td>00h</td> </tr> </tbody> </table>													Status	Default Value	Power On Sequence	00h	S/W Reset	00h	H/W Reset	00h																	
	Status	Default Value																																				
	Power On Sequence	00h																																				
	S/W Reset	00h																																				
H/W Reset	00h																																					

● PGC (E0h): Positive Gamma Control

E0H	Positive Gamma Control												
Inst / Para	D/CX	WRX	RDX	D17-8	D7	D6	D5	D4	D3	D2	D1	D0	HEX
PGC	0	↑	1	-	1	1	1	0	0	0	0	0	(E0h)
1 st parameter	1	↑	1	-	VC63P.3-0				VC0P.3-0				(F0h)
2 nd parameter	1	↑	1	-	-	-	VC1P.5-0						(03h)
3 rd parameter	1	↑	1	-	-	-	VC2P.5-0						(05h)
4 th parameter	1	↑	1	-	-	-	-	VC4P.4-0					(09h)
5 th parameter	1	↑	1	-	-	-	-	VC6P.4-0					(0Ch)
6 th parameter	1	↑	1	-	-	VJ0P.2-0			VC13P.3-0				(0Fh)
7 th parameter	1	↑	1	-	-	VC20P.6-0							(3Eh)
8 th parameter	1	↑	1	-	-	VC36P.2-0			-	VC27P.2-0			(77h)
9 th parameter	1	↑	1	-	-	VC43P.6-0							(4Fh)
10 th parameter	1	↑	1	-	-	VJ1P.2-0			VC50P.3-0				(0Fh)
11 th parameter	1	↑	1	-	-	-	-	VC57P.4-0					(17h)
12 th parameter	1	↑	1	-	-	-	-	VC59P.4-0					(17h)
13 th parameter	1	↑	1	-	-	-	-	VC61P.5-0					(21h)
14 th parameter	1	↑	1	-	-	-	-	VC62P.5-0					(23h)
Description	- Adjust the gamma characteristics of the TFT panel. Positive Gamma Control '-': Don't care.												
Register availability			Status					Availability					
			Normal Mode On, Idle Mode Off, Sleep Out					Yes					
			Normal Mode On, Idle Mode On, Sleep Out					Yes					
			Partial Mode On, Idle Mode Off, Sleep Out					Yes					
			Partial Mode On, Idle Mode On, Sleep Out					Yes					
			Sleep In					Yes					
Default	Status					Default Value							
	Power On Sequence					N/A							
	S/W Reset					N/A							
	H/W Reset					N/A							

● NGC (E1h): Negative Gamma Control

E0H	Positive Gamma Control																								
	Inst / Para	D/CX	WRX	RDX	D17-8	D7	D6	D5	D4	D3	D2	D1	D0	HEX											
PGC	0	↑	1	-	1	1	1	0	0	0	0	0	0	(E0h)											
1 st parameter	1	↑	1	-	VC63N.3-0				VC0N.3-0				(F0h)												
2 nd parameter	1	↑	1	-	-	-	VC1N.5-0						(03h)												
3 rd parameter	1	↑	1	-	-	-	VC2N.5-0						(05h)												
4 th parameter	1	↑	1	-	-	-	-	VC4N.4-0					(09h)												
5 th parameter	1	↑	1	-	-	-	-	VC6N.4-0					(0Ch)												
6 th parameter	1	↑	1	-	-	VJ0N.2-0			VC13N.3-0				(0Fh)												
7 th parameter	1	↑	1	-	-	VC20N.6-0							(3Eh)												
8 th parameter	1	↑	1	-	-	VC36N.2-0			-	VC27N.2-0			(77h)												
9 th parameter	1	↑	1	-	-	VC43N.6-0							(4Fh)												
10 th parameter	1	↑	1	-	-	VJ1N.2-0			VC50N.3-0				(0Fh)												
11 th parameter	1	↑	1	-	-	-	-	VC57N.4-0					(17h)												
12 th parameter	1	↑	1	-	-	-	-	VC59N.4-0					(17h)												
13 th parameter	1	↑	1	-	-	-	-	VC61N.5-0					(21h)												
14 th parameter	1	↑	1	-	-	-	-	VC62N.5-0					(23h)												
Description	- Adjust the gamma characteristics of the TFT panel. Positive Gamma Control '-': Don't care.																								
Register availability	<table border="1"> <thead> <tr> <th>Status</th> <th>Availability</th> </tr> </thead> <tbody> <tr> <td>Normal Mode On, Idle Mode Off, Sleep Out</td> <td>Yes</td> </tr> <tr> <td>Normal Mode On, Idle Mode On, Sleep Out</td> <td>Yes</td> </tr> <tr> <td>Partial Mode On, Idle Mode Off, Sleep Out</td> <td>Yes</td> </tr> <tr> <td>Partial Mode On, Idle Mode On, Sleep Out</td> <td>Yes</td> </tr> <tr> <td>Sleep In</td> <td>Yes</td> </tr> </tbody> </table>													Status	Availability	Normal Mode On, Idle Mode Off, Sleep Out	Yes	Normal Mode On, Idle Mode On, Sleep Out	Yes	Partial Mode On, Idle Mode Off, Sleep Out	Yes	Partial Mode On, Idle Mode On, Sleep Out	Yes	Sleep In	Yes
Status	Availability																								
Normal Mode On, Idle Mode Off, Sleep Out	Yes																								
Normal Mode On, Idle Mode On, Sleep Out	Yes																								
Partial Mode On, Idle Mode Off, Sleep Out	Yes																								
Partial Mode On, Idle Mode On, Sleep Out	Yes																								
Sleep In	Yes																								
Default	<table border="1"> <thead> <tr> <th>Status</th> <th>Default Value</th> </tr> </thead> <tbody> <tr> <td>Power On Sequence</td> <td>N/A</td> </tr> <tr> <td>S/W Reset</td> <td>N/A</td> </tr> <tr> <td>H/W Reset</td> <td>N/A</td> </tr> </tbody> </table>													Status	Default Value	Power On Sequence	N/A	S/W Reset	N/A	H/W Reset	N/A				
Status	Default Value																								
Power On Sequence	N/A																								
S/W Reset	N/A																								
H/W Reset	N/A																								

● ANAMODE (E5h): Analog System Control

E5H	Analog System Control												HEX																																																																				
Inst / Para	D/CX	WRX	RDX	D17-8	D7	D6	D5	D4	D3	D2	D1	D0																																																																					
PGC	0	↑	1	-	1	1	1	0	0	1	0	1	(E5h)																																																																				
1 st parameter	1	↑	1	-	GVDD_AD_A.3-0			GVEE_AD_A.3-0					(9Ah)																																																																				
2 nd parameter	1	↑	1	-	1	1	1	1	0	1	0	1	(F5h)																																																																				
3 rd parameter	1	↑	1	-	SVDD_SEL_A.3-0			SVEE_SEL_A.3-0					(95h)																																																																				
4 th parameter	1	↑	1	-	0	0	1	1	0	1	0	0	(34h)																																																																				
5 th parameter	1	↑	1	-	0	0	1	0	0	0	1	0	(22h)																																																																				
6 th parameter	1	↑	1	-	0	0	1	0	0	1	0	1	(25h)																																																																				
7 th parameter	1	↑	1	-	0	0	0	1	0	0	0	VDDSBYPASS	(11h)																																																																				
8 th parameter	1	↑	1	-	-	ICN1_B.3-1			-	ICP1_B.3-1			(22h)																																																																				
9 th parameter	1	↑	1	-	-	ICN2_B.3-1			-	ICP2_B.3-1			(22h)																																																																				
10 th parameter	1	↑	1	-	-	ICN3_B.3-1			-	ICP3_B.3-1			(22h)																																																																				
11 th parameter	1	↑	1	-	-	ICN4_B.3-1			-	ICP4_B.3-1			(22h)																																																																				
12 th parameter	1	↑	1	-	-	ICN5_B.3-1			-	ICP5_B.3-1			(22h)																																																																				
13 th parameter	1	↑	1	-	-	ICN6_B.3-1			-	ICP6_B.3-1			(22h)																																																																				
14 th parameter	1	↑	1	-	-	ICN7_B.3-1			-	ICP7_B.3-1			(22h)																																																																				
Description	-GVDD_AD.3-0: To set gamma system GVDD voltage level.																																																																																
	-GVEE_AD.3-0: To set gamma system GVEE voltage level.																																																																																
	<table border="1"> <thead> <tr> <th>No.</th> <th>GVDD_AD.3-0 GVEE_AD.3-0</th> <th>GVDD(V)</th> <th>GVEE(V)</th> </tr> </thead> <tbody> <tr><td>0</td><td>0000</td><td>5.502</td><td>-4.902</td></tr> <tr><td>1</td><td>0001</td><td>5.602</td><td>-4.702</td></tr> <tr><td>2</td><td>0010</td><td>5.702</td><td>-3.202</td></tr> <tr><td>3</td><td>0011</td><td>5.802</td><td>-3.302</td></tr> <tr><td>4</td><td>0100</td><td>5.902</td><td>-3.402</td></tr> <tr><td>5</td><td>0101</td><td>6.002</td><td>-3.502</td></tr> <tr><td>6</td><td>0110</td><td>6.102</td><td>-3.602</td></tr> <tr><td>7</td><td>0111</td><td>6.202</td><td>-3.702</td></tr> <tr><td>8</td><td>1000</td><td>6.302</td><td>-3.802</td></tr> <tr><td>9</td><td>1001</td><td>6.402</td><td>-3.902</td></tr> <tr><td>10</td><td>1010</td><td>6.502</td><td>-4.002</td></tr> <tr><td>11</td><td>1011</td><td>6.602</td><td>-4.102</td></tr> <tr><td>12</td><td>1100</td><td>6.702</td><td>-4.202</td></tr> <tr><td>13</td><td>1101</td><td>6.802</td><td>-4.302</td></tr> <tr><td>14</td><td>1110</td><td>6.902</td><td>-4.402</td></tr> <tr><td>15</td><td>1111</td><td>7.002</td><td>-4.502</td></tr> </tbody> </table>													No.	GVDD_AD.3-0 GVEE_AD.3-0	GVDD(V)	GVEE(V)	0	0000	5.502	-4.902	1	0001	5.602	-4.702	2	0010	5.702	-3.202	3	0011	5.802	-3.302	4	0100	5.902	-3.402	5	0101	6.002	-3.502	6	0110	6.102	-3.602	7	0111	6.202	-3.702	8	1000	6.302	-3.802	9	1001	6.402	-3.902	10	1010	6.502	-4.002	11	1011	6.602	-4.102	12	1100	6.702	-4.202	13	1101	6.802	-4.302	14	1110	6.902	-4.402	15	1111	7.002	-4.502
	No.	GVDD_AD.3-0 GVEE_AD.3-0	GVDD(V)	GVEE(V)																																																																													
	0	0000	5.502	-4.902																																																																													
	1	0001	5.602	-4.702																																																																													
	2	0010	5.702	-3.202																																																																													
	3	0011	5.802	-3.302																																																																													
	4	0100	5.902	-3.402																																																																													
	5	0101	6.002	-3.502																																																																													
	6	0110	6.102	-3.602																																																																													
	7	0111	6.202	-3.702																																																																													
	8	1000	6.302	-3.802																																																																													
	9	1001	6.402	-3.902																																																																													
	10	1010	6.502	-4.002																																																																													
	11	1011	6.602	-4.102																																																																													
12	1100	6.702	-4.202																																																																														
13	1101	6.802	-4.302																																																																														
14	1110	6.902	-4.402																																																																														
15	1111	7.002	-4.502																																																																														
ICPx.2-0: Set positive source OP bias current. Where, x=1~7. (Max=7)																																																																																	
ICNx.2-0: Set negative source OP bias current. Where, x=1~7. (Max=7)																																																																																	

- SVDD_SEL.3-0: To set source OP SVDD voltage level.
 - SVEE_SEL.3-0: To set source OP SVEE voltage level.

No.	SVDD_SEL.3-0 SVEE_SEL.3-0	SVDD(V)	SVEE(V)
0	0000	5.400	-4.400
1	0001	5.500	-4.300
2	0010	5.600	-4.200
3	0011	5.700	-4.100
4	0100	5.800	-4.000
5	0101	5.900	-3.900
6	0110	6.000	-3.800
7	0111	6.100	-3.700
8	1000	6.200	-3.600
9	1001	6.300	-3.500
10	1010	6.400	-3.400
11	1011	6.500	-3.300
12	1100	6.600	-3.200
13	1101	6.700	-3.100
14	1110	6.800	-4.800
15	1111	6.900	-5.000

-VDDSBYPASS: Internal VDDS regulator turn on or not. '1' to turn off while '0' to turn on. VDDS as voltage supply to internal OP.

VDDSBYPASS	Internal VDDS regulator On or Off?	VDDI voltage supply
0	On	1.65V~3.3V
1	Off	1.65V~1.95V, typically 1.8V

'-': Don't care.

Register availability

Status	Availability
Normal Mode On, Idle Mode Off, Sleep Out	Yes
Normal Mode On, Idle Mode On, Sleep Out	Yes
Partial Mode On, Idle Mode Off, Sleep Out	Yes
Partial Mode On, Idle Mode On, Sleep Out	Yes
Sleep In	Yes

Default

Status	Default Value
Power On Sequence	N/A
S/W Reset	N/A
H/W Reset	N/A

● DTRCON (D9h): Dithering Control

D9H	Dithering Control																								
Inst / Para	D/CX	WRX	RDX	D17-8	D7	D6	D5	D4	D3	D2	D1	D0	HEX												
PGC	0	↑	1	-	1	1	0	1	1	0	0	1	(D9h)												
1 st parameter	1	↑	1	-	EPF.1-0		EPFS	-	-	-	P24M.1-0		(00h)												
2 nd parameter	1	↑	1	-	CEPM.1-0		MG.1-0		MB.1-0		MR.1-0		(95h)												
Description	-EPF.1-0: 16bit-to-18-bit pixel format conversion rule.																								
	<table border="1"> <thead> <tr> <th>EPF.1-0</th> <th>Description</th> </tr> </thead> <tbody> <tr> <td>"00"</td> <td>R[0]=B[0]=0</td> </tr> <tr> <td>"01"</td> <td>R[0]=B[0]=1</td> </tr> <tr> <td>"10"</td> <td>R[0]=B[0]=MSB</td> </tr> <tr> <td>"11"</td> <td>R[0]=B[0]=G[0]</td> </tr> </tbody> </table> <p>EPFS: EPF function selection for case EPF.1-0 = "11". This bit takes no effect when EPF.1-0 = "00", "01" and "10". Setting this bit to '0' and EPF.1-0 = "11" -> R[0] = B[0] = G[0]. (Default setting) Setting this bit to '1' and EPF.1-0 = "11" -> conditional copy for R[0] and B[0].</p> <p>P24M.1-0: 24bpp color input mode. "00", truncation; "01", round; "1x" dithering. This parameter only take effect on 24bpp color input.</p> <p>CEPM.1-0: Color enhancement post-processing mode control: "00" truncation; "01": rounding; "10" dithering.</p> <p>MR.1-0, MG.1-0, MB.1-0: Bayer matrix rotation for RED, GREEN, BLUE sub-pixel. 0: 0 degree; 1: 90 degree; 2: 180 degree; 3: 270 degree.</p>													EPF.1-0	Description	"00"	R[0]=B[0]=0	"01"	R[0]=B[0]=1	"10"	R[0]=B[0]=MSB	"11"	R[0]=B[0]=G[0]		
EPF.1-0	Description																								
"00"	R[0]=B[0]=0																								
"01"	R[0]=B[0]=1																								
"10"	R[0]=B[0]=MSB																								
"11"	R[0]=B[0]=G[0]																								
Register availability	<table border="1"> <thead> <tr> <th>Status</th> <th>Availability</th> </tr> </thead> <tbody> <tr> <td>Normal Mode On, Idle Mode Off, Sleep Out</td> <td>Yes</td> </tr> <tr> <td>Normal Mode On, Idle Mode On, Sleep Out</td> <td>Yes</td> </tr> <tr> <td>Partial Mode On, Idle Mode Off, Sleep Out</td> <td>Yes</td> </tr> <tr> <td>Partial Mode On, Idle Mode On, Sleep Out</td> <td>Yes</td> </tr> <tr> <td>Sleep In</td> <td>Yes</td> </tr> </tbody> </table>													Status	Availability	Normal Mode On, Idle Mode Off, Sleep Out	Yes	Normal Mode On, Idle Mode On, Sleep Out	Yes	Partial Mode On, Idle Mode Off, Sleep Out	Yes	Partial Mode On, Idle Mode On, Sleep Out	Yes	Sleep In	Yes
	Status	Availability																							
	Normal Mode On, Idle Mode Off, Sleep Out	Yes																							
	Normal Mode On, Idle Mode On, Sleep Out	Yes																							
	Partial Mode On, Idle Mode Off, Sleep Out	Yes																							
	Partial Mode On, Idle Mode On, Sleep Out	Yes																							
Sleep In	Yes																								
Default	<table border="1"> <thead> <tr> <th>Status</th> <th>Default Value</th> </tr> </thead> <tbody> <tr> <td>Power On Sequence</td> <td>00h/95h</td> </tr> <tr> <td>S/W Reset</td> <td>00h/95h</td> </tr> <tr> <td>H/W Reset</td> <td>00h/95h</td> </tr> </tbody> </table>													Status	Default Value	Power On Sequence	00h/95h	S/W Reset	00h/95h	H/W Reset	00h/95h				
	Status	Default Value																							
	Power On Sequence	00h/95h																							
	S/W Reset	00h/95h																							
H/W Reset	00h/95h																								

● SRECON (DEh): SRE Control

DEH	SRE Control												
Inst / Para	D/CX	WRX	RDX	D17-8	D7	D6	D5	D4	D3	D2	D1	D0	HEX
SRECON	0	↑	1	-	1	1	0	1	1	1	1	0	(DEh)
1 st parameter	1	↑	1	-	DRK.5-0							(00h)	
2 nd parameter	1	↑	1	-	BRG.5-0							(00h)	
Description	<p>-DRK.5-0: Contrast gain control, ranged from -32 ~ +31, i.e -32/32 ~ +31/32 -> -1 ~ +0.96875.</p> <p>-BRG.5-0: A brightness offset added to an input pixel.ranged from -32 ~ +31, i.e -32/32 ~ +31/32 -> -1 ~ +0.96875.</p> <p>-Note that all 3 subpixels are added with the same value.</p> <p>‘-’: Don’t care.</p>												
Register availability	Status						Availability						
	Normal Mode On, Idle Mode Off, Sleep Out						Yes						
	Normal Mode On, Idle Mode On, Sleep Out						Yes						
	Partial Mode On, Idle Mode Off, Sleep Out						Yes						
	Partial Mode On, Idle Mode On, Sleep Out						Yes						
	Sleep In						Yes						
Default	Status						Default Value						
	Power On Sequence						00h						
	S/W Reset						00h						
	H/W Reset						00h						

● RLCMODE (C8h): Run-length Control

C8H	Run-length Control												HEX																		
Inst / Para	D/CX	WRX	RDX	D17-8	D7	D6	D5	D4	D3	D2	D1	D0	HEX																		
RLCMODE	0	↑	1	-	1	1	0	0	1	0	0	0	(C8h)																		
1 st parameter	1	↑	1	-	BDHM	PPBS	BLANKSEL	POLARITY	BWSM.1-0		CTRM.1-0		(0Ch)																		
2 nd parameter	1	↑	1	-					RBNRTH.3-0				(08h)																		
3 rd parameter	1	↑	1	-					GBNRTH.3-0				(08h)																		
4 th parameter	1	↑	1	-					BBNRTH.3-0				(08h)																		
5 th parameter	1	↑	1	-					RLC_EC.7-0				(00h)																		
Description	<p>-BDHM : Broken Display Handling Mode.</p> <p>“0”: Display immediately black when write pointer catch up with scan pointer.</p> <p>“1”: Display immediately black when write found.</p> <p>-PPBS: Ping-pong buffer mode selected or not. It determine the operation mode for Run-length Codec FIFO memory.</p> <p>“0”: A4KSRAM, which stacked by two 2K-byte SRAM blocks.</p> <p>“1”: PING-PONG by two 2K-byte SRAM blocks.</p> <p>-BLANKSEL: When write-over-scan or scan-over-write happen to FIFO, the decoded 1-bit pixel will be forced to the value specified by BLANKSEL.</p> <p>When the FIFO has no meaningful encoded data in it, the decoded output also forced to the value specified by BLANKSEL.</p> <p>“0”: Decoded 1-bit pixel forced to ‘0’.</p> <p>“1”: Decoded 1-bit pixel forced to ‘1’.</p> <p>-POLARITY: To determine if or not inverting the 1-bit pixel data, which binarized with RBNRTH.5-0, GBNRTH.5-0 and BBNRTH.5-0.</p> <p>“0”: 1-bit pixel data after binarized will not be inverted.</p> <p>“1”: 1-bit pixel data after binarized will be inverted.</p> <p>-BWSM.1-0: Option to adjust the bit width of the codeword.</p> <table border="1" data-bbox="327 1518 762 1697"> <thead> <tr> <th>BWSM.1-0</th> <th>Codeword Bit Width</th> </tr> </thead> <tbody> <tr> <td>00</td> <td>5 bits</td> </tr> <tr> <td>01</td> <td>6 bits</td> </tr> <tr> <td>10</td> <td>7 bits</td> </tr> <tr> <td>11</td> <td>8 bits</td> </tr> </tbody> </table> <p>-CTRM.1-0: Option for choosing the type of the code tree.</p> <table border="1" data-bbox="327 1758 750 1937"> <thead> <tr> <th>CTRM.1-0</th> <th>Code Tree Types</th> </tr> </thead> <tbody> <tr> <td>00</td> <td>weak white</td> </tr> <tr> <td>01</td> <td>balanced</td> </tr> <tr> <td>1X</td> <td>Only short-run</td> </tr> </tbody> </table> <p>-RBNRTH.5-0: Binarization threshold of Red-Color.</p>													BWSM.1-0	Codeword Bit Width	00	5 bits	01	6 bits	10	7 bits	11	8 bits	CTRM.1-0	Code Tree Types	00	weak white	01	balanced	1X	Only short-run
BWSM.1-0	Codeword Bit Width																														
00	5 bits																														
01	6 bits																														
10	7 bits																														
11	8 bits																														
CTRM.1-0	Code Tree Types																														
00	weak white																														
01	balanced																														
1X	Only short-run																														

	<p>-GBNRTH.5-0: Binarization threshold of Green-Color.</p> <p>-BBNRTH.5-0: Binarization threshold of Blue-Color.</p> <p>-RLC_EC.7-0: To initiate specific operation for RLC.</p> <table border="1"> <thead> <tr> <th>RLC_EC.7-0</th> <th>Description</th> </tr> </thead> <tbody> <tr> <td>0xA5</td> <td>To enable decoder test read function. Panel refresh operation will be stopped.</td> </tr> <tr> <td>0x5A</td> <td>To disable decoder test read function.</td> </tr> </tbody> </table> <p>⚠: Don't care.</p>	RLC_EC.7-0	Description	0xA5	To enable decoder test read function. Panel refresh operation will be stopped.	0x5A	To disable decoder test read function.		
RLC_EC.7-0	Description								
0xA5	To enable decoder test read function. Panel refresh operation will be stopped.								
0x5A	To disable decoder test read function.								
Register availability	<table border="1"> <thead> <tr> <th>Status</th> <th>Availability</th> </tr> </thead> <tbody> <tr> <td>Normal Mode On, Idle Mode Off, Sleep Out</td> <td>Yes</td> </tr> <tr> <td>Normal Mode On, Idle Mode On, Sleep Out</td> <td>Yes</td> </tr> <tr> <td>Sleep In</td> <td>Yes</td> </tr> </tbody> </table>	Status	Availability	Normal Mode On, Idle Mode Off, Sleep Out	Yes	Normal Mode On, Idle Mode On, Sleep Out	Yes	Sleep In	Yes
Status	Availability								
Normal Mode On, Idle Mode Off, Sleep Out	Yes								
Normal Mode On, Idle Mode On, Sleep Out	Yes								
Sleep In	Yes								
Default	<table border="1"> <thead> <tr> <th>Status</th> <th>Default Value</th> </tr> </thead> <tbody> <tr> <td>Power On Sequence</td> <td>00h</td> </tr> <tr> <td>S/W Reset</td> <td>00h</td> </tr> <tr> <td>H/W Reset</td> <td>00h</td> </tr> </tbody> </table>	Status	Default Value	Power On Sequence	00h	S/W Reset	00h	H/W Reset	00h
Status	Default Value								
Power On Sequence	00h								
S/W Reset	00h								
H/W Reset	00h								

Preliminary

● RGBIF (A0h): RGB Interface Control

A0H	SRE Control												HEX								
Inst / Para	D/CX	WRX	RDX	D17-8	D7	D6	D5	D4	D3	D2	D1	D0	HEX								
RGBIF	0	↑	1	-	1	0	1	0	0	0	0	0	(A0h)								
1 st parameter	1	↑	1	-	0	RCM	0	VSCP	HSCP	PKP	0	DEP	(01h)								
2 nd parameter	1	↑	1	-	RGBVBP.7-0							(06h)									
3 rd parameter	1	↑	1	-	RGBHBP.7-0							(06h)									
Description	<p>-RCM: RGB interface mode; 0: DE+SYNC mode; 1: SYNC mode.</p> <p>-VSCP: VSYNC polarity; 0: low sync, 1: high sync.</p> <p>-HSCP: HSYNC polarity; 0: low sync, 1: high sync.</p> <p>-PKP: PCLK polarity; 0: rising latch, 1: falling latch.</p> <p>-DEP: DE polarity; 0: high enable, 1: low enable.</p> <p>-RGBVBP.7-0: The number of lines in vertical back porch for SYNC mode.</p> <p>-RGBHBP.7-0: The number of dots in horizontal back porch for SYNC mode.</p> <p>‘-’: Don’t care.</p>																				
Register availability	<table border="1"> <thead> <tr> <th>Status</th> <th>Availability</th> </tr> </thead> <tbody> <tr> <td>Normal Mode On, Idle Mode Off, Sleep Out</td> <td>Yes</td> </tr> <tr> <td>Normal Mode On, Idle Mode On, Sleep Out</td> <td>Yes</td> </tr> <tr> <td>Sleep In</td> <td>Yes</td> </tr> </tbody> </table>													Status	Availability	Normal Mode On, Idle Mode Off, Sleep Out	Yes	Normal Mode On, Idle Mode On, Sleep Out	Yes	Sleep In	Yes
Status	Availability																				
Normal Mode On, Idle Mode Off, Sleep Out	Yes																				
Normal Mode On, Idle Mode On, Sleep Out	Yes																				
Sleep In	Yes																				
Default	<table border="1"> <thead> <tr> <th>Status</th> <th>Default Value</th> </tr> </thead> <tbody> <tr> <td>Power On Sequence</td> <td>00h,00h,00h</td> </tr> <tr> <td>S/W Reset</td> <td>00h,00h,00h</td> </tr> <tr> <td>H/W Reset</td> <td>00h,00h,00h</td> </tr> </tbody> </table>													Status	Default Value	Power On Sequence	00h,00h,00h	S/W Reset	00h,00h,00h	H/W Reset	00h,00h,00h
Status	Default Value																				
Power On Sequence	00h,00h,00h																				
S/W Reset	00h,00h,00h																				
H/W Reset	00h,00h,00h																				

12 REVISION HISTORY

Version	Date	Description
P 0.0	2020/05	First Issue
P 0.1	2020/06	Add timing, format, Cmd...
P 0.2	2020/07	Modify Cmd0xB6. & Page32 picture
P0.4	2020/12	Max resolution=400x480, Add RGB IF

Preliminary