

Interfacing OLED Display to MCU STC89LE52RC

The Serial(4-Wire SPI)Reference Example

Used internal Charge Pump

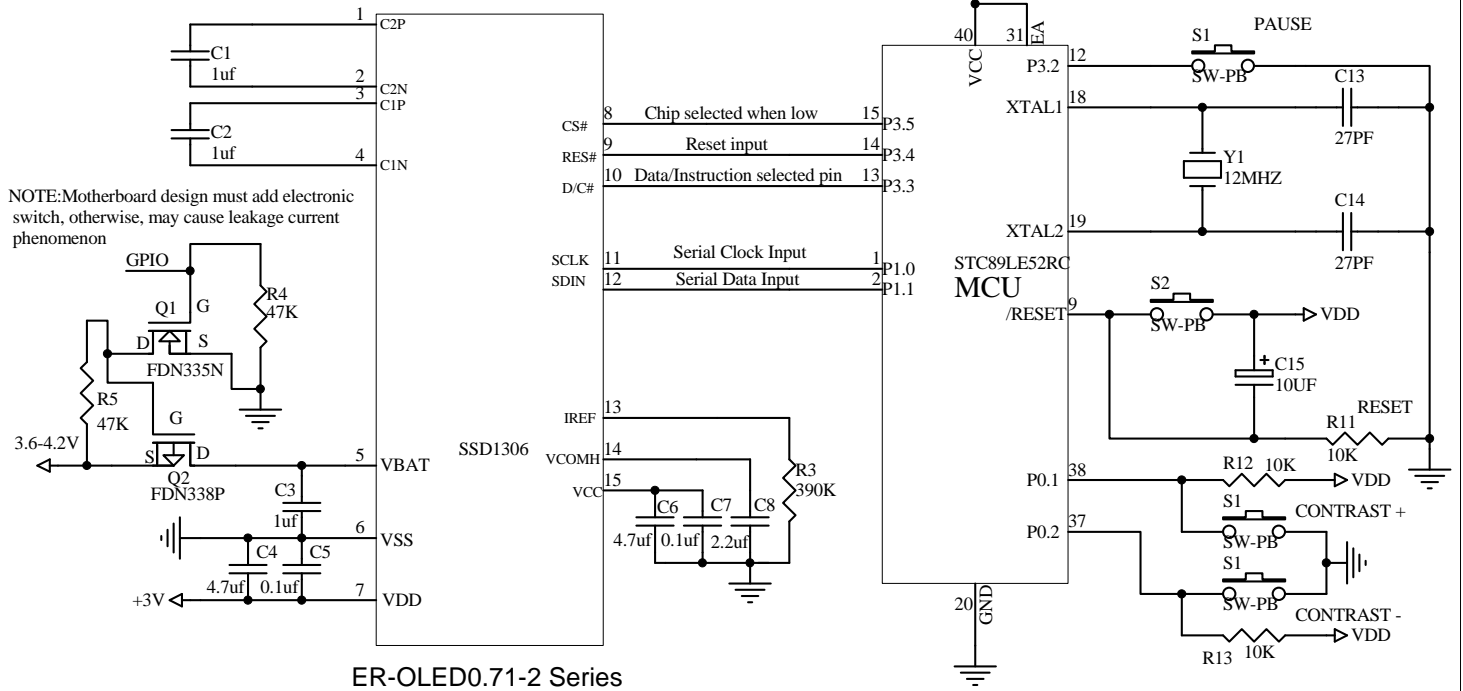

VCC Supplied Externally(Don't use internal Charge Pump)

NOTE: Motherboard design must add electronic switch, otherwise, may cause leakage current

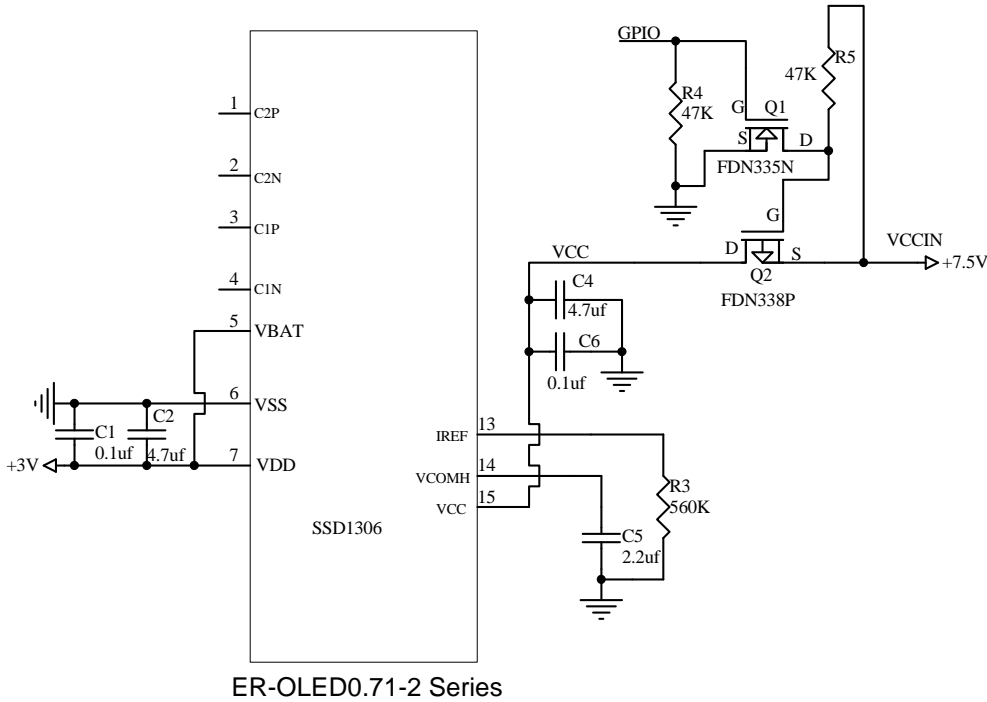

Title		
EASTRISING TECHNOLOGY CO.,LTD.		
Size	Number	Revision
A	ER-OLED0.71-2 Series	A0
Date:	Apr-25-2018	Sheet of
File		1
		Drawn By
		Javen