

# Interfacing OLED Display Module ER-OLEDM024-2 Series to MCU AT89C52

The Parallel (8080 Series MCU) Reference Example

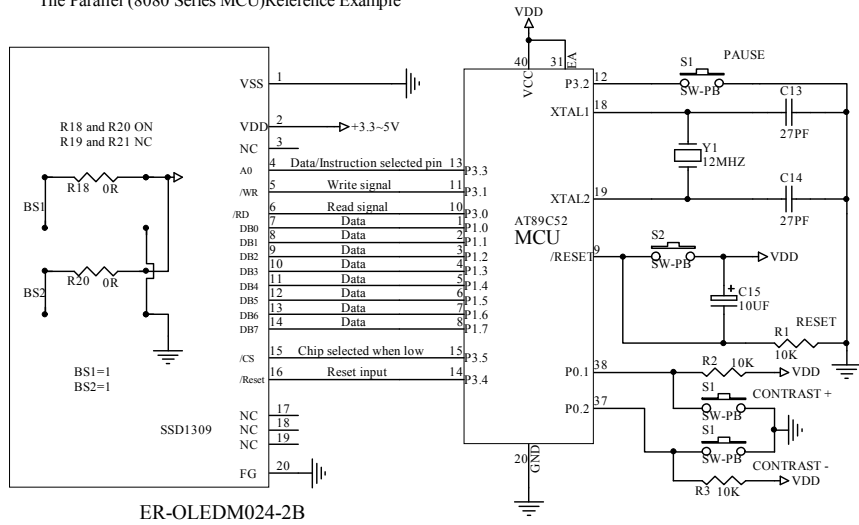

The Parallel (6800 Series MCU) Reference Example

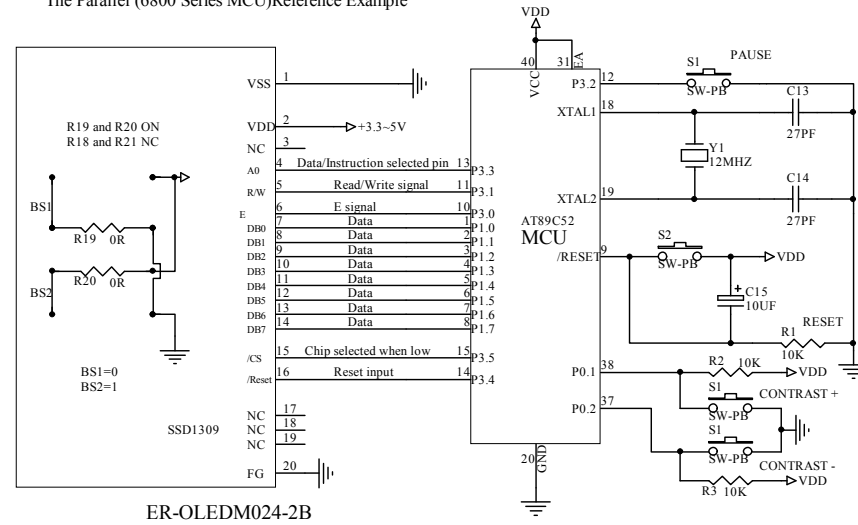

The Serial 4 Line SPI Reference Example

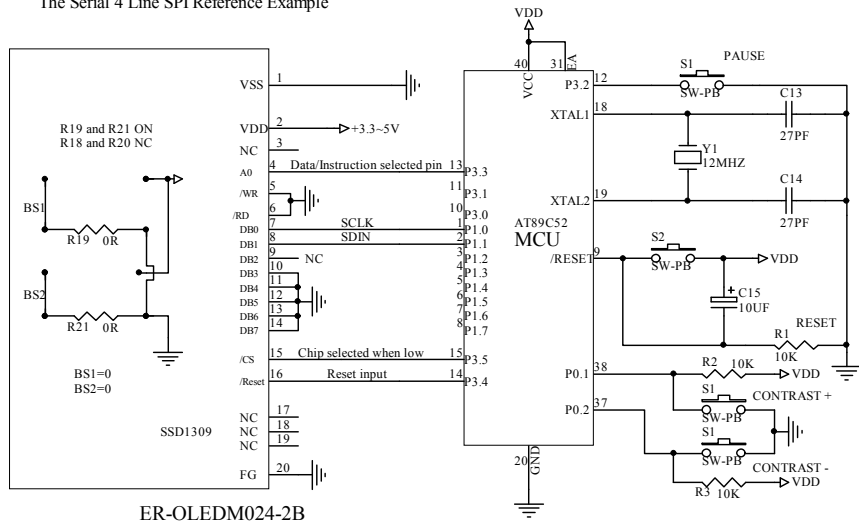

The Serial I2C Reference Example

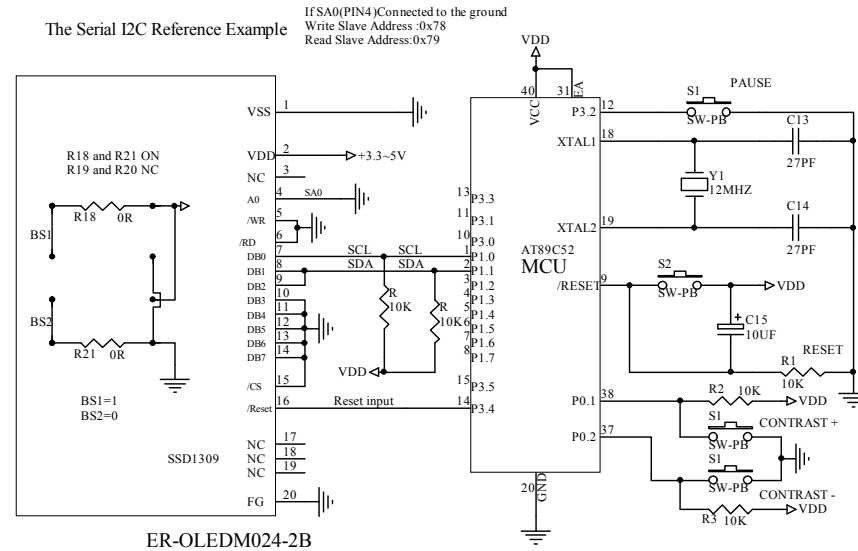

Title <b>EASTRISING TECHNOLOGY CO.,LTD.</b>		
Size <b>A</b>	Number <b>ER-TFTM024-2 Series</b>	Revision <b>A0</b>
Date: 11-Nov-2014	Sheet of 1	
File	Drawn By Javen	