

Interfacing OLED Display to the AT89LV52 MCU

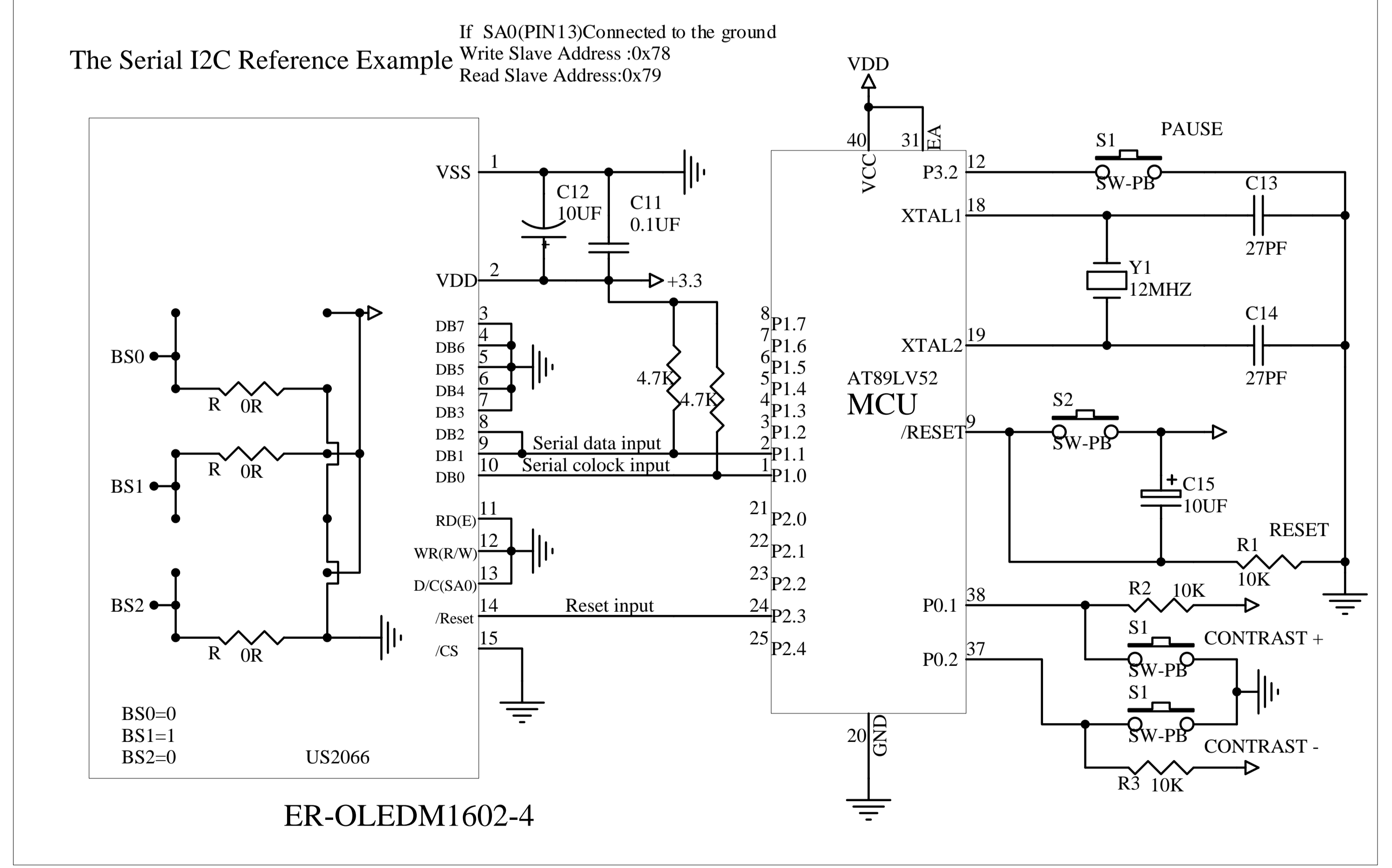
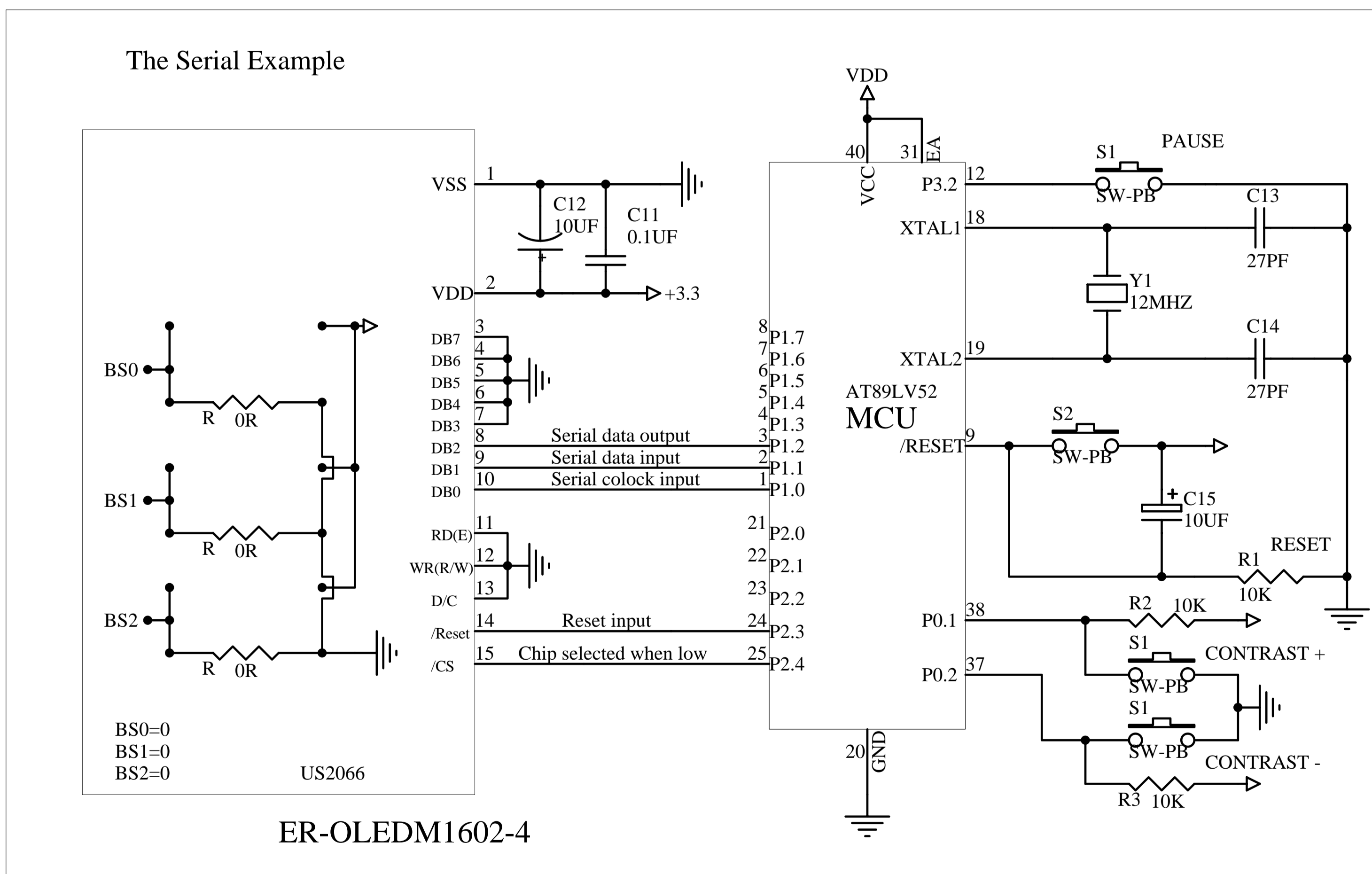
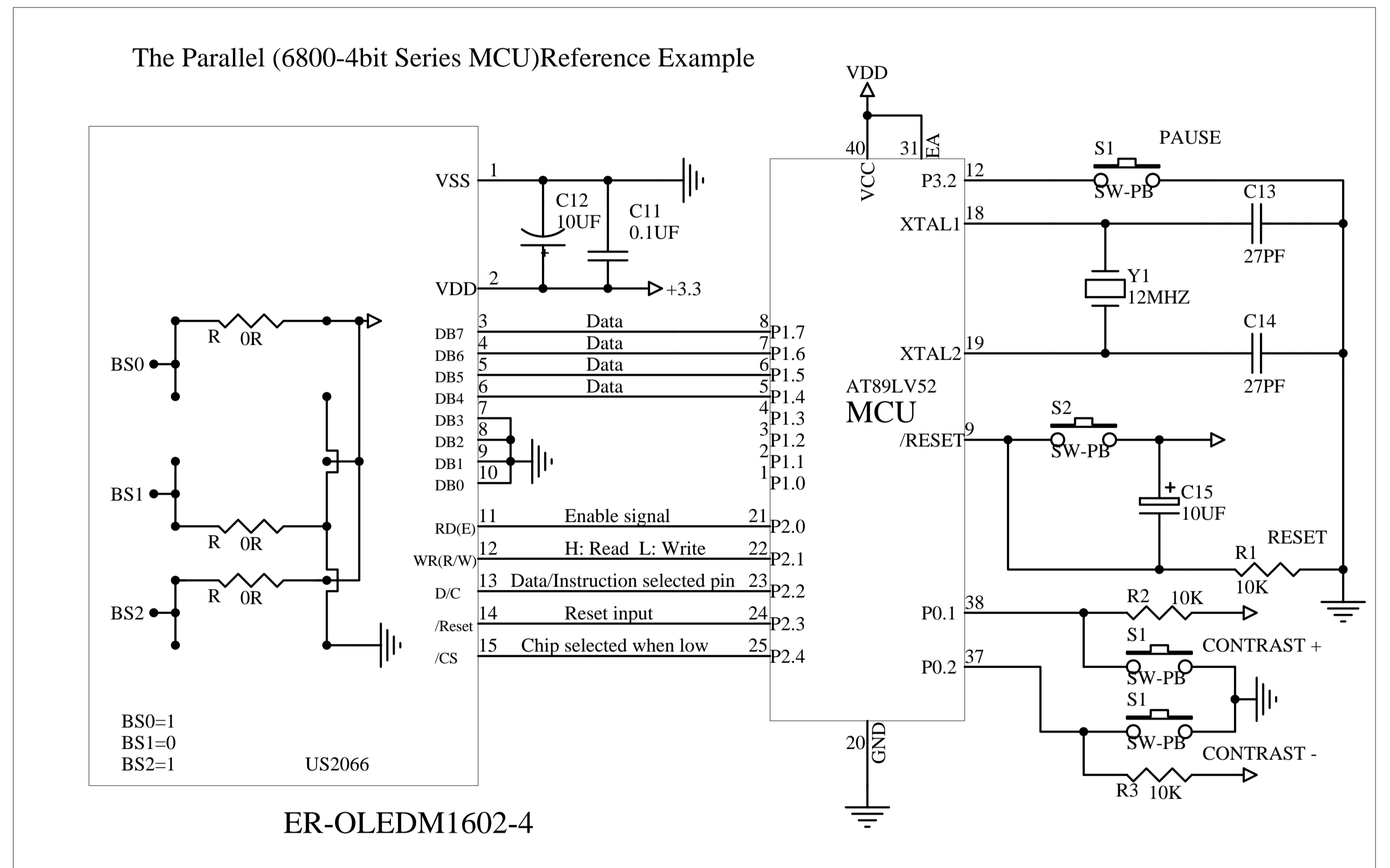
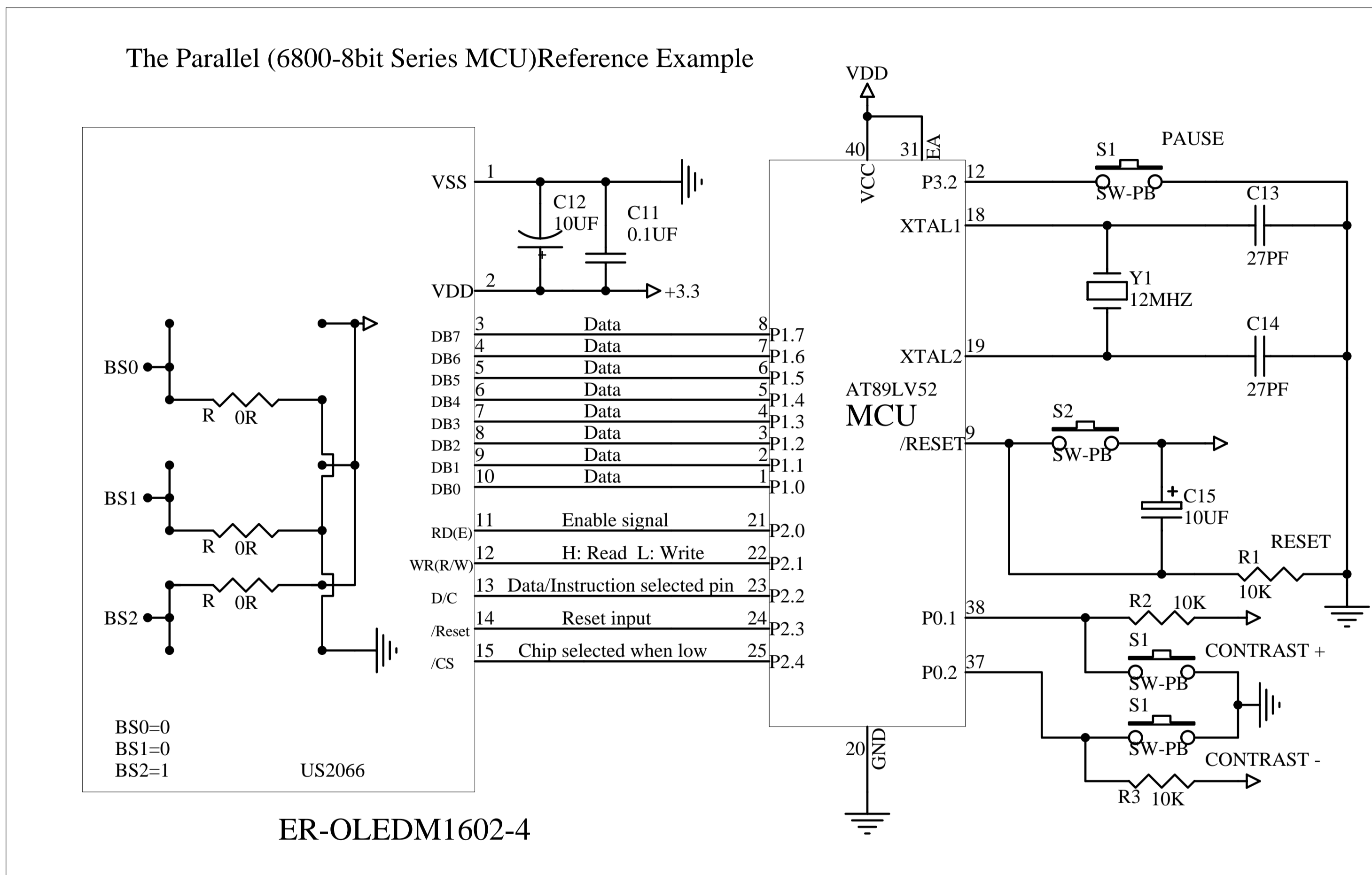
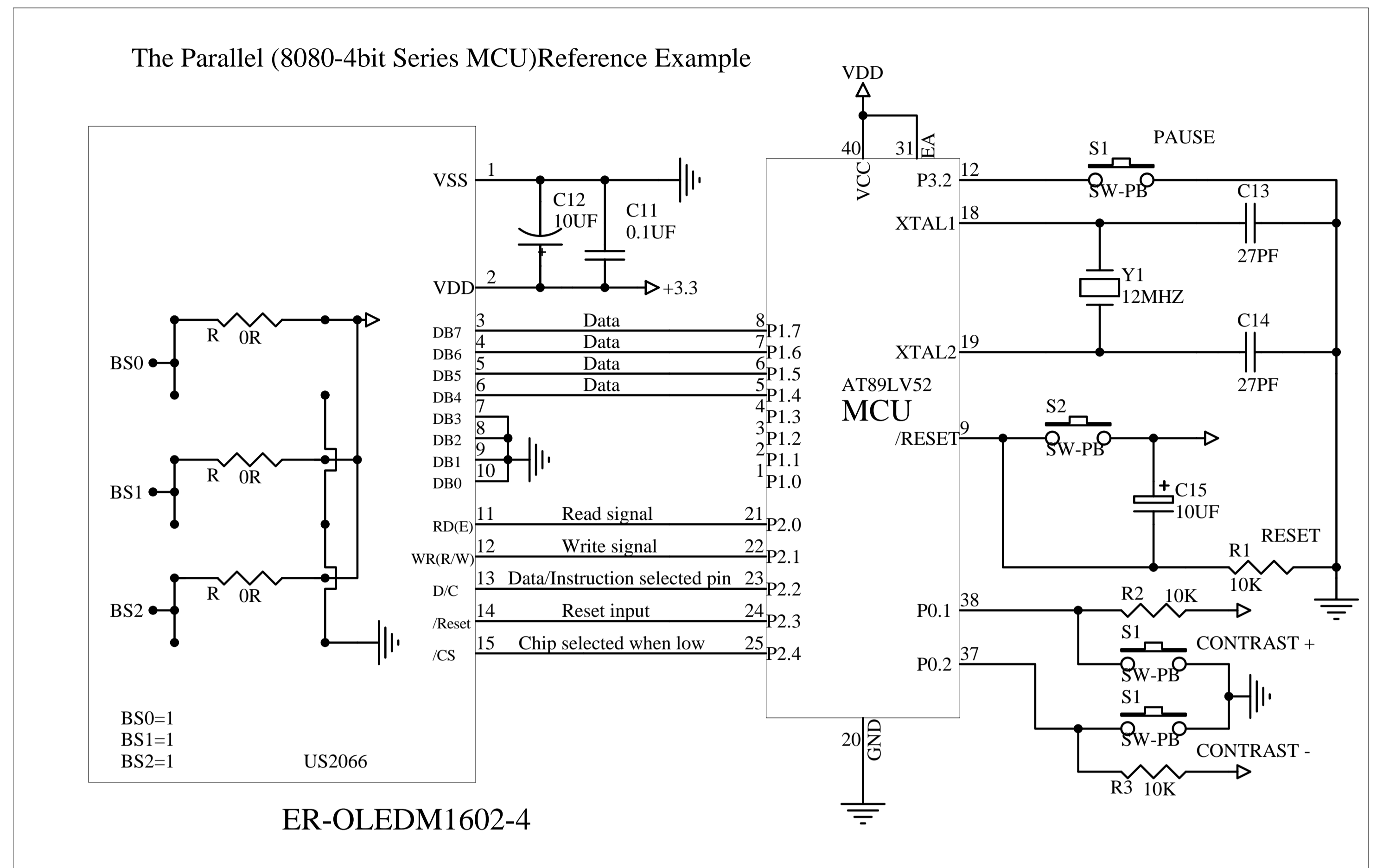
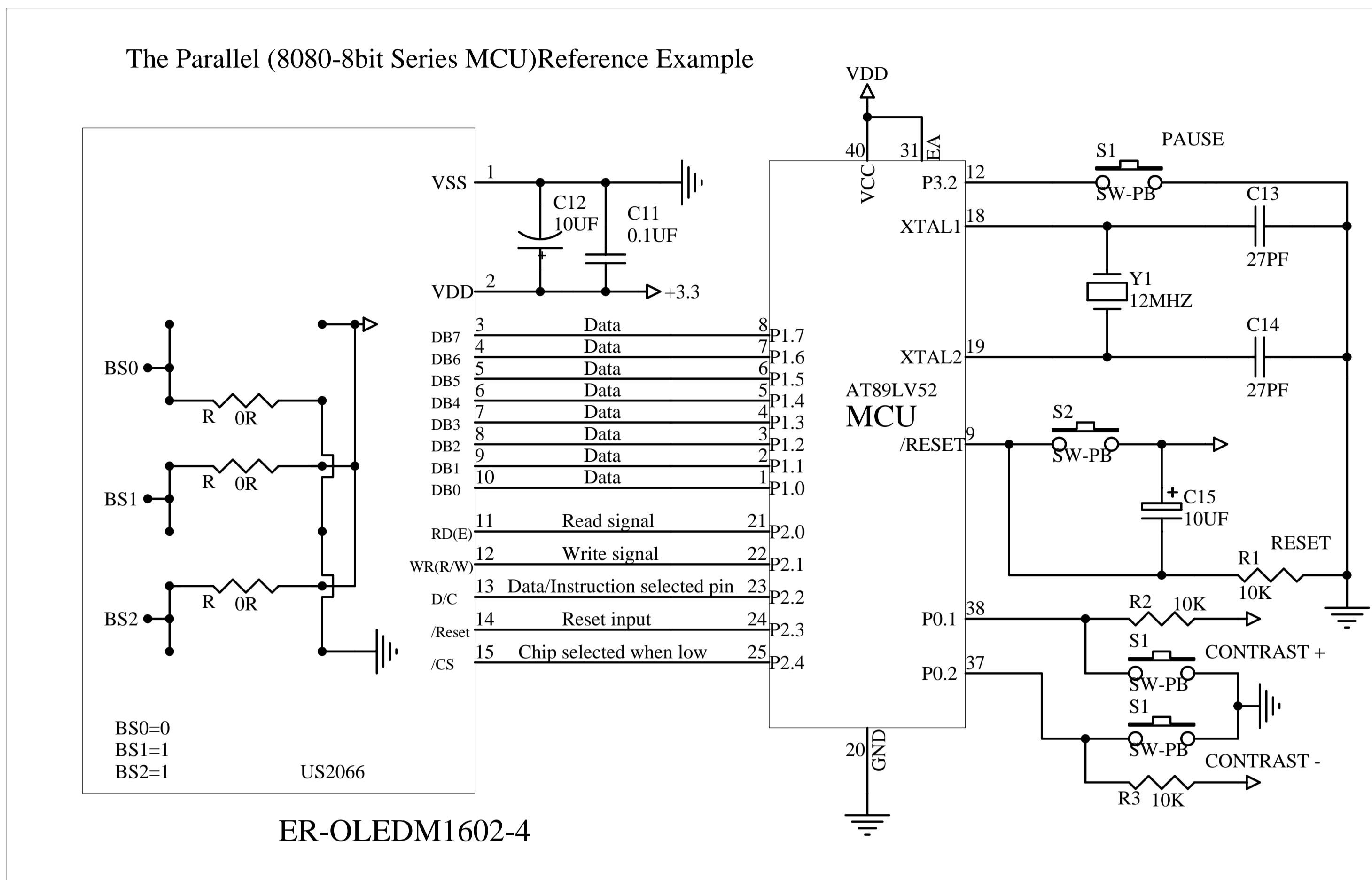

Title EASTRISING TECHNOLOGY CO.,LTD.			
Size A	Number ER-OLEDM1602-4	Revision A0	
Date: 03-Feb-2010	Sheet of 1		Drawn By Javen
File			