

TFT LCD MODULE ER-TFT022-1 to MCU STC12LE5A60S2 Interfacing

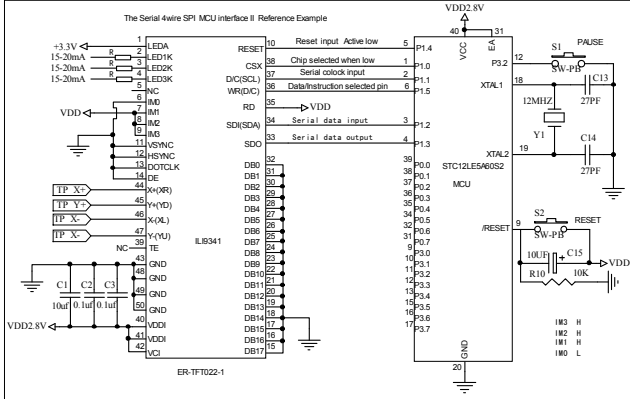

RGB Interfacing

LCD Modules to the LCD Controller or Built-in LCD controller MCU

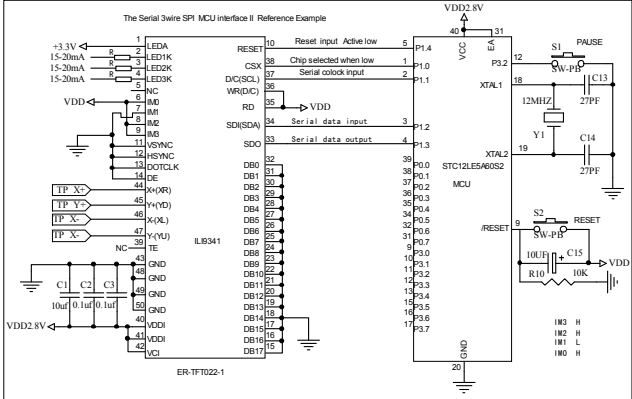
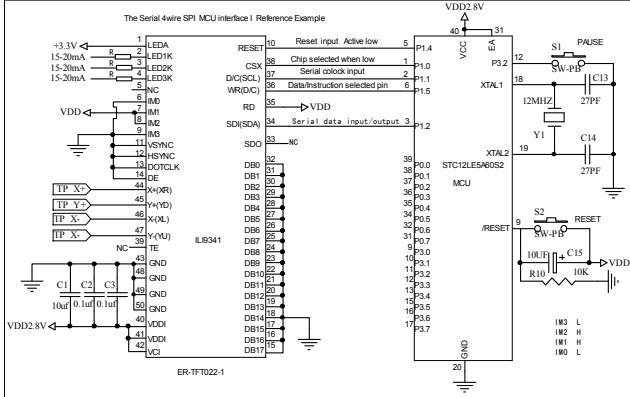
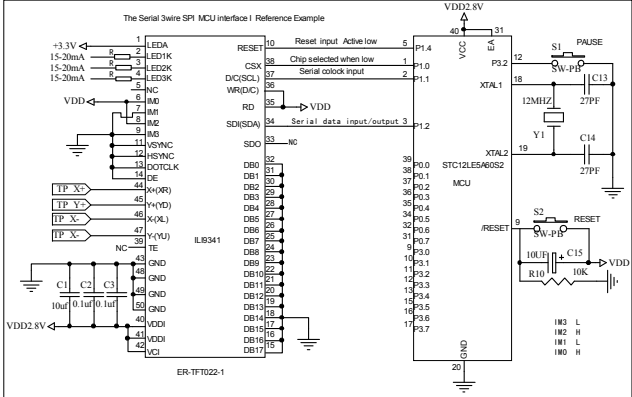
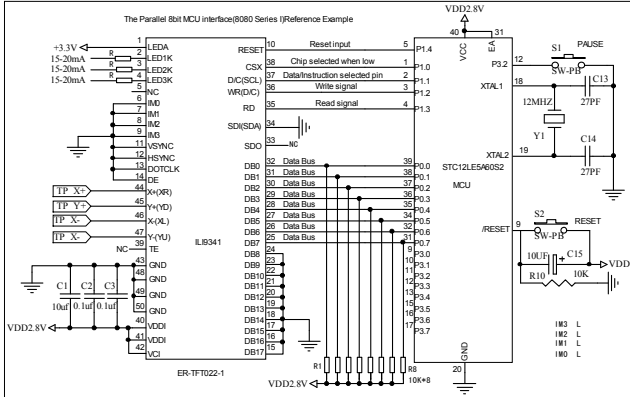
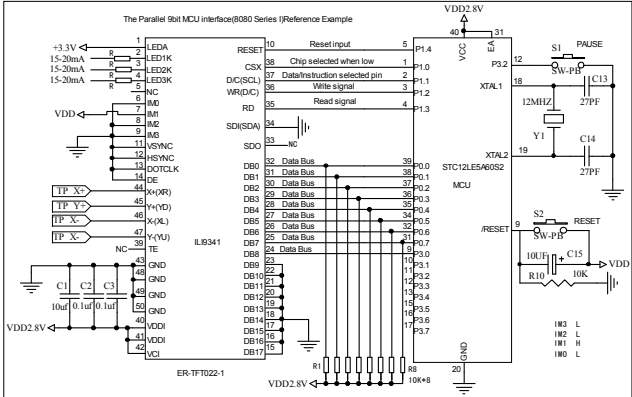
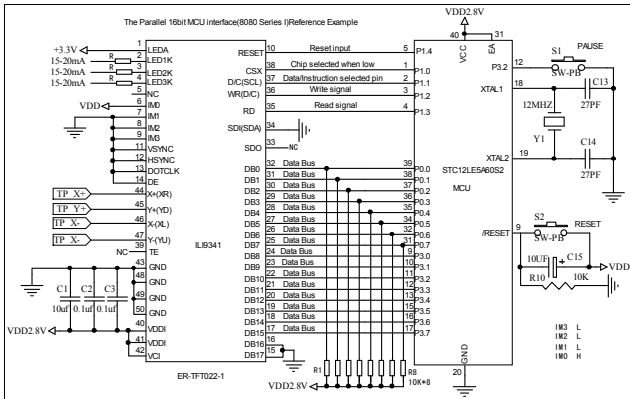
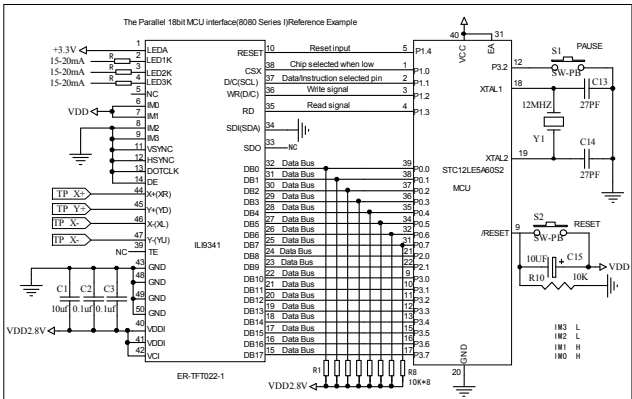
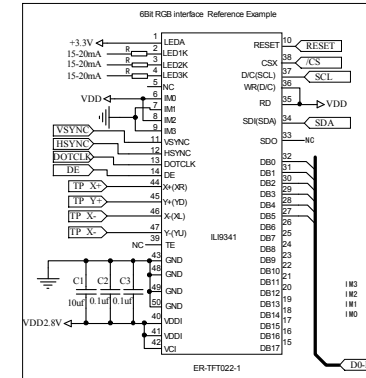
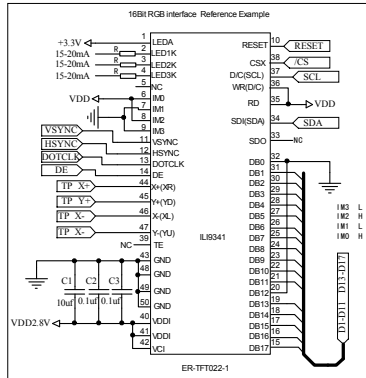
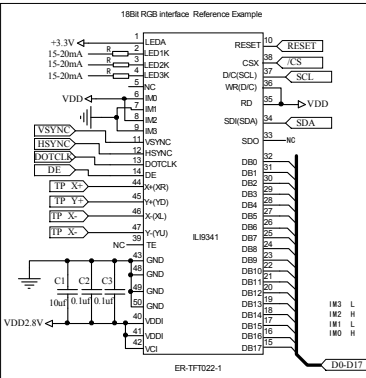

Title EASTRISING TECHNOLOGY CO., LTD.

REV.	DESCRIPTION OF MODIFY	MODIFY BY	DATE	Size	Number	Revision
A0	1 ST DESIGN	JW	Apr/07/2015	A	ER-TFT022-1	A0
A1						
A2						

Date: Apr/07/2015
Sheet of 1
Drawn By: Javen