

Interfacing ER-TFT028-4 with Capacitive Touch Panel to MCU STC12LE5A60S2

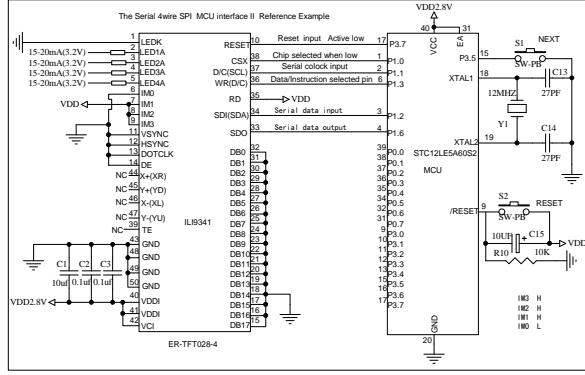

RGB Interfacing LCD Modules to the LCD Controller or Built-in LCD controller MCU

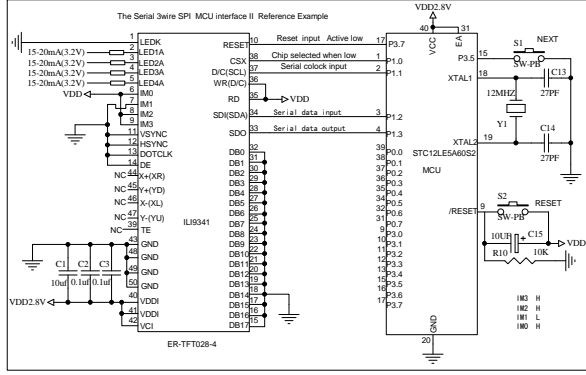
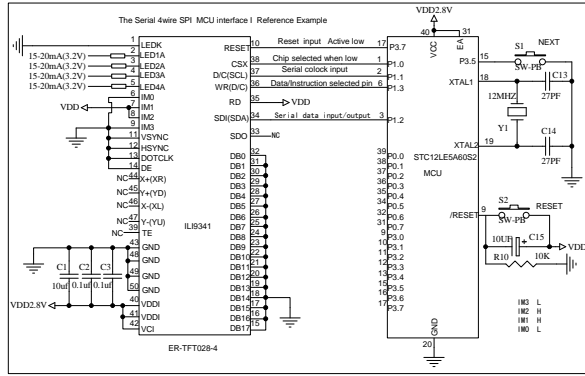
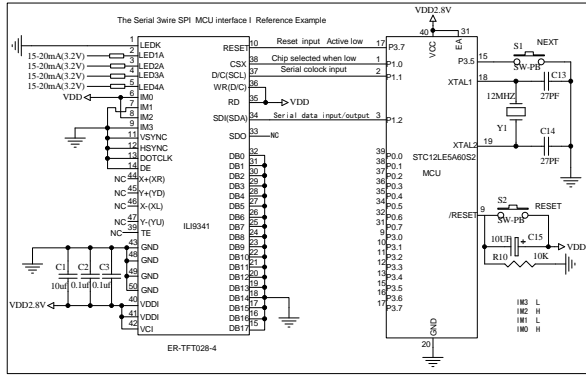
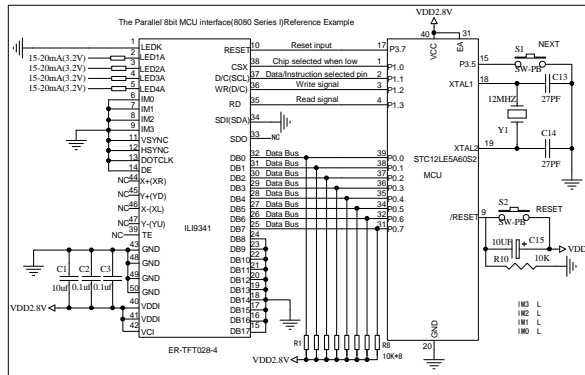
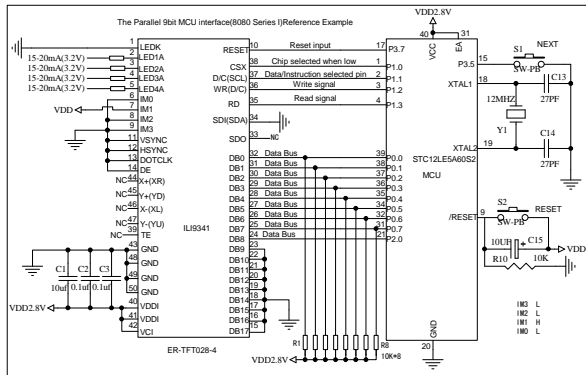
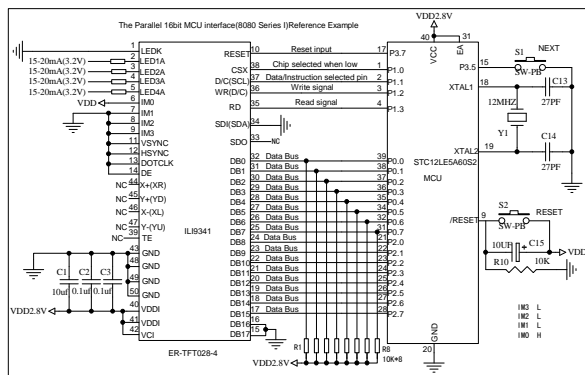
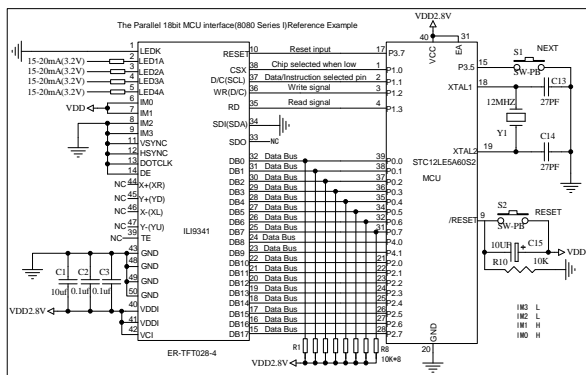
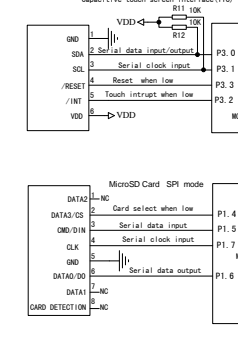
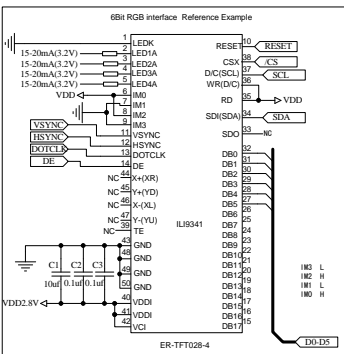
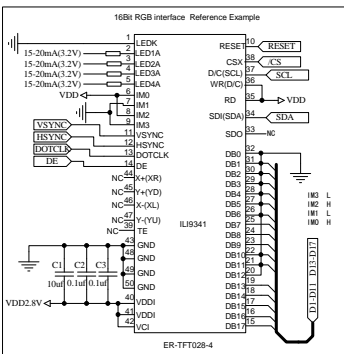
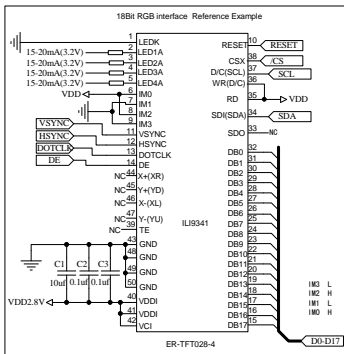

REV.	DESCRIPTION OF MODIFY	MODIFY BY	DATE	Size	Number	Revision
A1	1 ST DESIGN	JIM	23-JAN-2013	A	1	A0
A2	2 ND DESIGN	JIM	26-FEB-2015	A	1	A0