

Interfacing TFT LCD Module ER-TFTM022-1 to MCU STC12LE5A60S2

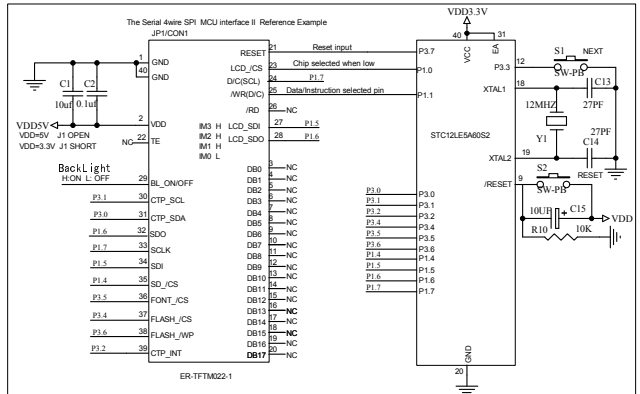

RGB Interfacing LCD Modules to the LCD Controller or Built-in LCD controller MCU

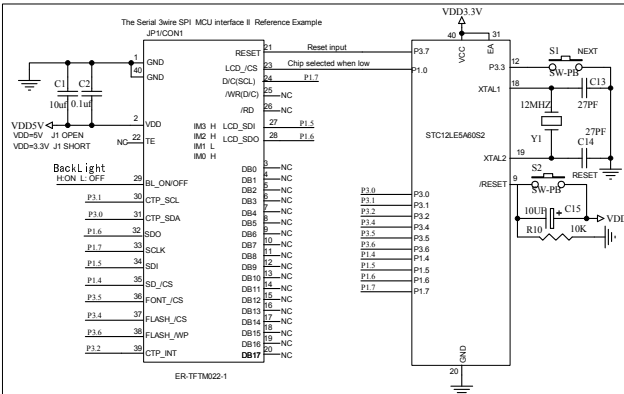
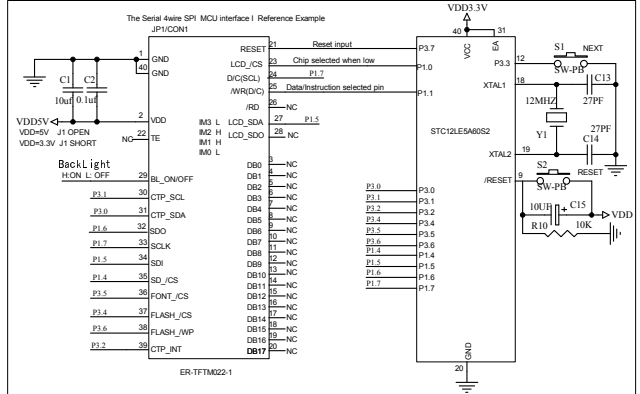
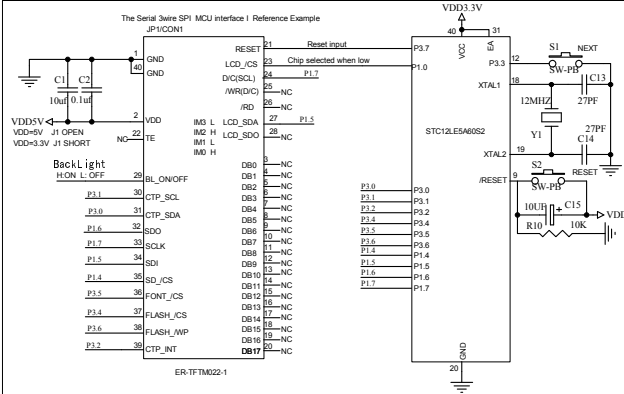
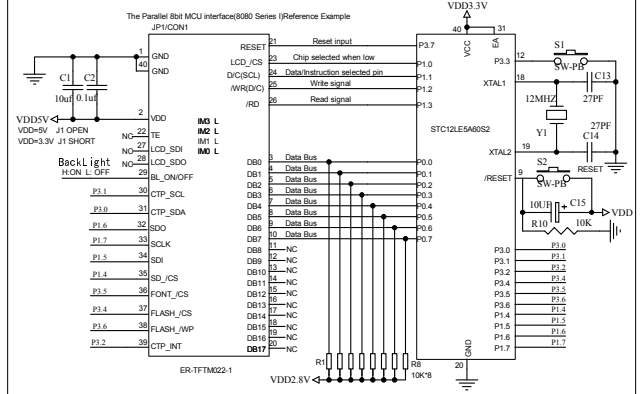
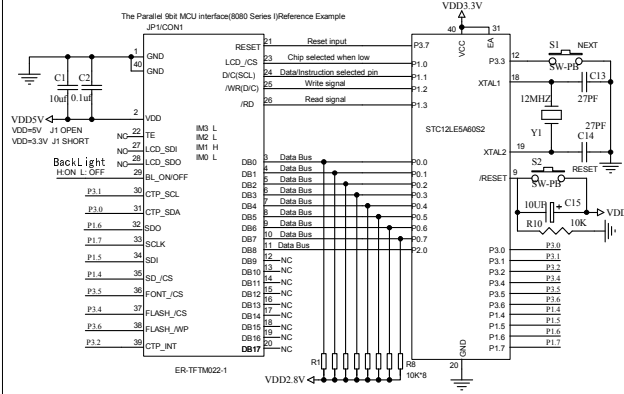
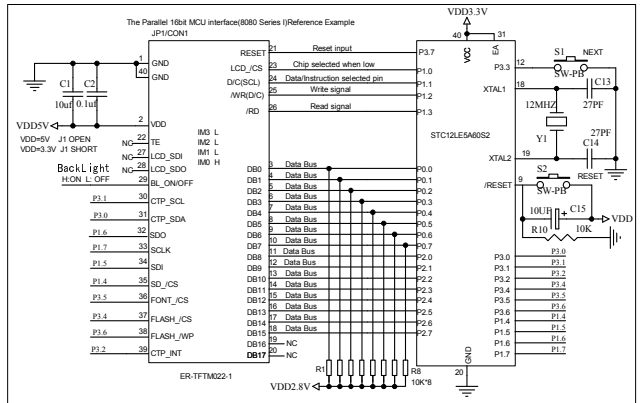
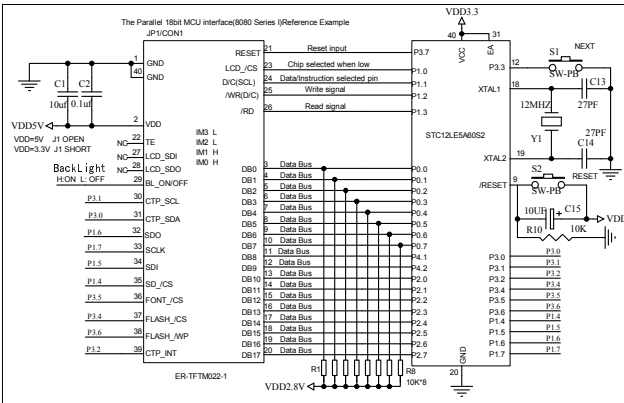
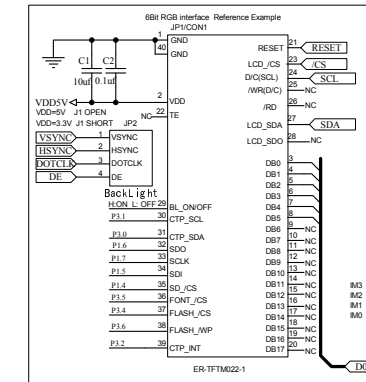
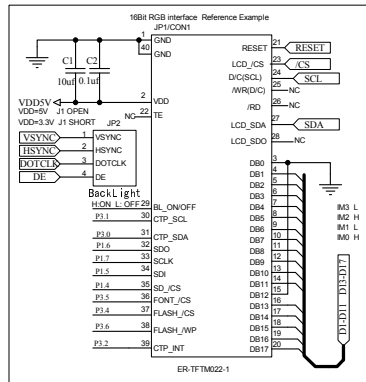
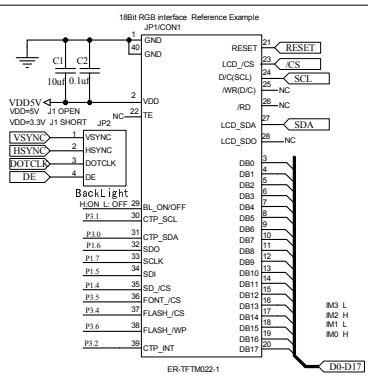

REV.	DESCRIPTION OF MODIFY	MODIFY BY	DATE	Size	Number	Revision
A0	1 ST DESIGN	JJM	17-NOV-2020	A	ER-TFTM022-1-CTP	A0
A1				Date:	17-NOV-2020	Sheet of 1
A2				File		Drawn By Javen