

Interfacing 7" TFT LCD Module(ER-TFTM070-5) to MCU 8051(STC12LE5A60S2)

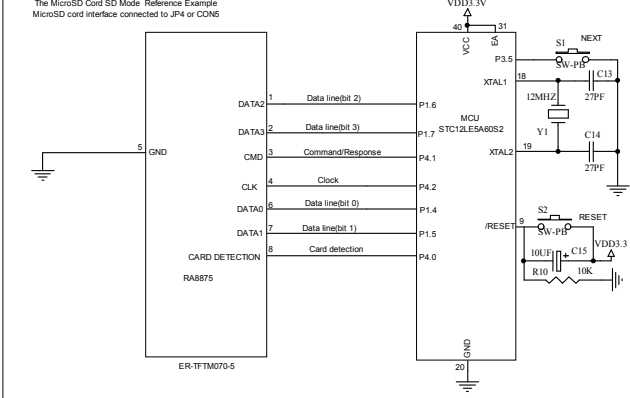
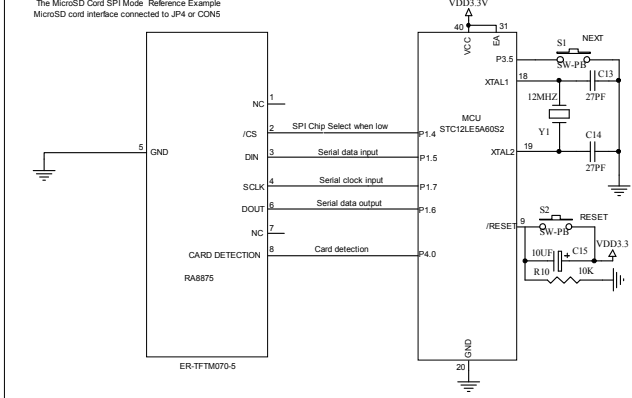
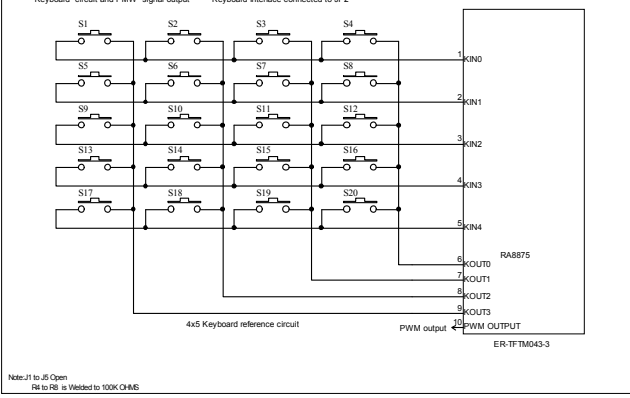
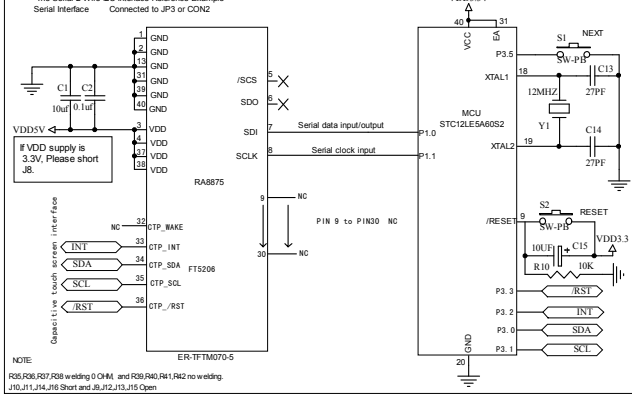
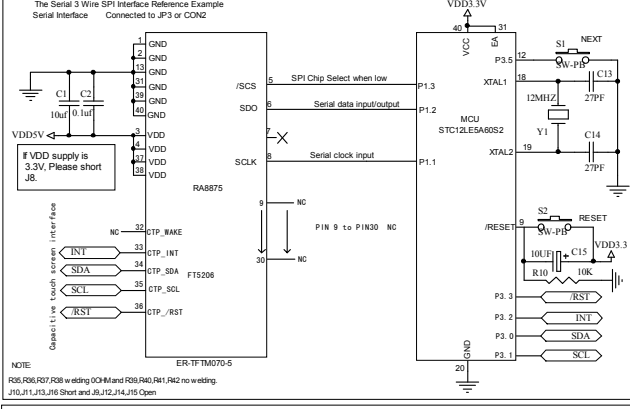
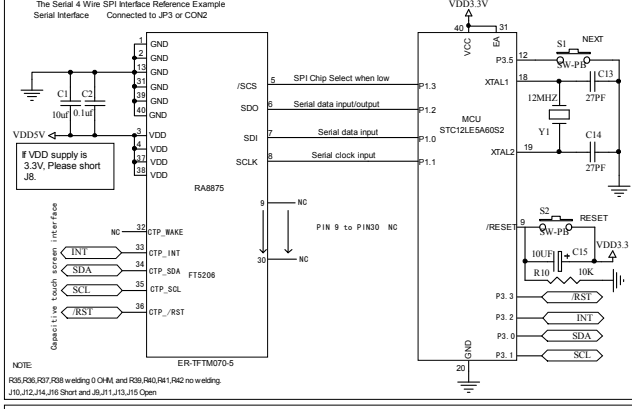
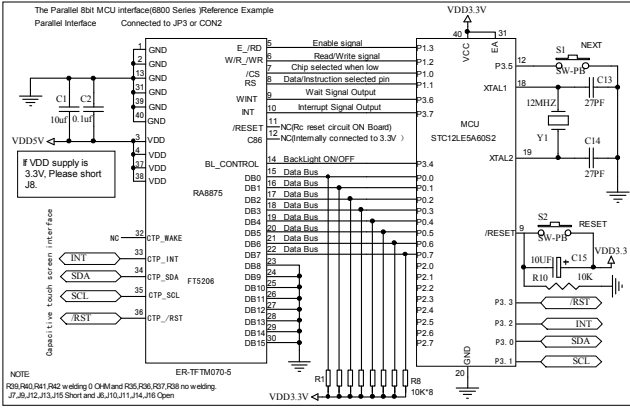
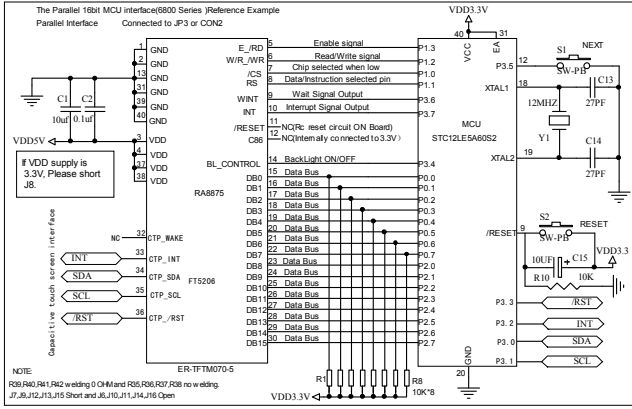
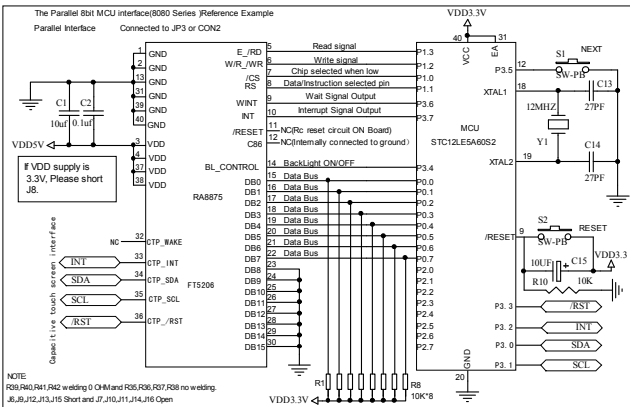
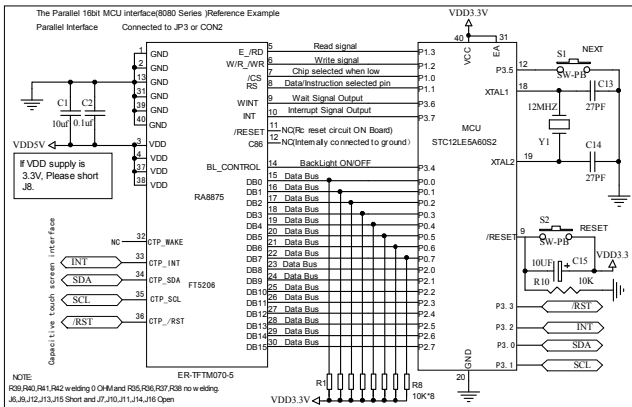

REV.				Title		Size		Number		Revision	
A0	1 ST DESIGN	J1W	Nov-29-2013	EASTRSING TECHNOLOGY CO.,LTD.		A		ER-TFTM070-5		AD	
A1	Modified PINs, 10, 14 description	J1W	Dec-06-2014							1	
				Date:	Nov-29-2013					Sheet of 1	
				File:						Drawn By: J1W	