

# Interfacing LCD Modules to the AT89LV52 MCU

The Parallel 8Bit(8080 Series MCU)Reference Example

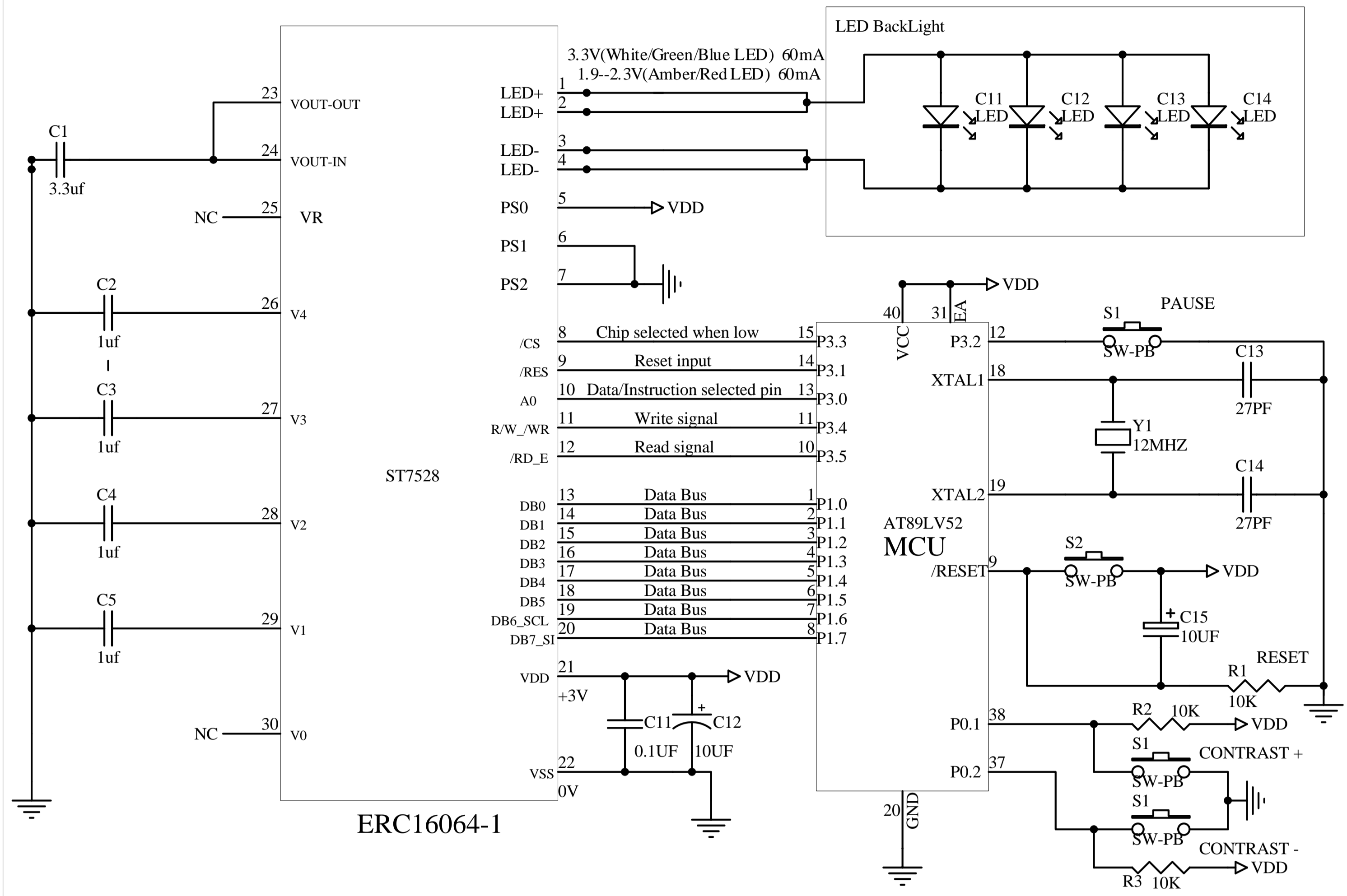

The Parallel 8Bit(6800 Series MCU)Reference Example

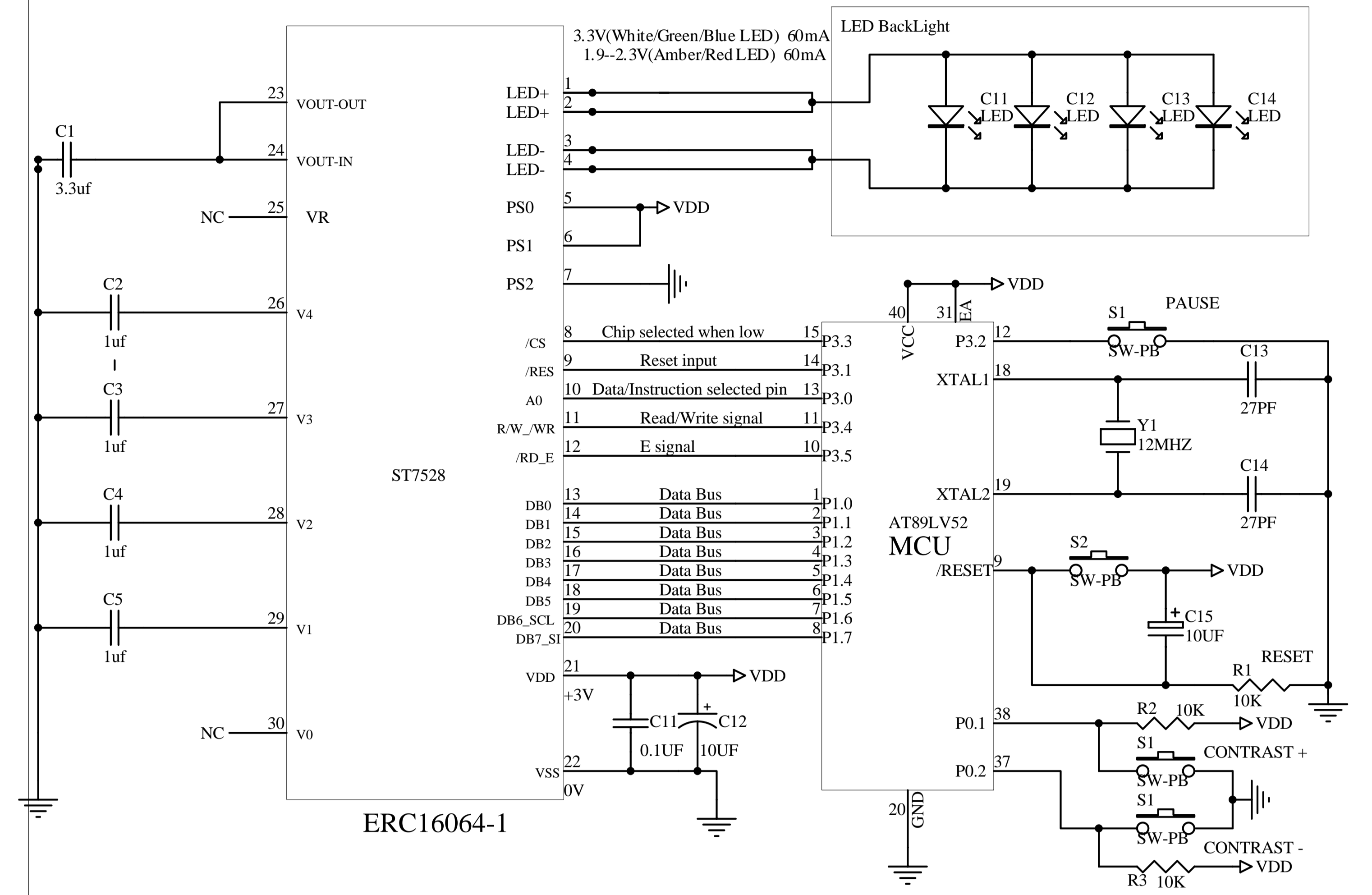

The Serial 3line SPI Reference Example

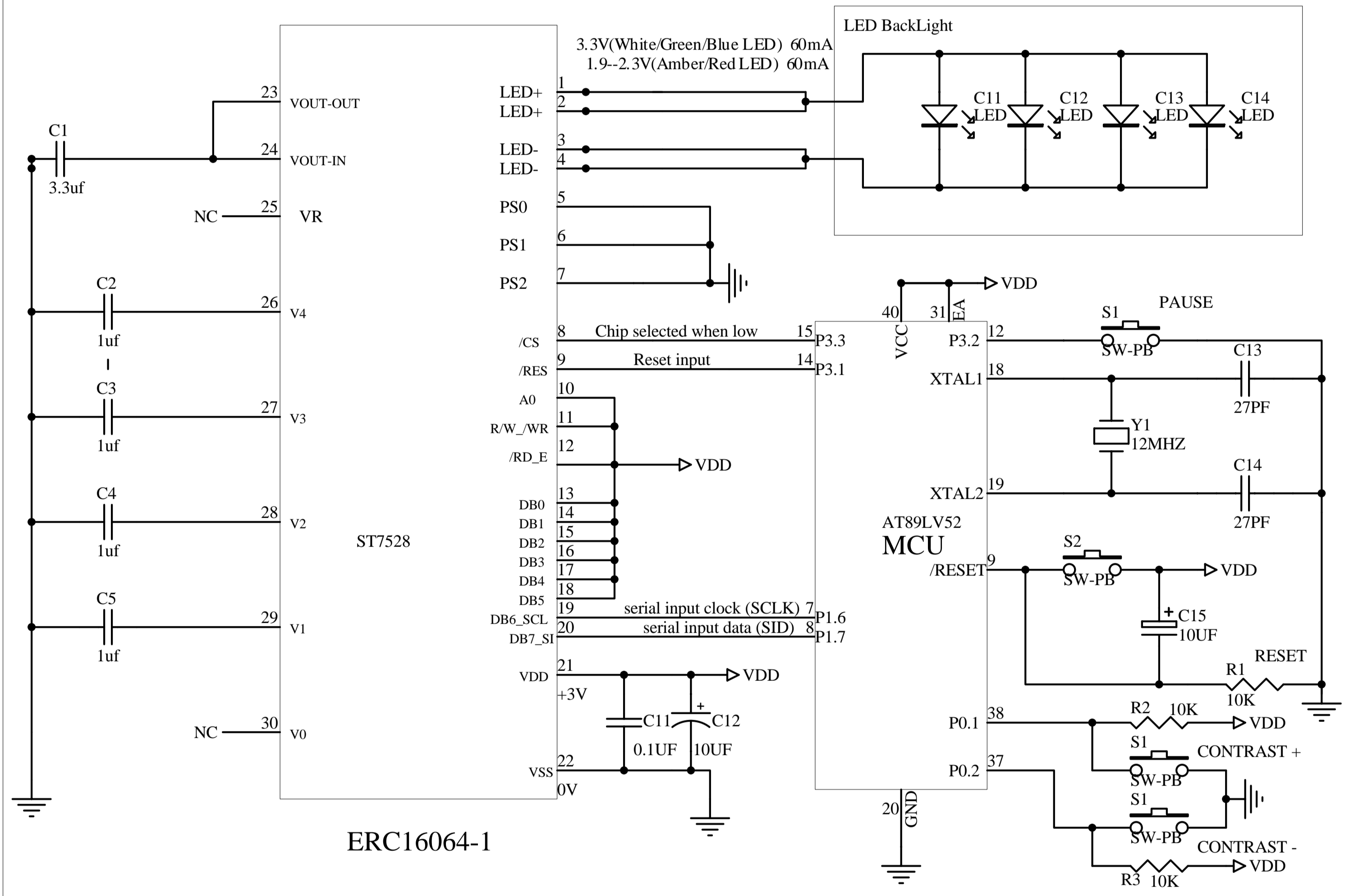

The Serial 4line SPI Reference Example

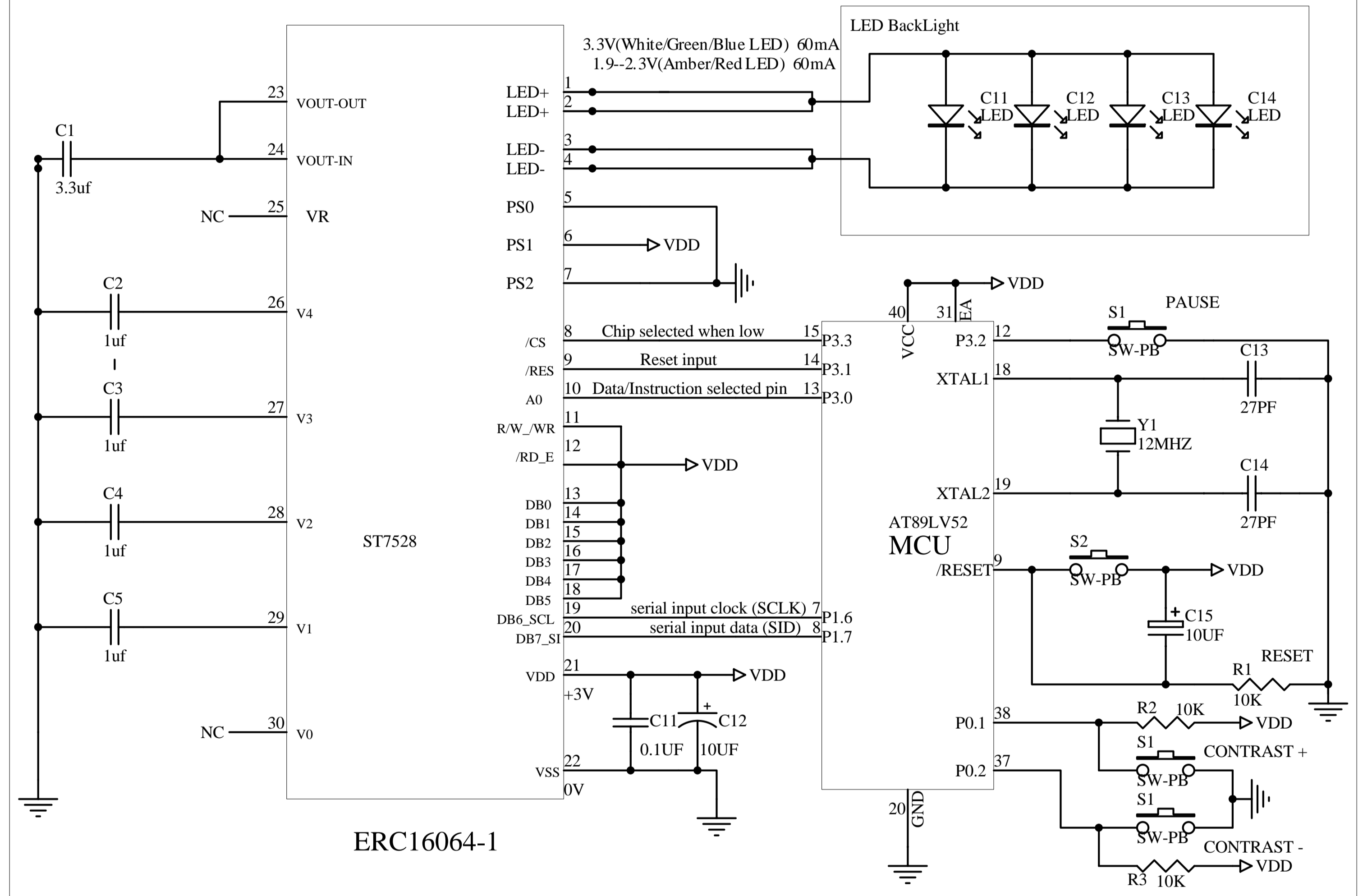

The Serial I2C Reference Example

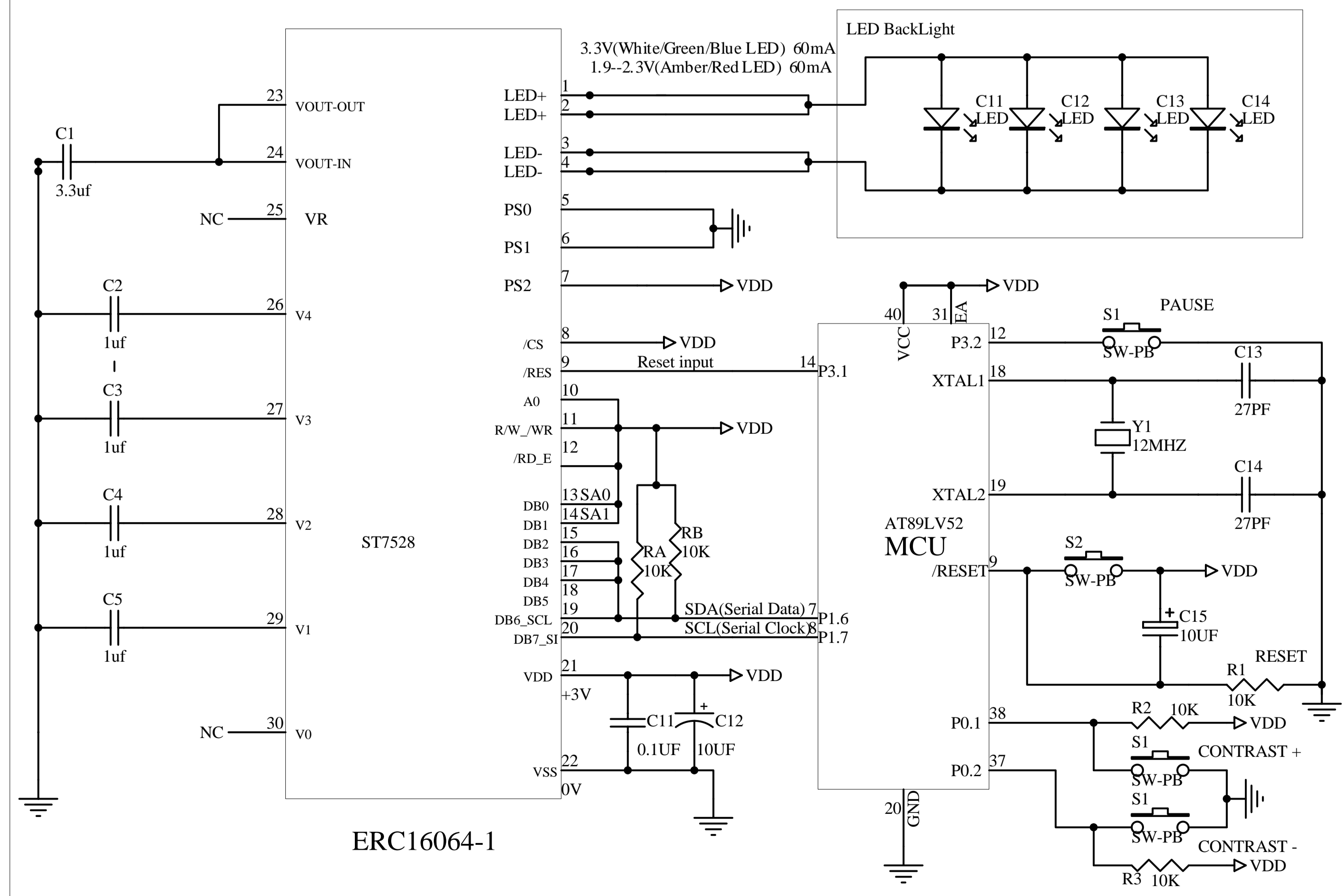

Title	EASTRISING TECHNOLOGY CO.,LTD.		
Size	Number	ERC16064-1	Revision
	A		A0
Date:	21-Jun-2009	Sheet of	1
File		Drawn By	Javen