

Interfacing LCD Modules to the AT89LV52 MCU

The Parallel (8080 8bit Series MCU)Reference Example

The Parallel (6800 8bit Series MCU)Reference Example

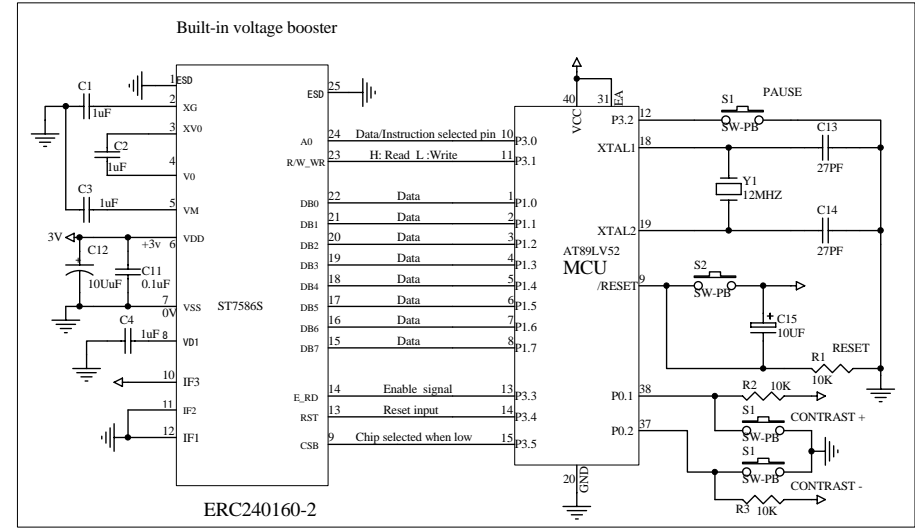
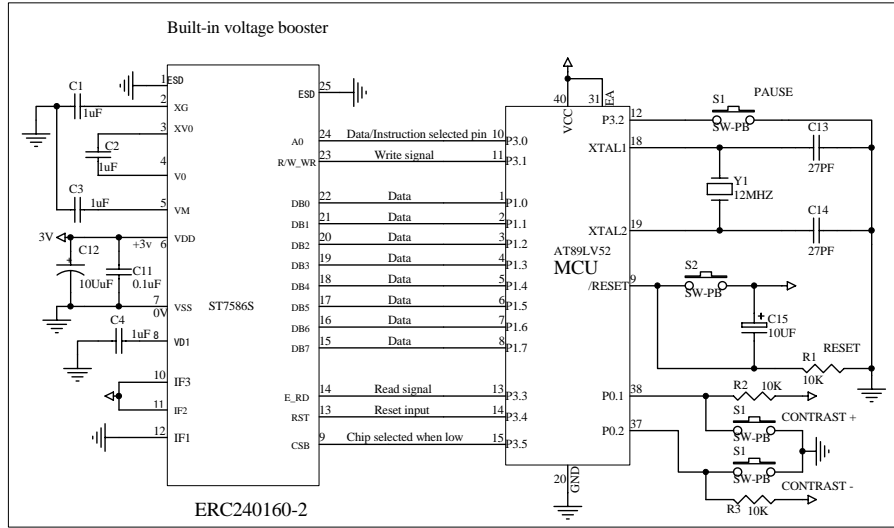

The Serial (4 LINE SPI S8)Reference Example

The Serial (3 LINE SPI S9)Reference Example

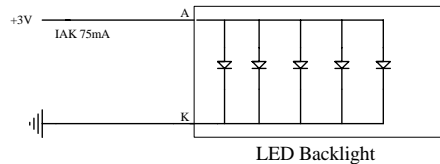
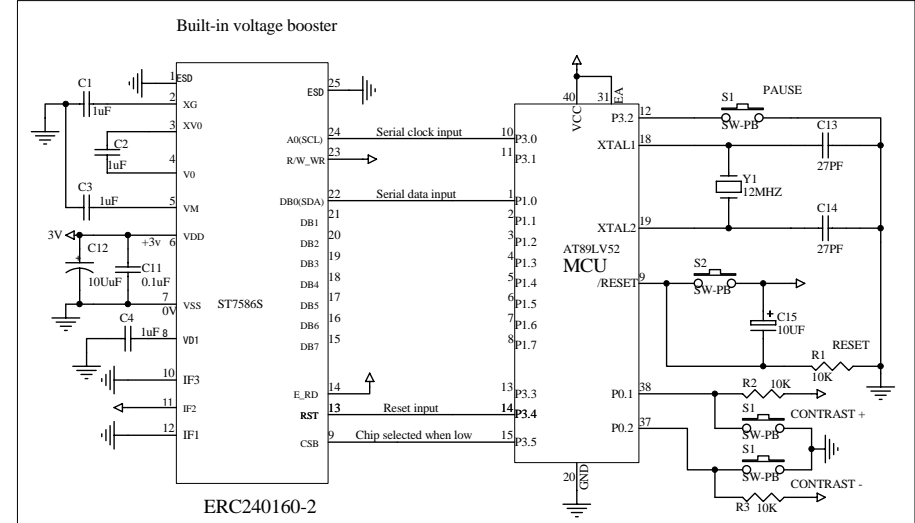
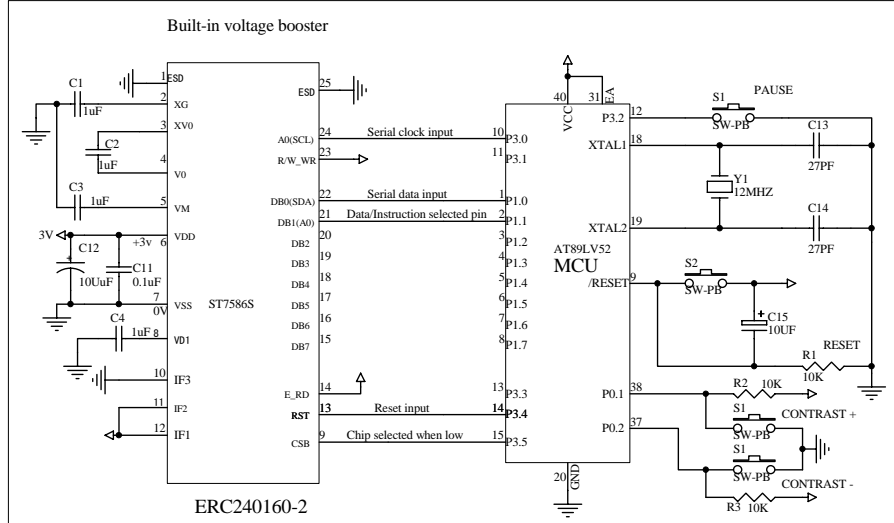

RST pin is optional. When RST pin is not used ,connect the pin to VDD

REV	MODIFY BY	DATE	DESCRIPTION OF MODIFY
A0	JJM	2011.4.18	1 ST DESIGN
A1	JJM	2012.12.12	MODIFY CSB NUMBER AND VDI EXTERNAL CIRCUIT

Title **EASTRISING TECHNOLOGY CO.,LTD.**

Size	Number	Revision
A	ERC240160-2	A0

Date:	Jul-03-2017	Sheet of	1
File:		Drawn By	Javen