

Interfacing ERMC240128-2 Series to the MCU STC89LE52

The 5V power supply, Parallel 8Bit(8080 Series MCU)Reference Example

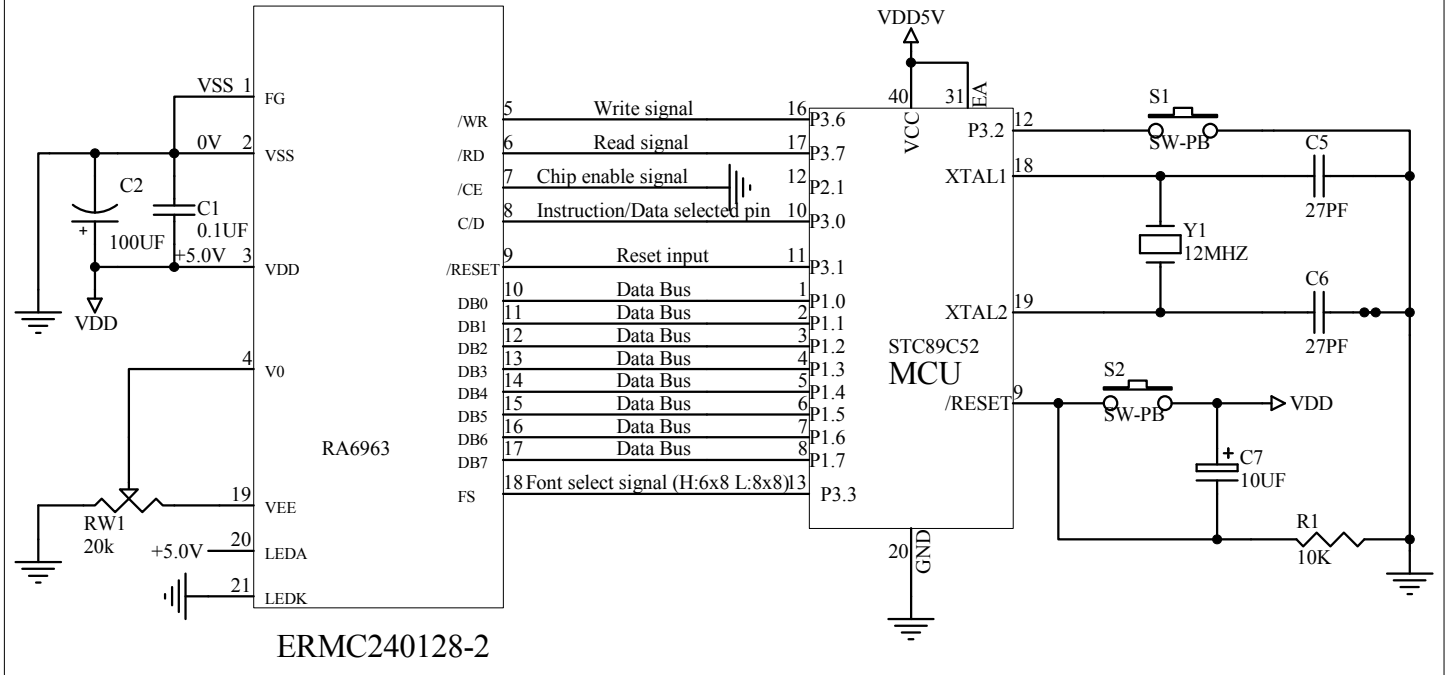

The 3.3V power supply, Parallel 8Bit(8080 Series MCU)Reference Example

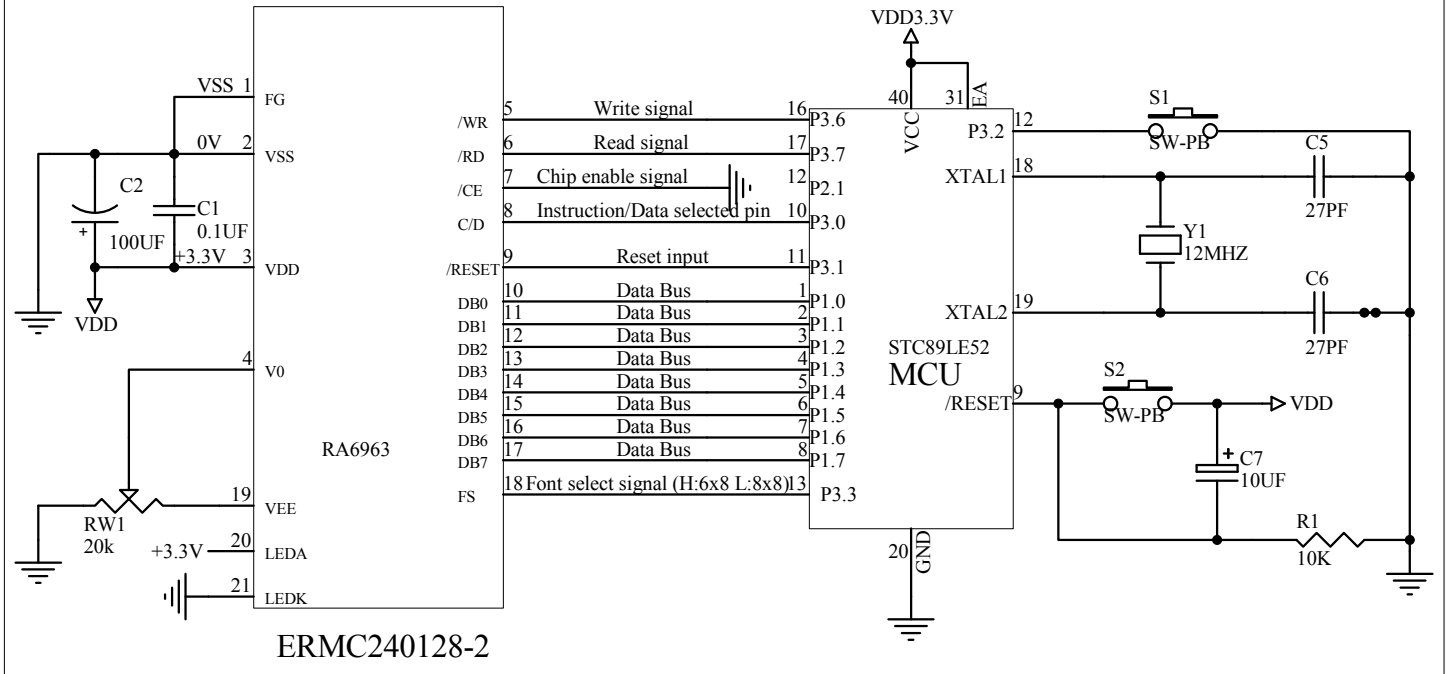

Title				EASTRISING TECHNOLOGY CO.,LTD.			
Size		Number		Revision			
A		ERMC240128-2		A0			
Date:				30-Dec-2020		Sheet of 1	
File						Drawn By Javen	