

Customer Approved by:

REV	DESCRIPTION	DESIGN	DATE
A	1'ST DEGIN	JIM	Jun-06-2013

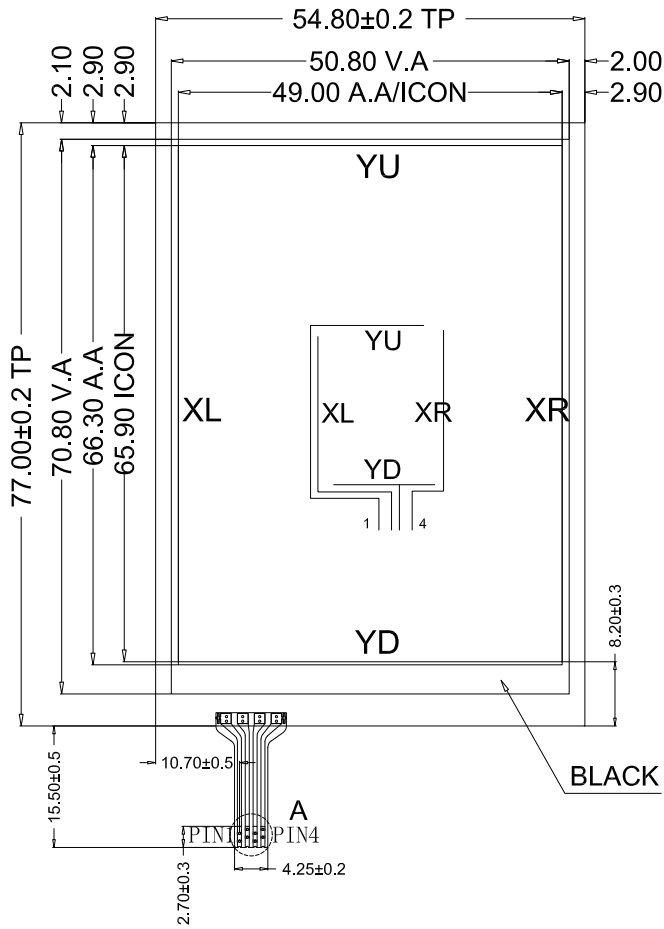

Top View

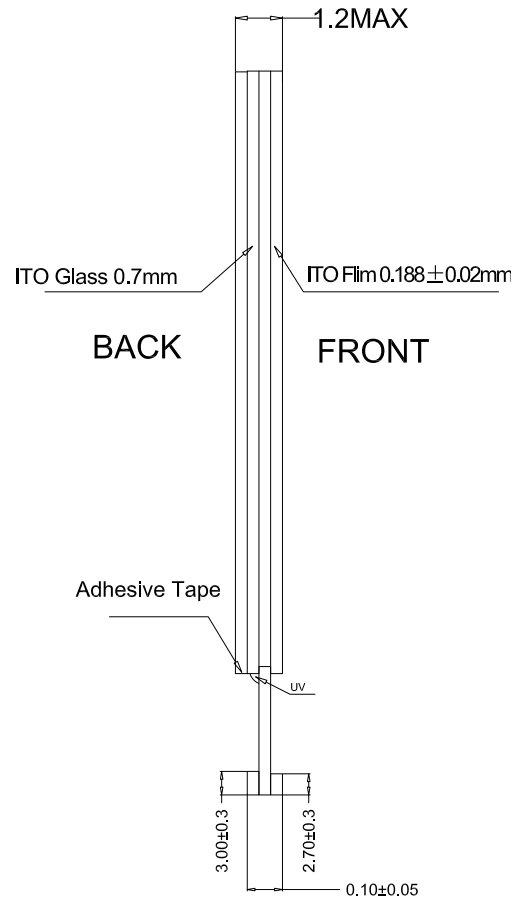

Side View

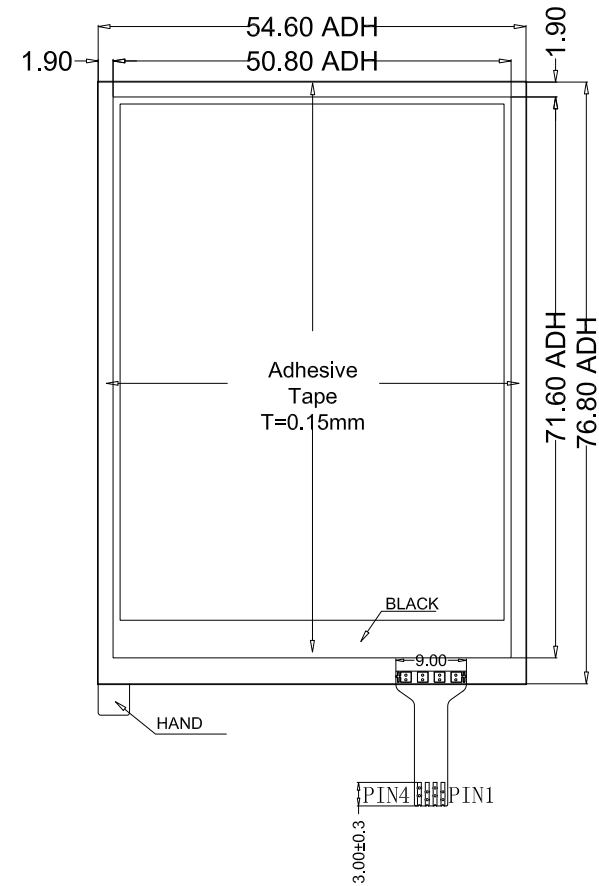

Bottom View

Notes:

- Type: Film to Glass
- Operating Voltage: ≤10V
- Operation Temperature: -10°C ~ 60°C  
Storage Temperature: -20°C ~ 70°C
- Life Time: ≥1,000,000 times
- Connect Material: FPC
- Response Time: ≤10ms
- Linearity: ≤1.5%
- Transmittance: ≥80%
- Surface Hardness ≥3H (Pencil)
- operation Force: 20g ~ 80g
- Resistance:  
(Clear Hard ITO Film )X: 150Ω ~ 500Ω  
(Stand Hard ITO Glass)Y: 350Ω ~ 850Ω
- Unspecified Tolerance: ±0.20

NO.	SYMBOL
1	YU
2	XL
3	YD
4	XR

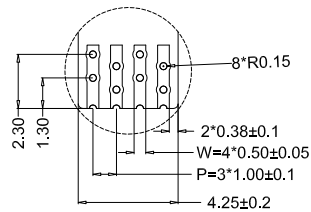

Detail A  
SCALE 3:1

 <b>EastRising</b> buydisplay.com		深圳旭日东方科技有限公司 <b>EASTRISING TECHNOLOGY CO.,LTD</b>			
		TEL: 86-755-33503874 33503873 33503871      FAX: 86-755-33507642-801			
APPROVALS	DATE	Part Number : <b>ER-TP032-2</b>		GENERAL TOL.	UNITS
APP				SCALE:	MM
CHK		DO NOT SCALE THIS DRAWING.	PROJECTION	N.T.S.	
DWN	JIM			160606	SHEET: