

NOTES:

- 1.The general tolerance is $\pm 0.20\text{mm}$.
- 2.All materials in the drawing comply with the RoHS.

| | | |
|-----|-------------|-------------|
| VER | DESCRIPTION | DATE |
| A0 | NEW DESIGN | Jan-22-2021 |

Top View

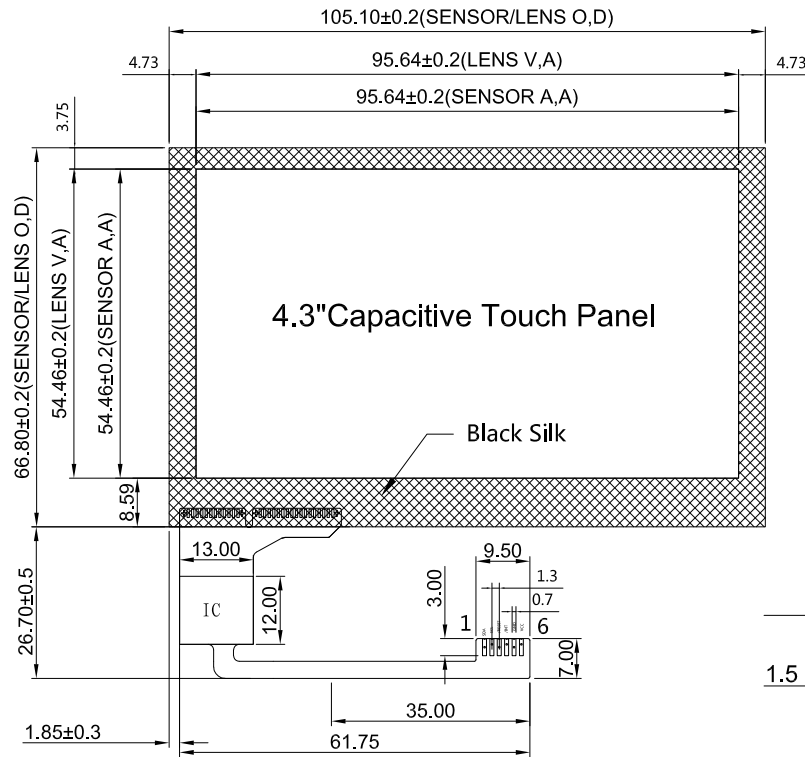

Side View

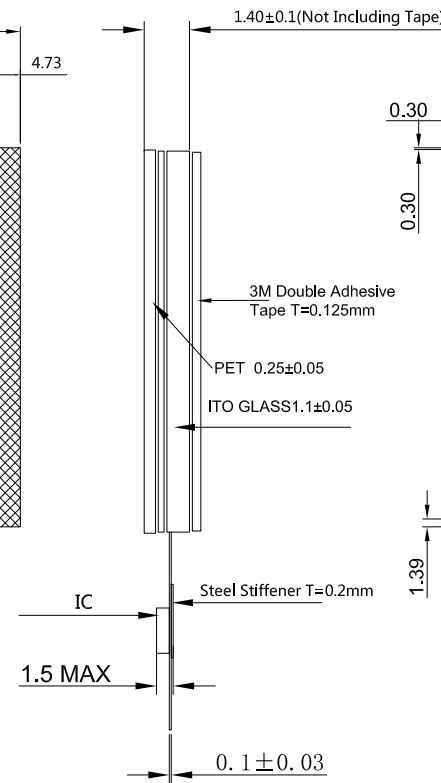

Bottom View

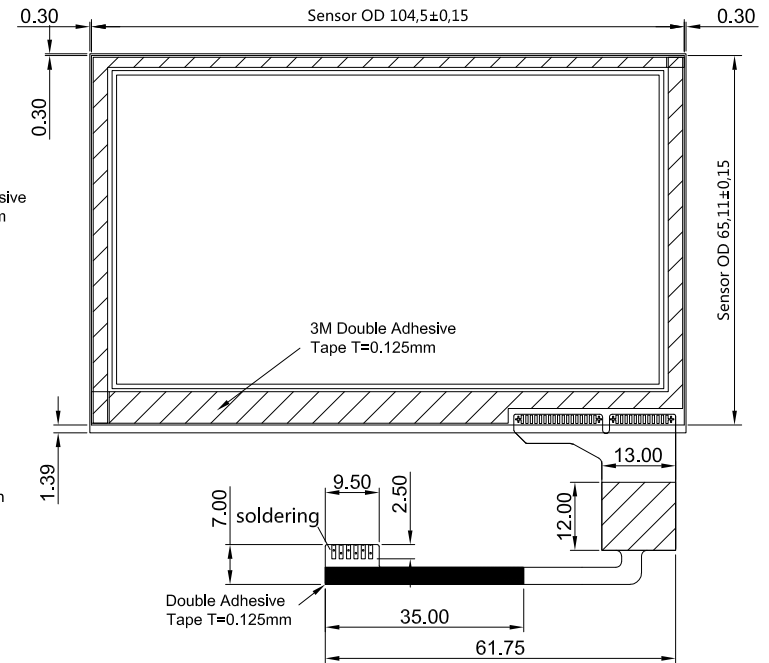

| Item | Specification |
|-------------------------|--------------------|
| 1.Type | P+G |
| 2.Operating Voltage | 1.8V~3.5V |
| 3.Operation Temperature | -20°C~70°C |
| 4.Storage Temperature | -30°C~80°C |
| 5.Connect Material | FPC |
| 6.Response Time | $\leq 25\text{ms}$ |
| 7.Light Transparency | 87% Min. |
| 8.Surface Hardness | 3H(Pencil) |

| IC | FT5206 |
|------|------------|
| PIN# | ASSIGNMENT |
| 1 | SCL |
| 2 | SDA |
| 3 | VDD |
| 4 | RESET |
| 5 | INT |
| 6 | GND |

| | | | |
|-------------------------|-----------------|---|-------------|
| | | 旭日东方科技有限公司 EASTRISING TECHNOLOGY CO.,LTD | |
| Web: www.buydisplay.com | | Email: sales@buydisplay.com | |
| APPROVALS | DATE | MODEL NUMBER : | |
| APP | | ER-TPC043A1-2 | |
| CHK | | DO NOT SCALE THIS DRAWING. | GENERAL TOL |
| DWN | JIM Jan-22-2021 | | UNITS |
| | | | MM |
| | | | SCALE: |
| | | | N.T.S. |
| | | | SHEET: |
| | | | 1 |