

ER3805-1

Standard Chinese Font Chip

DATASHEET

- Font Size: 15X16 dots
- Character Set: GB2312
- ASCII: 6 sets
- Data Arrangement: Vertical byte, horizontal string
- Bus Interface: SPI
- Package: SOT23-6

VER 3.5

2010-Q3

INDEX

SECTION 1: Hardware

1 General	3
1.1 Chip Feature	3
1.2 Chip Content.....	3
2 Pin Description and Interface Connection	5
2.1 Pin Configuration	5
2.2 Pin Description	5
2.3 SPI Connection Block Diagram.....	6
3 Operating Instruction.....	7
3.1 Instruction Parameter.....	7
3.2 Read Data Bytes	7
3.3 Read Data Bytes at Higher Speed.....	8
4 Electrical Characteristic	9
4.1 Absolute Maximum Rating.....	9
4.2 DC Characteristic	9
4.3 AC Characteristic.....	9
5 Package Size	11

SECTION 2: Software

6 Font Read Method	12
6.1 Character Dot Matrix Arrangement(Data Arrangement Format)	12
6.2 Dot Matrix Font Address Table.....	15
6.3 Calculation of Character Address	16
7 Appendix.....	19
7.1 GB2312 – section 1 (376 character)	19
7.2 8×16 dots national standard expand character (126 characters)	20

1 General

ER3805-1 font chip contains font size of 15X16 dots, it supports GB2312 simplify Chinese character set (Licensed by NITS) and ASCII characters. The data arrangement format is vertical byte, horizontal string. The user may obtain the address of certain character dot matrix with the calculation method given by this datasheet, which enables the user to access to more character data by continually reading from the address already obtained.

1.1 Chip Feature

- Bus Interface: SPI
- Data Arrangement: Vertical byte, horizontal string
- Frequency: 30MHz(max.) @3.3V
- Operating Voltage: 2.2V~3.6V
- Current:
 - Operating: 8mA
 - Standby: 8uA
- Package: SOT23-6
- Package Size: 2.9mmX1.6 mm x1.10mm
- Operating Temperature: -20℃~85℃

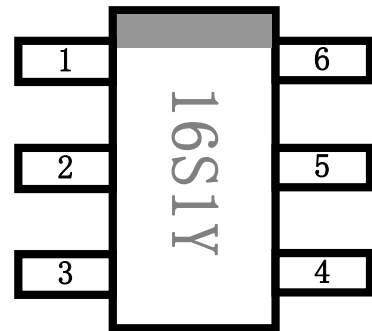

1.2 Chip Content

Type	Font Content	Character Set	Character
Chinese Font	15X16 dots GB2312 font	GB2312	6763+376
	8X16 dots national standard expand character	GB2312	126
ASCII Font	5X7 dots ASCII font	ASCII	96
	7X8 dots ASCII font	ASCII	96
	8X16 dots ASCII font	ASCII	96
	8X16 dots bold ASCII font	ASCII	96
	16 dot matrix Arial font	ASCII	96
	16 dot matrix Times New Roman font	ASCII	96

Font Sample

15X16 dots GB2312

啊阿埃挨哎唉哀皑癌蔼矮艾
碍爱隘鞍氨安俺按暗岸胺案
肮昂盎凹敖熬翱袄傲奥懊澳
芭捌扒叭吧芭八疤巴拔跋靶
把耙坝霸罢爸白柏百摆佰败
拜裨斑班搬扳般颁板版扮拌

8x16 dots national standard
expand character

!"#%&'()*+,-./012345
6789:;<=>?@ABCDEFGHIJK
LMNOPQRSTUVWXYZ[\]^_`a

5x7 dots ASCII font

!"#%&'()*+,-./0123456789:
=>?@ABCDEFGHIJKLMNQRSTU
VYZ[\]^_`abcdefghijklmnopqr

7x8 dots ASCII font

!"#\$%&'()*+,-./01234
56789:;<=>?@ABCDEFGHIJ
KLMNOPQRSTUVWXYZ[\]^_`
abcdefghijklmnopqrstuv
6789:;<=>?@ABCDEFGHIJ

8x16 dots ASCII font

!"#%&'()*+,-./012345
6789:;<=>?@ABCDEFGHIJK
LMNOPQRSTUVWXYZ[\]^_`a

8x16 dots bold ASCII font

!"#\$%&'()*+,-./012345
6789:;<=>?@ABCDEFGHIJKLM
ijklmnopqrstuvwxyz{|}

16 dot matrix Arial font

!"#\$%&'()*+,-./0123456789:;<=>
DEFGHIJKLMNOPQRSTUVWXYZ
abcdefghijklmnopqrstuvwxyz{

16 dot matrix Times New
Roman font

!"#\$%&'()*+,-./0123456789
:;<=>?@ABCDEFGHIJKLM
cdefghijklmnopqrstuvwxyz{|}

2 Pin Description and Interface Connection

2.1 Pin Configuration

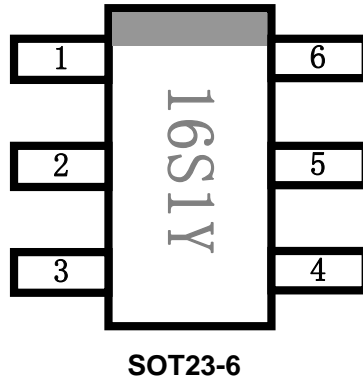

2.2 Pin Description

SOT23-6	Name	I/O	Description
1	SCLK	I	Serial clock input
2	GND		Ground
3	CS#	I	Chip enable input
4	VCC		+ 3.3V Power Supply
5	SO	O	Serial data output
6	SI	I	Serial data input

Serial Data Output (SO): Data shift-out on the falling edge of the serial clock.

Serial Data Input (SI): Data shift-in on the rising edge of the serial clock.

Serial Clock Input (SCLK): Data shift-out on the falling edge of the serial clock, shift-in on the rising edge of the serial clock.

Chip Enable Input (CS#): The device is enabled by a high to low transition on CS#. CS# must remain low for the duration of any command sequence.

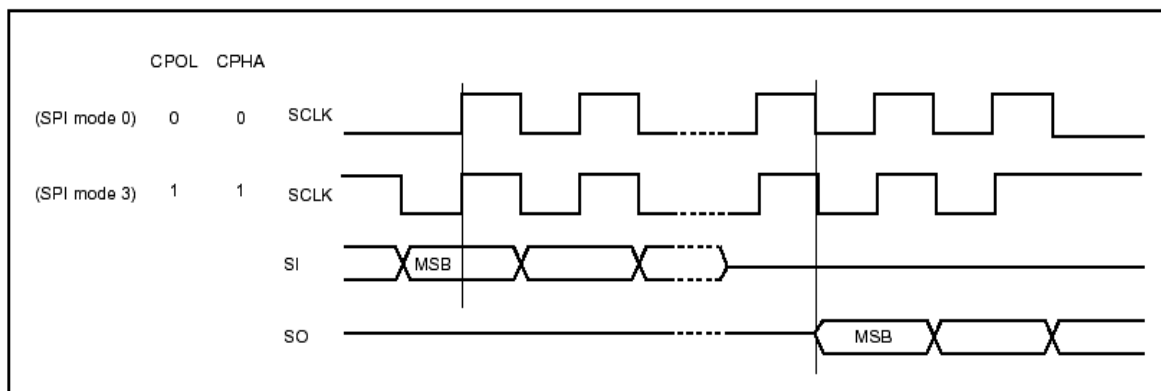

2.3 SPI Connection Block Diagram

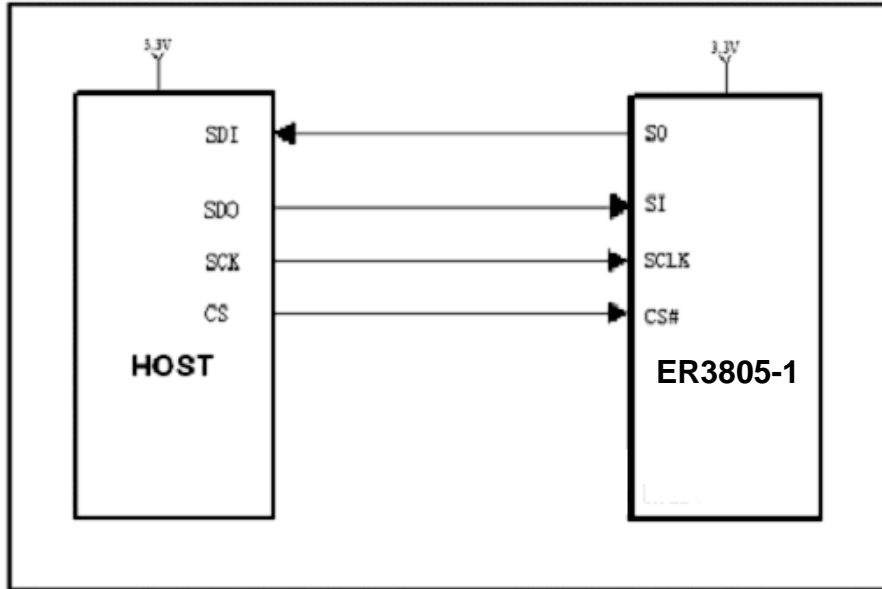

SPI Connection Block Diagram

3 Operating Instruction

3.1 Instruction Parameter

Instruction Set

Instruction	Description	Instruction Code(One-Byte)		Address Bytes	Dummy Bytes	Data Bytes
READ	Read Data Bytes	0000 0011	03 h	3	—	1 to ∞
FAST_READ	Read Data Bytes at Higher Speed	0000 1011	0B h	3	1	1 to ∞

3.2 Read Data Bytes

The Read instruction supports up to 20 MHz, It outputs the data starting from the specified address location. The data output stream is continuous through all addresses until terminated by a low to high transition on CE#. The internal address pointer will automatically increment.

The Read instruction is initiated by executing an 8-bit command,03H, followed by address bits [A23-A0]. CE# must remain active low for the duration of the Read cycle.

Figure: Read Data Bytes (READ) Instruction Sequence and Data-out sequence:

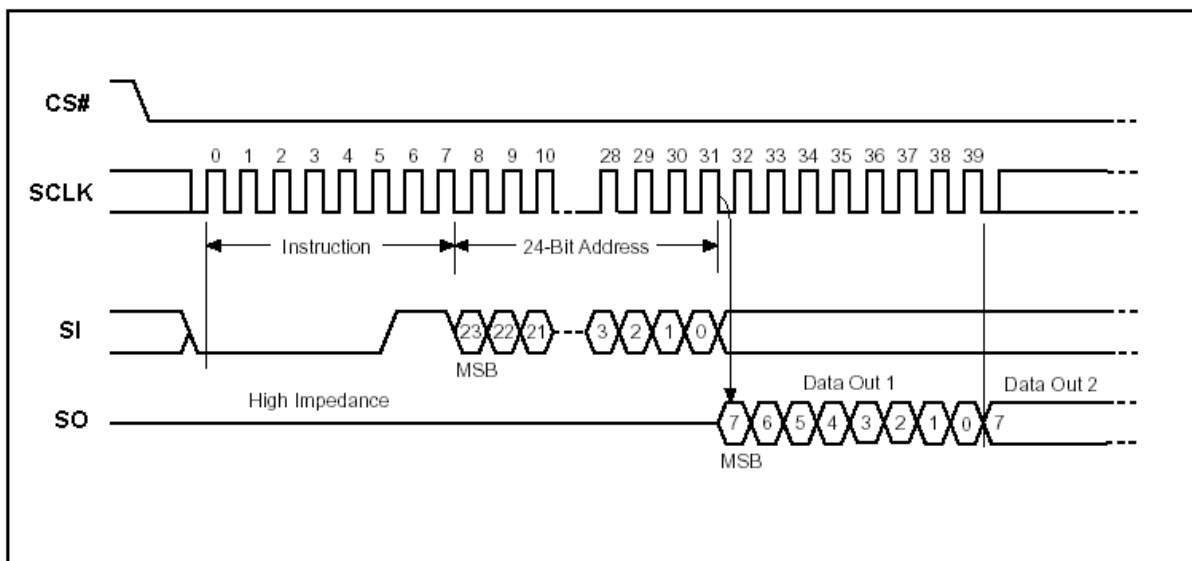

3.3 Read Data Bytes at Higher Speed

The High-Speed-Read instruction supporting up to 30 MHz is initiated by executing an 8-bit command, 0BH, followed by address bits [A23-A0] and a dummy byte. CE# must remain active low for the duration of the High-Speed-Read cycle.

Following a dummy byte (8 clocks input dummy cycle), the High-Speed-Read instruction outputs the data starting from the specified address location. The data output stream is continuous through all addresses until terminated by a low to high transition on CE#. The internal address pointer will automatically increment.

Figure: Read Data Bytes at Higher Speed (READ_FAST) Instruction Sequence and Data-out sequence:

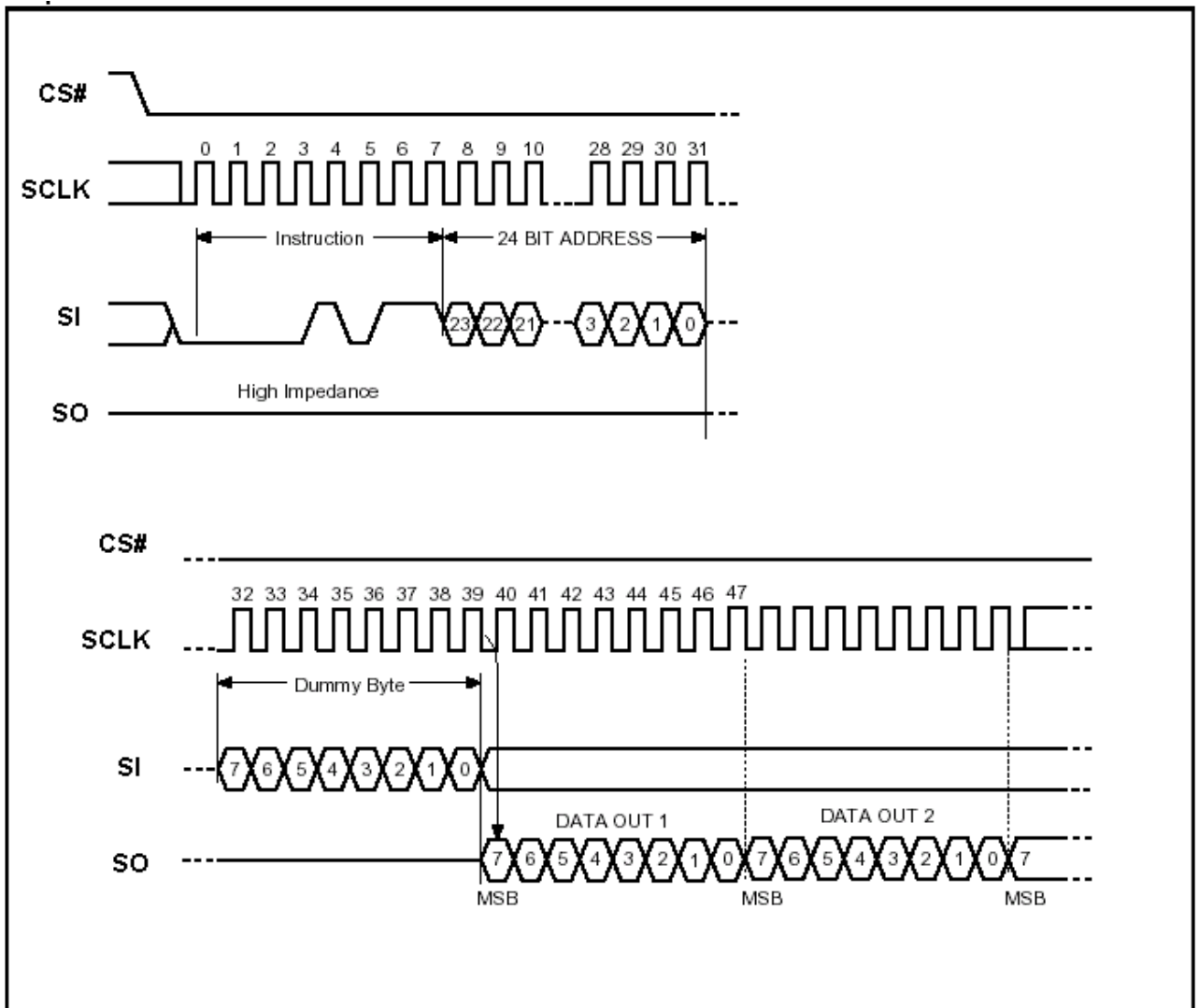

4 Electrical Characteristic

4.1 Absolute Maximum Rating

Symbol	Parameter	Min.	Max.	Unit	Condition
T _{OP}	Operating Temperature	-20	85	°C	
T _{STG}	Storage Temperature	-65	150	°C	
VCC	Supply Voltage	-0.3	3.6	V	
V _{IN}	Input Voltage	-0.3	VCC+0.3	V	
GND	Power Ground	-0.3	0.3	V	

4.2 DC Characteristic

Condition: T_{OP} = -20°C to 85°C, GND=0V

Symbol	Parameter	Min.	Max.	Unit	Condition
I _{DD}	VCC Supply Current(active)		8	mA	VCC=2.2~3.6V
I _{SB}	VCC Standby Current		8	uA	
V _{IL}	Input LOW Voltage	-0.3	0.3VCC	V	
V _{IH}	Input HIGH Voltage	0.7VCC	VCC+0.4	V	
V _{OL}	Output LOW Voltage		0.4 (I _{OL} =1.6mA)	V	
V _{OH}	Output HIGH Voltage	0.8VCC (I _{OH} =-100uA)		V	
I _{LI}	Input Leakage Current	0	2	uA	
I _{LO}	Output Leakage Current	0	2	uA	

Note: I_{IL}: Input LOW Current, I_{IH}: Input HIGH Current,
I_{OL}: Output LOW Current, I_{OH}: Output HIGH Current,

4.3 AC Characteristic

Symbol	Alt.	Parameter	Min.	Max.	Unit
Fc	Fc	Clock Frequency	D.C.	30	MHz
t _{CH}	t _{CLH}	Clock High Time	15		ns
t _{CL}	t _{CLL}	Clock Low Time	15		ns
t _{CLCH}		Clock Rise Time(peak to peak)	0.1		V/ns
t _{CHCL}		Clock Fall Time (peak to peak)	0.1		V/ns
t _{SLCH}	t _{css}	CS# Active Setup Time (relative to SCLK)	5		ns
t _{CHSL}		CS# Not Active Hold Time (relative to SCLK)	5		ns
t _{dvch}	t _{dsu}	Data In Setup Time	2		ns
t _{chdx}	t _{dh}	Data In Hold Time	5		ns
t _{chsh}		CS# Active Hold Time (relative to SCLK)	5		ns
t _{shch}		CS# Not Active Setup Time (relative to SCLK)	5		ns
t _{shsl}	t _{csH}	CS# Deselect Time	100		ns
t _{shqz}	t _{dis}	Output Disable Time		9	ns
t _{clqv}	t _v	Clock Low to Output Valid		9	ns
t _{clqx}	t _{ho}	Output Hold Time	0		ns

Serial Input Timing

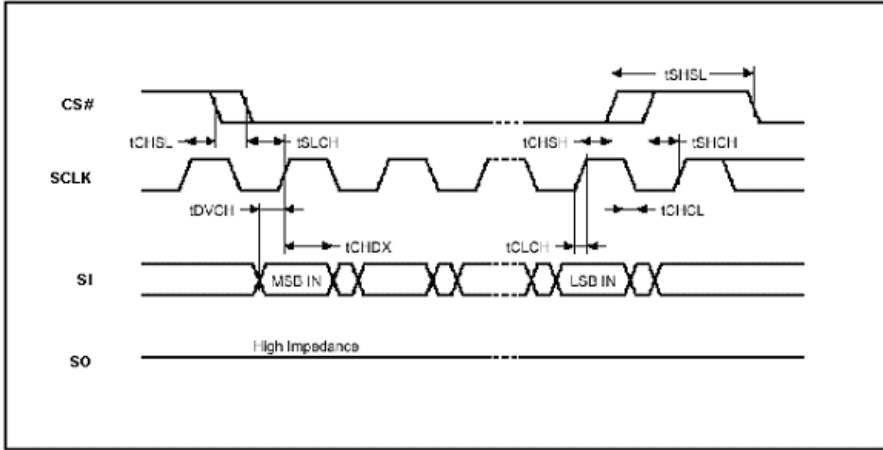

Output Timing

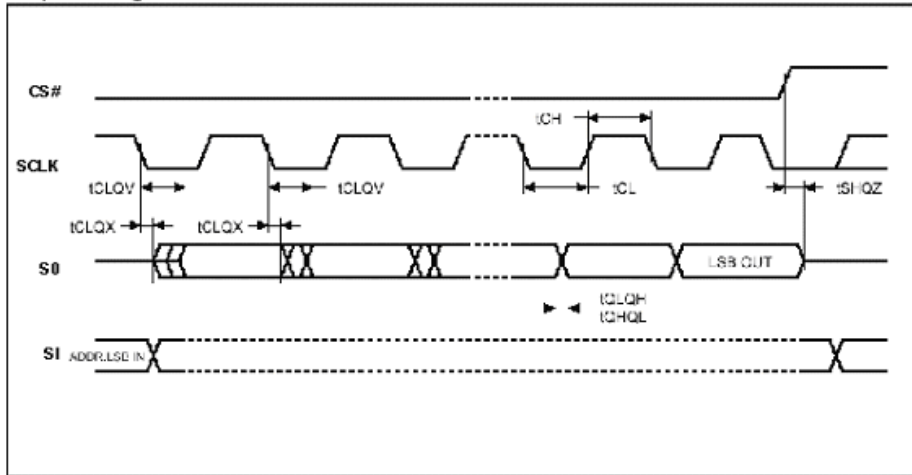

5 Package Size

SOT23-6 Package

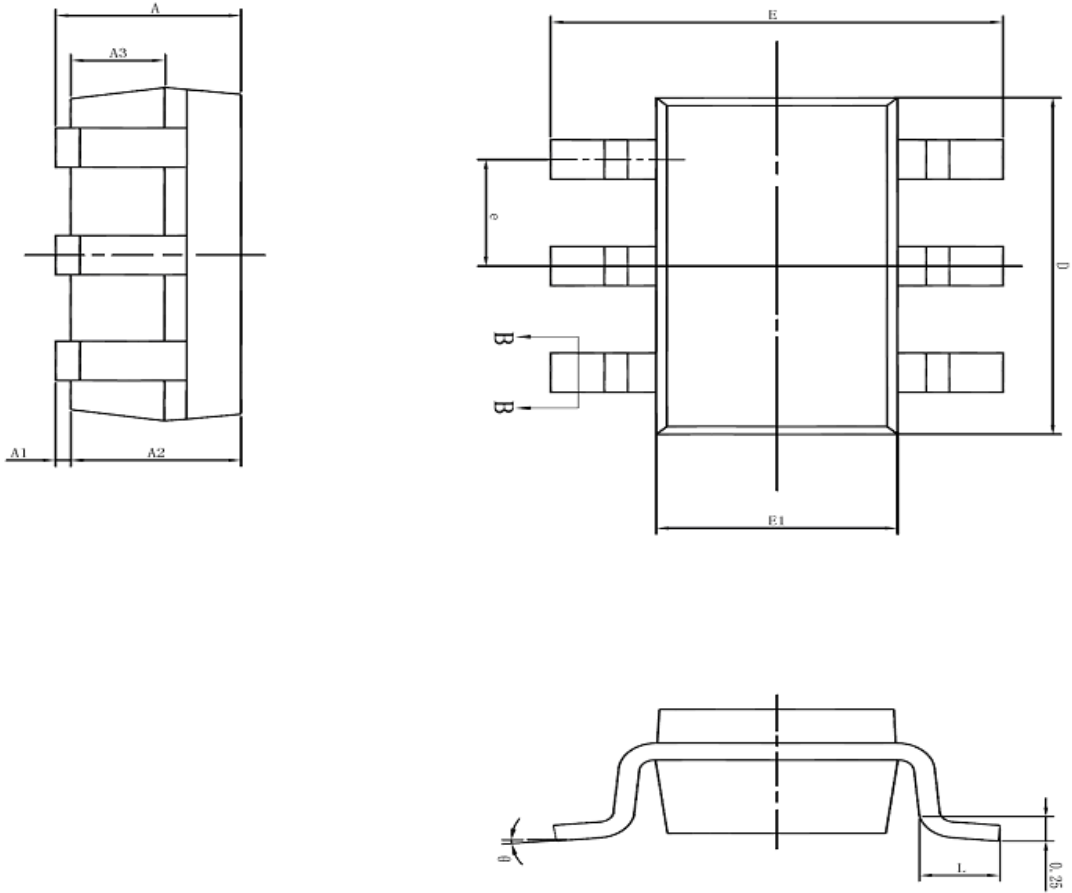

SYMBOL	MILLIMETER		
	MIN	NOM	MAX
A	—	—	1.30
A1	0.04	0.07	0.10
A2	1.00	1.10	1.20
A3	0.55	0.65	0.75
D	2.72	2.92	3.12
E	2.60	2.80	3.00
E1	1.40	1.60	1.80
e	0.95BSC		
L	0.30	—	0.60
theta	0	—	8°

SOT23-6 Package

6 Font Read Method

6.1 Character Dot Matrix Arrangement(Data Arrangement Format)

Each character is stored in the Chinese dot matrix format, each dot is expressed by a binary bit. 1 represents for lightened dot, 0 represents for unlightened dot. The data arrangement format is byte vertical, string horizontal. The biggest bit of BYTE represents the most left point, the smallest bit of BYTE represents the most right point. Advances when horizontal row is booked. Chinese will display when using the above method.

6.1.1 15X16 dots Chinese font

15X16 dots font requires 32 bytes (BYTE 0 – BYTE 31) to display. Data arrangement format of this 15X16 dots font is byte vertical, string horizontal, the detailed arrangement structure is showed below:

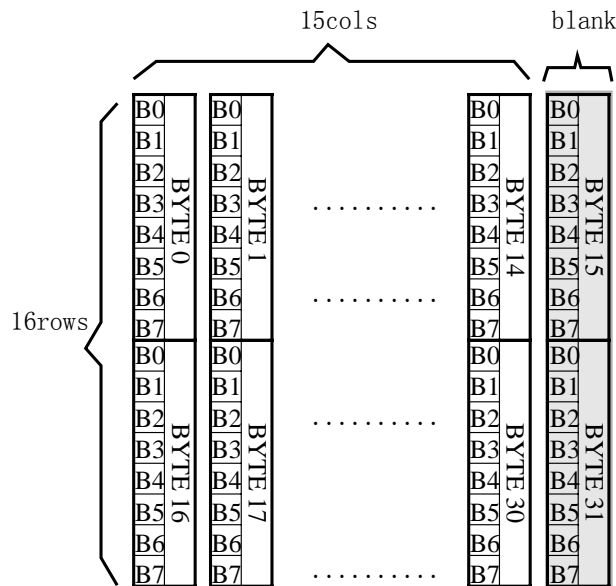

6.1.2 5X7 dots ASCII font

5X7 dots ASCII font requires 8 bytes (BYTE 0 – BYTE 7) to display. Data arrangement format of this ASCII font is byte horizontal, string horizontal, the detailed arrangement structure is showed below:

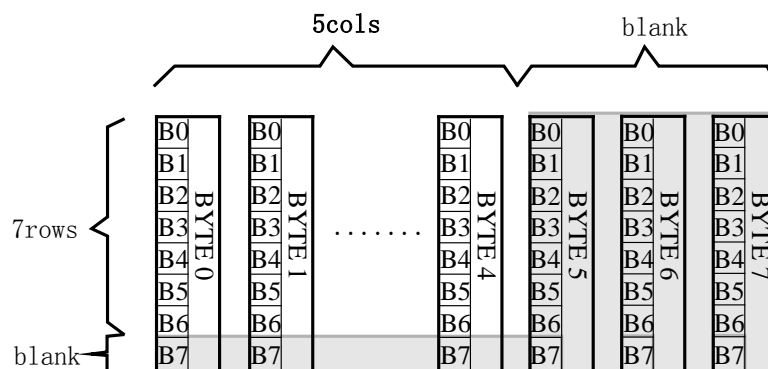

6.1.3 7X8 dots ASCII font

7X8 dots ASCII font requires 8 bytes (BYTE 0 – BYTE7) to display. Data arrangement format of this ASCII font is byte vertical, string horizontal, the detailed arrangement structure is showed below:

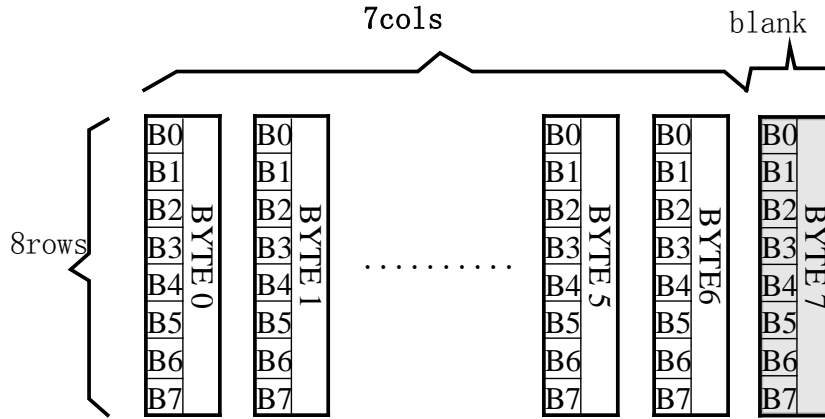

6.1.4 8X16 dots font

The following fonts can be applied to this data arrangement format:

8X16 dots ASCII font

8X16 dots bold ASCII font

8X16 dots national standard expand character

8X16 dots font requires 16 bytes (BYTE 0 – BYTE15) to display. Data arrangement format of this font is byte vertical, string horizontal, the detailed arrangement structure is showed below:

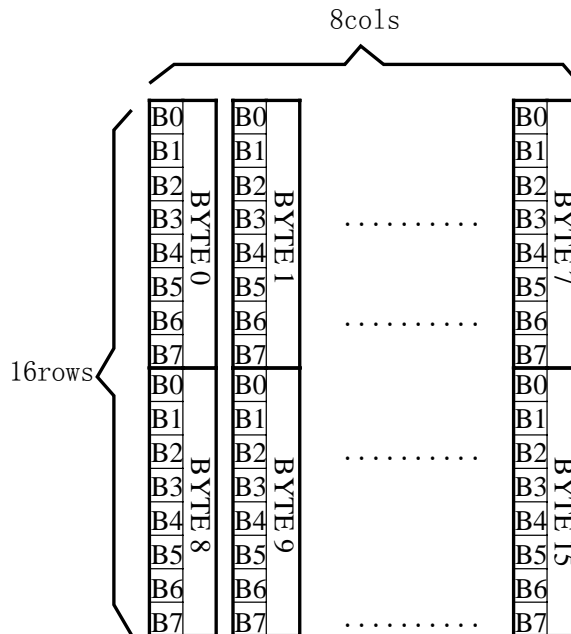

6.1.5 16 dot matrix proportional adjusted font

■ Storage Format

16 dots proportionally adjusted font requires 34 bytes (BYTE 0 – BYTE33) to display.

For the font is proportionally adjusted, BYTE0~ BYTE1 are stored font width data, BYTE2-33 are stored dots matrix data.

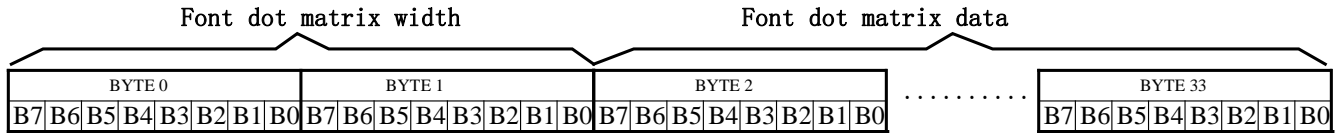

■ Storage Structure

The dots matrix storage width of proportionally adjusted font uses BYTE as its unit. Different font width will reveal corresponding blanks. With the font's actual width data stored in BYTE0~BYTE 1, it can be used as reference for the position of the next word.

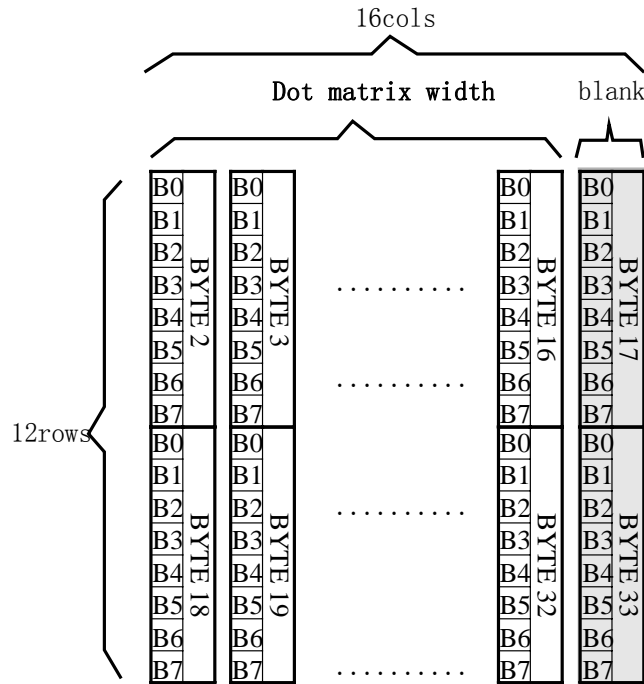

For Example: ASCII Arial Font “B”

0-33 BYTE: 00 0C 00 00 00 00 00 00 7F 80 7F C0 60 C0 60 C0 60 C0 7F 80 7F C0 60 E0 60 60 60 60 7F C0 7F 80 00 00

In BYTE0~BYTE1: “00 0C” is width data, 12 bit width, 4 blank bits is reserved. The typeset of the next word may shift forward considering the blank bits.

In BYTE2~BYTE33: “00 00 00 00 00 00 7F 80 7F C0 60 C0 60 C0 60 C0 7F 80 7F C0 60 E0 60 60 60 60 7F C0 7F 80 00 00” is dot matrix data.

6.2 Dot Matrix Font Address Table

	Content	CharSet	Code Scope	Character	Starting Address	Ending Address	Reference Method
1	15X16 dots GB2312 font	GB2312	A1A1-F7FE	6763+376	00000	3B7BF	6.3.1.1
2	7X8 dots ASCII font	ASCII	20~7F	96	66C0	69BF	6.3.2.2
3	8X16 dots national standard expand character	GB2312	AAA1-ABC0	126	3B7D0	3BFBF	6.3.1.2
4	8X16 dots ASCII font	ASCII	20~7F	96	3B7C0	3BFBF	6.3.2.3
5	5X7 dots ASCII font	ASCII	20~7F	96	3BFC0	3C2BF	6.3.2.1
6	16 dot matrix Arial font	ASCII	20~7F	96	3C2C0	3CF7F	6.3.2.4
7	8X16 dots bold ASCII font	ASCII	20~7F	96	3CF80	3D57F	6.3.2.5
8	16 dot matrix Times New Roman font	ASCII	20~7F	96	3D580	3E23F	6.3.2.6

6.3 Calculation of Character Address

With certain calculation method, the user may obtain certain character dots address using character code.

6.3.1 Chinese Font

6.3.1.1 15X16 dots GB2312 font

Parameters:

GBCode: Character code.

MSB: High byte of GB code.

LSB: Low byte of GB code.

Address: Address of character data.

BaseAdd: Base address of font.

Calculation of character address:

BaseAdd=0;

if(MSB ==0xA9 && LSB >=0xA1)

Address = (282 + (LSB - 0xA1))*32+BaseAdd;

else if(MSB >=0xA1 && MSB <= 0xA3 && LSB >=0xA1)

Address =((MSB - 0xA1) * 94 + (LSB - 0xA1))*32+ BaseAdd;

else if(MSB >=0xB0 && MSB <= 0xF7 && LSB >=0xA1)

Address = ((MSB - 0xB0) * 94 + (LSB - 0xA1)+ 846)*32+ BaseAdd;

6.3.1.2 8X16 dots national standard expand character

Parameter:

ASCIICode: ASCII character code (8bits)

BaseAdd: Base address of font.

Address: Address of ASCII character data.

Calculation of character address:

BaseAdd=0x3b7d0

if (FontCode>= 0xAAA1) and (FontCode<=0xAAFE) then

ByteAddress = (FontCode-0xAAA1) * 16+BaseAdd

Else if(FontCode>= 0xABA1) and (FontCode<=0xABC0) then

ByteAddress = (FontCode-0xABA1 + 95) * 16+BaseAdd

6.3.2 ASCII Font

6.3.2.1 5X7 dots ASCII font

Parameter:

ASCIICode: ASCII character code (8bits)

BaseAdd: Base address of font.

Address: Address of ASCII character data.

Calculation of character address:

BaseAdd=0x3bfc0

if (ASCIICode >= 0x20) and (ASCIICode <= 0x7E) then
 Address = (ASCIICode - 0x20) * 8 + BaseAdd

6.3.2.2 7X8 dots ASCII font

Parameter:

ASCIICode: ASCII character code (8bits)

BaseAdd: Base address of font.

Address: Address of ASCII character data.

Calculation of character address:

BaseAdd=0x66c0

if (ASCIICode >= 0x20) and (ASCIICode <= 0x7E) then
 Address = (ASCIICode - 0x20) * 8 + BaseAdd

6.3.2.3 8X16 dots ASCII font

Parameter:

ASCIICode: ASCII character code (8bits)

BaseAdd: Base address of font.

Address: Address of ASCII character data.

Calculation of character address:

BaseAdd=0x3b7c0

if (ASCIICode >= 0x20) and (ASCIICode <= 0x7E) then
 Address = (ASCIICode - 0x20) * 16 + BaseAdd

6.3.2.4 16 dot matrix Arial font

Parameter:

ASCIICode: ASCII character code (8bits)

BaseAdd: Base address of font.

Address: Address of ASCII character data.

Calculation of character address:

BaseAdd=0x3c2c0

if (ASCIICode >= 0x20) and (ASCIICode <= 0x7E) then
 Address = (ASCIICode - 0x20) * 34 + BaseAdd

6.3.2.5 8X16 dots bold ASCII font

Parameter:

ASCIICode: ASCII character code (8bits)

BaseAdd: Base address of font.

Address: Address of ASCII character data.

Calculation of character address:

BaseAdd=0x3cf80

if (ASCIICode >= 0x20) and (ASCIICode <= 0x7E) then
 Address = (ASCIICode - 0x20) * 16 + BaseAdd

6.3.2.6 16 dot matrix Arial font

Parameter:

ASCIICode: ASCII character code (8bits)

BaseAdd: Base address of font.

Address: Address of ASCII character data.

Calculation of character address:

BaseAdd=0x3d580

if (ASCIICode >= 0x20) and (ASCIICode <= 0x7E) then

Address = (ASCIICode - 0x20) * 34 + BaseAdd

7 Appendix

7.1 GB2312 – section 1 (376 character)

Code scope: A1A1~A9EF

GB2312 1 区

A1	0	1	2	3	4	5	6	7	8	9	A	B	C	D	E	F
A			、	。	．	－	ˇ	¨	”	々	一	～		…	‘	’
B	“	”	()	< >	《 》	「 」	『 』	【 】	【 】	【 】						
C	±	×	÷	:	∧	∨	Σ	Π	U	∩	ε	::	√	⊥	//	∠
D	∩	⊙	∫	∫	≡	≡	≈	∞	≠	≠	≠	≠	≠	≠	∞	∴
E	∴	∴	∴	∴	∴	∴	∴	∴	∴	∴	∴	∴	∴	∴	∴	∴
F	○	●	◎	◇	◆	□	■	△	▲	※	→	←	↑	↓	=	

A2	0	1	2	3	4	5	6	7	8	9	A	B	C	D	E	F
A																
B		1.	2.	3.	4.	5.	6.	7.	8.	9.	10.	11.	12.	13.	14.	15.
C	16.	17.	18.	19.	20.	(1)	(2)	(3)	(4)	(5)	(6)	(7)	(8)	(9)	(10)	(11)
D	(12)	(13)	(14)	(15)	(16)	(17)	(18)	(19)	(20)	①	②	③	④	⑤	⑥	⑦
E	⑧	⑨	⑩	€		(一)	(二)	(三)	(四)	(五)	(六)	(七)	(八)	(九)	(十)	
F		I	II	III	IV	V	VI	VII	VIII	IX	X	XI	XII			

A3	0	1	2	3	4	5	6	7	8	9	A	B	C	D	E	F
A		!	”	#	¥	%	&	'	()	*	+	,	-	.	/	
B	0	1	2	3	4	5	6	7	8	9	:	;	<	=	>	?
C	@	A	B	C	D	E	F	G	H	I	J	K	L	M	N	O
D	P	Q	R	S	T	U	V	W	X	Y	Z	[\]	^	_
E	`	a	b	c	d	e	f	g	h	i	j	k	l	m	n	o
F	p	q	r	s	t	u	v	w	x	y	z	{		}	~	

A9	0	1	2	3	4	5	6	7	8	9	A	B	C	D	E	F
A					—	—			---	---	!	!	---	---	!	!
B	┌	┌	┌	┌	┌	┌	┌	┌	┌	┌	┌	┌	┌	┌	┌	┌
C	└	└	└	└	└	└	└	└	└	└	└	└	└	└	└	└
D	┘	┘	┘	┘	┘	┘	┘	┘	┘	┘	┘	┘	┘	┘	┘	┘
E	+	+	+	+	+	+	+	+	+	+	+	+	+	+	+	+
F																

7.2 8x16 dots national standard expand character (126 characters)

Code Scope: AAA1~ABC0

AA	0	1	2	3	4	5	6	7	8	9	A	B	C	D	E	F
A		!	"	#	¥	%	&	†	()	*	+	,	-	.	/
B	0	1	2	3	4	5	6	7	8	9	:	;	<	=	>	?
C	@	A	B	C	D	E	F	G	H	I	J	K	L	M	N	O
D	P	Q	R	S	T	U	V	W	X	Y	Z	[\]	^	_
E	'	a	b	c	d	e	f	g	h	i	j	k	l	m	n	o
F	p	q	r	s	t	u	v	w	x	y	z	{		}		

AB	0	1	2	3	4	5	6	7	8	9	A	B	C	D	E	F
A		ā	á	ǎ	à	ē	é	ě	è	ī	í	ǐ	ì	ō	ó	ǒ
B	ò	ū	ú	ǔ	ù	ū	ú	ǔ	ù	ü	ê	ɑ	‡	‡	‡	‡
C	g															